

chcoze

GP-3100

User Manual



Embedded GPU Computer

14/13/12th Gen Intel® Core™ Modular GPU Computer, Supports Dual Full-length GPU Expansion

Contents

Preface	6
Revision.....	6
Copyright Notice.....	6
Acknowledgement.....	6
Disclaimer	7
Declaration of Conformity	7
Product Warranty Statement	8
Technical Support and Assistance	9
Conventions Used in this Manual.....	9
Safety Precautions	10
Package Contents	11
Ordering information.....	11
Chapter 1 Product Introductions	12
1.1 Overview	13
1.2 Hardware Specification.....	16
1.3 External Layout	20
1.3.1 Front	20
1.3.2 Top.....	21
1.4 Dimensions	21
Chapter 2 Switches & Connectors	22
2.1 Location of Switches and Connectors.....	23
2.1.1 Top View	23
2.1.2 Bottom View	23
2.2 Switches and Connectors Definition.....	24
2.3 Definition of Switches.....	25
2.4 Definition of Connectors	26
2.5 Definition of Switches and Connectors on Optional Modules	34
2.5.1 CMI-M12LAN01 Module	34
2.5.2 CMI-XM12LAN01 Module.....	34
2.5.3 CMI-2P5GLAN02 Module.....	34
2.5.4 CMI-10GXM12LAN02 Module	35
2.5.5 CMI-DIO04 Module.....	36
2.5.6 CMI-COM04 Module.....	37
2.5.7 CMI-CAN01 Module	38
2.5.8 CFM-IGN03 Module	39
2.5.9 GEB-3301 Module.....	40
2.5.10 GEB-3601 Module.....	43
Chapter 3 System Setup	47

3.1 Removing Top Cover.....	48
3.2 Installing CPU & Thermal Block	51
3.3 Installing MOSFET Heatsink Thermal Pad.....	56
3.4 Installing SO-DIMM.....	57
3.5 Installing M.2 Key B Module.....	58
3.5.1 M.2 Key B 2280 Socket	58
3.5.2 M.2 Key B 3052 Socket	59
3.6 Installing M.2 Key E Module	61
3.7 Installing M.2 Key M Module.....	62
3.8 Installing Antenna(s).....	63
3.8.1 Antenna #1 to #4	63
3.8.2 Antenna #5 to #7	65
3.9 Installing Top Cover	67
3.10 Installing SATA Hard Drives at Front Panel.....	69
3.11 Installing SIM Card.....	71
3.12 Installing Rubber Foot Pad.....	73
3.13 Installing Wall Mount	74
3.14 Installing Desktop Mount Bracket	76
3.15 Installing 19" Rack Mount	78
3.16 Connecting to Power Supply	81
3.17 Installing High Speed CMI Module	82
3.17.1 CMI-LAN01/UB1812 Module.....	82
3.17.2 CMI-M12LAN01/UB1810 Module	84
3.17.3 CMI-XM12LAN01/UB1830 Module	87
3.17.4 CMI-10GLAN02/UB1828 Module	91
3.17.5 CMI-2P5GLAN02/UB1812 Module	95
3.17.6 CMI-10GXM12LAN02/UB1837 Module.....	98
3.17.7 CMI-CAN01/UB1838 Module	102
3.18 Installing Low Speed CMI Module	104
3.18.1 CMI-DIO04/UB1818 Module	104
3.18.2 CMI-COM04/UB1803 Module	107
3.19 Installing CFM Module.....	110
3.19.1 CFM-PoE01 Module.....	110
3.19.2 CFM-PoE07 Module.....	113
3.19.3 CFM-IGN03 Module.....	116
3.20 Installing GEB-3301 Module	117
3.20.1 Installing GEB-3301 Module onto GP-3100.....	117
3.20.2 Installing GPU Card	120
3.20.3 Installing Rubber Foot Pad	128
3.20.4 Installing Wall Mount	129

3.20.5 Installing 19" Rack Mount	131
3.21 Installing GEB-3601 Module	135
3.21.1 Installing GEB-3601 Module onto GP-3100.....	135
3.21.2 Installing GPU Card	139
3.21.3 Installing Rubber Foot Pad	148
3.21.4 Installing Wall Mount	150
3.21.5 Installing 19" Rack Mount	152
Chapter 4 BIOS Setup.....	156
4.1 BIOS Introduction	157
4.2 Main Setup.....	158
4.2.1 System Date.....	158
4.2.2 System Time	158
4.3 Advanced Setup.....	159
4.3.1 CPU Configuration	159
4.3.2 Power & Performance	161
4.3.3 SATA Configuration.....	161
4.3.4 PCH-FW Configuration.....	162
4.3.5 Trusted Computing.....	163
4.3.6 ACPI Settings.....	164
4.3.7 F81966 Super IO Configuration	165
4.3.8 Hardware Monitor.....	166
4.3.9 S5 RTC Wake Settings	167
4.3.10 Serial Port Console Redirection	168
4.3.11 USB Configuration	168
4.3.12 Network Stack Configuration	169
4.3.13 CSM Configuration.....	169
4.3.14 NVMe Configuration.....	170
4.4 Chipset Setup.....	171
4.4.1 System Agent (SA) Configuration	171
4.4.2 PCH-IO Configuration	175
4.5 Security Setup.....	179
4.5.1 Administrator Password	179
4.5.2 User Password	179
4.5.3 Security Boot	179
4.6 Boot Setup	180
4.6.1 Setup Prompt Timeout [1].....	180
4.6.2 Bootup NumLock State [Off]	180
4.6.3 Quiet Boot [Disabled]	180
4.6.4 Fast Boot [Disabled].....	180
4.7 Save & Exit	181

4.7.1 Save Changes and Exit	181
4.7.2 Discard Changes and Exit.....	181
4.7.3 Save Changes and Reset	181
4.7.4 Discard Changes and Reset.....	181
4.7.5 Save Changes	181
4.7.6 Discard Changes.....	181
4.7.7 Restore Defaults	181
4.7.8 Save as User Defaults	181
4.7.9 Restore User Defaults.....	181
4.8 MEBx.....	182
Chapter 5 Product Application	185
5.1 Where to download drivers?	186
5.2 Where to find the technical documents?	186

Disclaimer

This manual is intended to be used as a practical and informative guide only and is subject to change without notice. It does not represent a commitment on the part of Cincoze. This product might include unintentional technical or typographical errors. Changes are periodically made to the information herein to correct such errors, and these changes are incorporated into new editions of the publication.

Declaration of Conformity



FCC

This equipment has been tested and found to comply with the limits for a Class A digital device, pursuant to Part 15 of the FCC Rules. These limits are designed to provide reasonable protection against harmful interference when the equipment is operated in a commercial environment. This equipment generates, uses, and can radiate radio frequency energy and, if not installed and used in accordance with the instruction manual, may cause harmful interference to radio communications. Operation of this equipment in a residential area is likely to cause harmful interference in which case the user will be required to correct the interference at his own expense.



CE

The product(s) described in this manual complies with all application European Union (CE) directives if it has a CE marking. For computer systems to remain CE compliant, only CE-compliant parts may be used. Maintaining CE compliance also requires proper cable and cabling techniques.



UL

A product that carries the "UL Listed" approval mark means that the product has been tested by UL to nationally recognized Safety Standards and has been found to be free from reasonably foreseeable risk of fire, electric shock and related hazards



E-Mark

The "E" mark is based on ECE regulations issued by the Economic Commission for Europe. It is an organizational part of the UN and the members are EU countries and many others. Therefore, the acceptance of approved components is much broader, especially in the eastern part of Europe. It is necessary to confirm whether a particular country has accepted (signed) the application of an ECE-regulation; as the application it is not mandatory for the countries.

Product Warranty Statement

Warranty

Cincoze products are warranted by Cincoze Co., Ltd. to be free from defect in materials and workmanship for 2 years from the date of purchase by the original purchaser. During the warranty period, we shall, at our option, either repair or replace any product that proves to be defective under normal operation. Defects, malfunctions, or failures of the warranted product caused by damage resulting from natural disasters (such as by lightning, flood, earthquake, etc.), environmental and atmospheric disturbances, other external forces such as power line disturbances, plugging the board in under power, or incorrect cabling, and damage caused by misuse, abuse, and unauthorized alteration or repair, and the product in question is either software, or an expendable item (such as a fuse, battery, etc.), are not warranted.

RMA

Before sending your product in, you will need to fill in the Cincoze RMA Request Form and obtain an RMA number from us. Our staff is available at any time to provide you with the most friendly and immediate service.

■ RMA Instruction

- Customers must fill in the Cincoze Return Merchandise Authorization (RMA) Request Form and obtain an RMA number prior to returning a defective product to Cincoze for service.
- Customers must collect all the information about the problems encountered and note anything abnormal, and describe the problems on the "Cincoze Service Form" for the RMA number application process.
- Charges may be incurred for certain repairs. Cincoze will charge for repairs to products whose warranty period has expired. Cincoze will also charge for repairs to products if the damage resulted from acts of God, environmental or atmospheric disturbances, or other external forces through misuse, abuse, or unauthorized alteration or repair. If charges will be incurred for a repair, Cincoze lists all charges and will wait for the customer's approval before performing the repair.
- Customers agree to ensure the product or assume the risk of loss or damage during transit, to prepay shipping charges, and to use the original shipping container or equivalent.
- Customers can be sent back the faulty products with or without accessories (manuals, cables, etc.) and any components from the system. If the components were suspected as part of the problem, please note clearly which components are included. Otherwise, Cincoze is not responsible for the devices/parts.
- Repaired items will be shipped along with a "Repair Report" detailing the findings and actions taken.

Limitation of Liability

Cincoze' liability arising out of the manufacture, sale, or supplying of the product and its use, whether based on warranty, contract, negligence, product liability, or otherwise, shall not exceed the original selling price of the product. The remedies provided herein are the customer's sole and exclusive remedies. In no event shall Cincoze be liable for direct, indirect, special or consequential damages whether based on contract of any other legal theory.

Technical Support and Assistance

1. Visit the Cincoze website at www.cincoze.com where you can find the latest information about the product.
2. Contact your distributor or our technical support team, or sales representative for technical support if you need additional assistance. Please have following information ready before you call:
 - Product name and serial number
 - Description of your peripheral attachments
 - Description of your software (operating system, version, application software, etc.)
 - A complete description of the problem
 - The exact wording of any error messages

Conventions Used in this Manual



WARNING
(AVERTIR)

This indication alerts operators to an operation that, if not strictly observed, may result in severe injury.
(Cette indication avertit les opérateurs d'une opération qui, si elle n'est pas strictement observée, peut entraîner des blessures graves.)



CAUTION
(ATTENTION)

This indication alerts operators to an operation that, if not strictly observed, may result in safety hazards to personnel or damage to equipment.
(Cette indication avertit les opérateurs d'une opération qui, si elle n'est pas strictement observée, peut entraîner des risques pour la sécurité du personnel ou des dommages à l'équipement.)



NOTE
(NOTE)

This indication provides additional information to complete a task easily.
(Cette indication fournit des informations supplémentaires pour effectuer facilement une tâche.)

Safety Precautions

Before installing and using this device, please note the following precautions.

1. Read these safety instructions carefully.
2. Keep this User's Manual for future reference.
3. Disconnect this equipment from any AC outlet before cleaning.
4. For plug-in equipment, the power outlet socket must be located near the equipment and must be easily accessible.
5. Keep this equipment away from humidity.
6. Put this equipment on a reliable surface during installation. Dropping it or letting it fall may cause damage.
7. Make sure the voltage of the power source is correct before connecting the equipment to the power outlet.
8. Use a power cord that has been approved for use with the product and that matches the voltage and current marked on the product's electrical range label. The voltage and current rating of the cord must be greater than the voltage and current rating marked on the product.
9. Position the power cord so that people cannot step on it. Do not place anything over the power cord.
10. All cautions and warnings on the equipment should be noted.
11. If the equipment is not used for a long time, disconnect it from the power source to avoid damage by transient overvoltage.
12. Never pour any liquid into an opening. This may cause fire or electrical shock.
13. Never open the equipment. For safety reasons, the equipment should be opened only by qualified service personnel.

If one of the following situations arises, get the equipment checked by service personnel:

- The power cord or plug is damaged.
 - Liquid has penetrated into the equipment.
 - The equipment has been exposed to moisture.
 - The equipment does not work well, or you cannot get it to work according to the user's manual.
 - The equipment has been dropped and damaged.
 - The equipment has obvious signs of breakage.
14. CAUTION: Danger of explosion if battery is incorrectly replaced. Replace only with the same or equivalent type recommended by the manufacturer.
 15. Equipment intended only for use in a RESTRICTED ACCESS AREA.
 16. Output of the external power source shall comply with ES1, PS3 requirements, output rating between 9-48 VDC, minimum 11.5-2.5 A, with minimum rated maximum ambient temperature 70°C, and has to

be evaluated according to UL/IEC/EN 60950-1 and/or UL/IEC/EN 62368-1. Please contact Cincoze for more information.

17. Ensure to connect the power cord of the power adapter to a socket-outlet with an earth connection.
18. Dispose of used battery promptly. Keep away from children. Do not disassemble and do not dispose of in fire.

Package Contents

Before installation, please ensure all the items listed in the following table are included in the package.

Item	Description	Q'ty
1	GP-3100 GPU Computer	1
2	Desktop Mount Kit	1
3	CPU Heatsink and Thermal Pad Kit	1
4	Screw Pack	4
5	M.2 Key B Type 3052 to 3042 Adapter Bracket	1
6	Wall Mount Bracket	1
7	Rubber Foot Kit	1
8	Power Terminal Block Connector	2
9	Remote Function Terminal Block Connector	2

Note: Notify your sales representative if any of the above items are missing or damaged.

Ordering information

Before installation, please ensure all the items listed in the following table are included in the package. Notify your sales representative if any of the above items are missing or damaged.

GP-3100

Available Models

Model No.	Product Description
GP-3100	14/13/12th Gen Intel® Core™ Modular GPU Computer, Supports Dual Full-length GPU Expansion



Chapter 1

Product Introductions

1.1 Overview

The GP-3100 is a high-performance GPU computer for industrial AI and machine vision applications. It supports an Intel® Core™ processor, up to two 300W full-length GPU cards (@48 VDC), high-capacity storage, and high-speed I/O. Three patented features, designed for specific customer needs, improve expansion, heat dissipation, and overall stability, making the GP-3100 an ideal choice for complex Edge AI applications.

Key Features

- 14/13/12th Gen. Core™ i9/i7/i5/i3 Processors (max 65 W TDP)
- 2 x DDR5 SO-DIMM Sockets, Supports ECC/non ECC type Memory, Up to 5600MHZ, 96GB
- 4 x 2.5GbE LAN and optional 2x 10GbE LAN
- 1x M.2 Key E Type 2230 Socket For Wireless/Bluetooth/Storage/Intel CNVi Module Expansion
- 1x M.2 Key B Type 3052/3042 Socket For 5G/GNSS/ Storage/Add-on card Expansion
- 1x M.2 Key B Type 2280 Socket For GNSS/Add-on card Expansion
- 1x M.2 Key M Type 2280 Socket For Storage/Add-on Card Expansion
- 4x 2.5" Hot Swappable SATA III HDD/SSD Bays (Max Height 15 mm)
- Optional CMI & CFM Modules for I/O Expansion & Power Ignition Sensing Function
- Versatile Mounting Methods (Tower Stand / Desktop / 19" Rack / Flat / Wall Mount)
- Wide Operating Temperature -40°C to 70°C (-40°F to 158°F)

Certification



Ultimate CPU + GPU performance

Equipped with a 14th generation Intel® Core™ (Raptor Lake-S Refresh) processor, the GP-3100 is capable of three times the computing performance of its predecessor. The GP-3100 supports up to two 300W high-end GPU cards (@48 VDC) and 5600MHz DDR5 memory with ECC for a complete AI computing solution.

14th Intel® Raptor Lake-S Refresh



Scalable and upgradeable

GPU expansion box

The dual-patented GPU expansion box (GEB) supports up to two 328mm high-end full-length GPU cards and includes multiple built-in PCIe slots for flexible use with high-speed I/O or frame grabber cards. The patented adjustable 3D GPU Card Mounting Bracket is designed for high-vibration environments and can firmly lock all GPU cards. For flexible future upgrades, the GEB can be replaced to add a higher-end GPU card or an expansion card.

Patent No.: I779496, I763318

Comprehensive cooling design

To solve the power consumption and thermal challenges, the GP-3100's mechanical structure and isolated external smart fan kits on both sides of the chassis effectively dissipate heat under full workloads in extreme conditions.

Patent No.: I778522



Rich modular design and expandability

AI applications need high-speed transmission and high-capacity storage, so the GP-3100 has 4x 2.5GbE LAN, 6x USB 3.2, 4x front-accessible 2.5" HDD/SSD, and NVMe SSD. Rich scalability capabilities include exclusive modular technology (CMI and CFM) and an M.2 slot that supports CAN bus and other modules to meet various application needs.



International standards and certifications

Rugged design passes or complies with multiple industrial standards and certifications, including MIL-STD-810H US military shock resistance, E-mark, and EN 50155 (EN 50121-3-2 only), to ensure high reliability in various application environments.



MIL-STD-810H



EN 50121-3-2



-40 – 70°C
-40 – 158°F



1.2 Hardware Specification

Model Name	GP-3100
System	
Processor	<ul style="list-style-type: none"> 14th Generation Intel® Raptor Lake-S Refresh Series CPU: <ul style="list-style-type: none"> - Intel® Core™ i9-14900 24 Cores Up to 5.8 GHz, TDP 65W - Intel® Core™ i7-14700 20 Cores Up to 5.4 GHz, TDP 65W - Intel® Core™ i5-14500 14 Cores Up to 5.0 GHz, TDP 65W - Intel® Core™ i5-14400 10 Cores Up to 4.7 GHz, TDP 65W - Intel® Core™ i3-14100 4 Cores Up to 4.7 GHz, TDP 60W - Intel® Core™ i9-14901E 8 Cores Up to 5.6 GHz, TDP 65W - Intel® Core™ i7-14701E 8 Cores Up to 5.4 GHz, TDP 65W - Intel® Core™ i5-14501E 6 Cores Up to 5.2 GHz, TDP 65W - Intel® Core™ i5-14401E 6 Cores Up to 4.7 GHz, TDP 65W - Intel® Core™ i9-14900T 24 Cores Up to 5.5 GHz, TDP 35W - Intel® Core™ i7-14700T 20 Cores Up to 5.2 GHz, TDP 35W - Intel® Core™ i5-14500T 14 Cores Up to 4.8 GHz, TDP 35W - Intel® Core™ i5-14400T 10 Cores Up to 4.5 GHz, TDP 35W - Intel® Core™ i3-14100T 4 Cores Up to 4.4 GHz, TDP 35W - Intel® Core™ i9-14901TE 8 Cores Up to 5.5 GHz, TDP 45W - Intel® Core™ i7-14701TE 8 Cores Up to 5.2 GHz, TDP 45W - Intel® Core™ i5-14501TE 6 Cores Up to 5.1 GHz, TDP 45W - Intel® Core™ i5-14401TE 6 Cores Up to 4.5 GHz, TDP 45W - Intel® Processor 300 2 Cores Up to 3.9 GHz, TDP 46W - Intel® Processor 300T 2 Cores Up to 3.4 GHz, TDP 35W 13th Generation Intel® Raptor Lake-S Series CPU: <ul style="list-style-type: none"> - Intel® Core™ i9-13900E 24 Cores Up to 5.2 GHz, TDP 65W - Intel® Core™ i7-13700E 16 Cores Up to 5.1 GHz, TDP 65W - Intel® Core™ i5-13500E 14 Cores Up to 4.6 GHz, TDP 65W - Intel® Core™ i5-13400E 10 Cores Up to 4.6 GHz, TDP 65W - Intel® Core™ i3-13100E 4 Cores Up to 4.4 GHz, TDP 65W - Intel® Core™ i9-13900TE 24 Cores Up to 5.0 GHz, TDP 35W - Intel® Core™ i7-13700TE 16 Cores Up to 4.8 GHz, TDP 35W - Intel® Core™ i5-13500TE 14 Cores Up to 4.5 GHz, TDP 35W - Intel® Core™ i3-13100TE 4 Cores Up to 4.1 GHz, TDP 35W 12th Generation Intel® Alder Lake-S Series CPU: <ul style="list-style-type: none"> - Intel® Core™ i9-12900E 16 Cores Up to 5 GHz, TDP 65W - Intel® Core™ i7-12700E 12 Cores Up to 4.8 GHz, TDP 65W - Intel® Core™ i5-12500E 6 Cores Up to 4.5 GHz, TDP 65W - Intel® Core™ i3-12100E 4 Cores Up to 4.2 GHz, TDP 60W - Intel® Core™ i9-12900TE 16 Cores Up to 4.8 GHz, TDP 35W - Intel® Core™ i7-12700TE 12 Cores Up to 4.7 GHz, TDP 35W - Intel® Core™ i5-12500TE 6 Cores Up to 4.3 GHz, TDP 35W - Intel® Core™ i3-12100TE 4 Cores Up to 4.0 GHz, TDP 35W - Intel® Pentium® G7400E 2 Cores Up to 3.6 GHz, TDP 46W - Intel® Pentium® G7400TE 2 Cores Up to 3.0 GHz, TDP 35W - Intel® Celeron® G6900E 2 Cores Up to 3.0 GHz, TDP 46W - Intel® Celeron® G6900TE 2 Cores Up to 2.4 GHz, TDP 35W
Chipset	<ul style="list-style-type: none"> Intel R680E Chipset
Memory	<ul style="list-style-type: none"> 2x DDR5 SO-DIMM sockets, support Un-buffered and ECC Type memory, up to 96GB. <ul style="list-style-type: none"> - Core™ i9/i7: Support 5600/4800 MHz with Single Rank memory and 5200/4800 MHz with Dual Rank memory. - Core™ i5/i3/Pentium®/Celeron®/Intel® Processor: Support 4800 MHz.
BIOS	<ul style="list-style-type: none"> AMI BIOS

Graphics	
Graphics Engine	<ul style="list-style-type: none"> • Integrated Intel® UHD Graphics 770: Core™ i9/i7/i5 • Integrated Intel® UHD Graphics 730: Core™ i3 • Integrated Intel® UHD Graphics 710: Pentium®/Celeron®
Maximum Display Output	<ul style="list-style-type: none"> • Supports Triple Independent Display
HDMI	<ul style="list-style-type: none"> • 1x HDMI Connector (3840 x 2160@30Hz) * Verified maximum resolution: 3840x2160@30Hz
DP	<ul style="list-style-type: none"> • 1x DisplayPort Connector (4096 x 2304@60Hz) * Verified maximum DP resolution: 3840x2160@60Hz
VGA	<ul style="list-style-type: none"> • 1x VGA Connector (1920 x 1200@60Hz)
Audio	
Audio Codec	<ul style="list-style-type: none"> • Realtek® ALC888, High Definition Audio
Line-out	<ul style="list-style-type: none"> • 1x Line-out, Phone Jack 3.5mm
Mic-in	<ul style="list-style-type: none"> • 1x Mic-in, Phone Jack 3.5mm
I/O	
LAN	<ul style="list-style-type: none"> • 4x 2.5GbE LAN, RJ45 (Intel I225) • 1x 1GbE LAN, RJ45 (Intel I219)
COM	<ul style="list-style-type: none"> • 4x RS-232/422/485 with Auto Flow Control (Supports 5V/12V), DB9
USB	<ul style="list-style-type: none"> • 6x USB 3.2 Gen1x1 (5Gbps), Type A
Storage/ Expansion	
2.5" SSD/HDD	<ul style="list-style-type: none"> • 4x 2.5" Front Accessible SATA HDD/SSD Bay Supporting HotSwap Function (SATA 3.0) (Up to 15mm in Height)
M.2 M Key Socket	<ul style="list-style-type: none"> • 1x M.2 Key M Type 2280 Socket (PCIe Gen 4x4 / SATA), Support Storage/Add-on Card Expansion
M.2 E Key Socket	<ul style="list-style-type: none"> • 1x M.2 Key E Type 2230 Socket (PCIe Gen 3x2 / USB2.0), Support Wireless/Bluetooth/Storage/ Intel CNVi Module Expansion
M.2 B Key Socket	<ul style="list-style-type: none"> • 1x M.2 Key B Type 3052/3042 Socket (PCIe Gen 3x2 / USB3.2 Gen 2x1 / SATA), Support 5G/GNSS/ Storage/Add-on card Expansion • 1x M.2 Key B Type 2280 Socket (PCIe Gen 3x1 / USB2.0), Support GNSS/Add-on card Expansion
PCIe	<ul style="list-style-type: none"> • Optional GPU Expansion Box <ul style="list-style-type: none"> - 1 x PCIe x 16 Slot (PCIe x 16 Signal) for GPU Card + 1 x PCIe x 4 Slot (Max. 25W) - 2 x PCIe x 16 Slot (PCIe x 8 Signal) for GPU Card + 1 x PCIe x 4 Slot (Max. 25W) + 1 x PCIe x 1 Slot (Max. 25W) * Single-GPU configuration: 300W @ 24VDC * Dual-GPU configuration: 500W @ 24VDC or 600W @ 48 VDC (each GPU ≤ 300 W)
CMI (Combined Multiple I/O) Interface	<ul style="list-style-type: none"> • 1 x High Speed CMI Interface for optional CMI Module Expansion • 1 x Low Speed CMI Interface for optional CMI Module Expansion
CFM (Control Function Module) Interface	<ul style="list-style-type: none"> • 1x CFM IGN Interface for optional CFM-IGN Module Expansion • 1x CFM PoE Interface for optional CFM-PoE Module Expansion
Other Function	
RAID	<ul style="list-style-type: none"> • Support RAID 0/1/5/10
FAN	<ul style="list-style-type: none"> • 2x Fan Kits (Air-flow isolated from the electronics)
Power Ignition Sensing	<ul style="list-style-type: none"> • Support Power Ignition Sensing Function with Delay Time Management and Selectable 12V/24V (With Optional CFM Module)
Clear CMOS Switch	<ul style="list-style-type: none"> • 1x Clear CMOS Switch
Reset Button	<ul style="list-style-type: none"> • 1x Reset Button
Instant Reboot	<ul style="list-style-type: none"> • Support 0.2sec Instant Reboot Technology
Watchdog Timer	<ul style="list-style-type: none"> • Software Programmable Supports 256 Levels System Reset
Antenna Holes	<ul style="list-style-type: none"> • 7x Antenna Holes

Power Requirement	
Power Button	<ul style="list-style-type: none"> • 1x ATX Power On/Off Button
Power Input Voltage	<ul style="list-style-type: none"> • 9-48VDC, Single Power Input
Connector	<ul style="list-style-type: none"> • 2x 3-pin Terminal Block, Each Terminal Block Current Limitation is 15A - Dual power connect must be used at the same time due to 15A current limitation at each power connector
Power Mode Switch	<ul style="list-style-type: none"> • 1x AT/ATX Mode Switch
Remote Power On/Off	<ul style="list-style-type: none"> • 1x Remote Power On/O, 2-pin Terminal Block
Remote Power LED	<ul style="list-style-type: none"> • 1x Remote Power LED, 2-pin Terminal Block
Max. Power Consumption	<ul style="list-style-type: none"> • 35W CPU: 201.05W • 65W CPU: 306.48W - Test conducted with CPU, 1x RAM, and 1x storage - 100% load during burn-in testing.
Inrush Current (Peak)	<ul style="list-style-type: none"> • 35W CPU: 9.221 A@24V • 65W CPU: 8.976 A@24V
Physical	
Dimension (W x D x H)	<ul style="list-style-type: none"> • 105 x 195 x 370 mm
Weight Information	<ul style="list-style-type: none"> • 7.7 KG
Mechanical Construction	<ul style="list-style-type: none"> • Extruded Aluminum with Heavy Duty Metal
Mounting	<ul style="list-style-type: none"> • Tower Stand / Desktop / 19" Rack / Flat / Wall Mount
Physical Design	<ul style="list-style-type: none"> • Jumper-less Design • Unibody Design
Reliability & Protection	
Reverse Power Input Protection	<ul style="list-style-type: none"> • Yes
Over Voltage Protection	<ul style="list-style-type: none"> • Protection Range: 51-58V • Protection Type: shut down operating voltage, re-power on at the present level to recover
Over Current Protection	<ul style="list-style-type: none"> • 30A
CMOS Battery Backup	<ul style="list-style-type: none"> • SuperCap Integrated for CMOS Battery Maintenance-free Operation
MTBF	<ul style="list-style-type: none"> • 432,065 Hours - Database: Telcordia SR-332 Issue3, Method 1, Case 3
Operating System	
Windows	<ul style="list-style-type: none"> • Windows®11, Windows®10
Linux	<ul style="list-style-type: none"> • Ubuntu Desktop 22.04 LTS
Environment	
Operating Temperature	<ul style="list-style-type: none"> • 35W TDP Processor: -40°C to 70°C (-40°F to 158°F) • 45W TPD Processor: -40°C to 60°C (-40°F to 140°F) • 65W TDP Processor: -40°C to 60°C (-40°F to 140°F) * PassMark BurnInTest: 100% CPU, 2D/3D Graphics (without thermal throttling) * With extended temperature peripherals; Ambient with air flow * According to IEC60068-2-1, IEC60068-2-2, IEC60068-2-14
Storage Temperature	<ul style="list-style-type: none"> • -40°C to 70°C
Relative Humidity	<ul style="list-style-type: none"> • 95%RH @ 70°C (non-Condensing)
Shock	<ul style="list-style-type: none"> • MIL-STD-810H
Vibration	<ul style="list-style-type: none"> • MIL-STD-810H

EMC	<ul style="list-style-type: none"> • CE, UKCA, FCC, ICES-003 Class A • EN 50155 (EN 50121-3-2 Only) • E-mark
EMI	<ul style="list-style-type: none"> • CISPR 32 Conducted & Radiated: Class A • EN/BS EN 50121-3-2 Conducted & Radiated: Class A • EN/BS EN IEC 61000-3-2 Harmonic current emissions: Class A • EN/BS EN 61000-3-3 Voltage fluctuations & flicker • FCC 47 CFR Part 15B, ICES-003 Conducted & Radiated: Class A
EMS	<ul style="list-style-type: none"> • EN/IEC 61000-4-2 ESD: Contact: 6 kV; Air: 8 kV • EN/IEC 61000-4-3 RS: 80 MHz to 1000 MHz: 20 V/m • EN/IEC 61000-4-4 EFT: AC Power: 2 kV; Signal: 2 kV • EN/IEC 61000-4-5 Surges: AC Power: 2 kV • EN/IEC 61000-4-6 CS: 10V • EN/IEC 61000-4-8 PFMF: 50 Hz, 1A/m • EN/IEC 61000-4-11 Voltage Dips & Voltage Interruptions: 0.5 cycles at 50 Hz
Fire Protection	<ul style="list-style-type: none"> • EN 45545-2
Safety	<ul style="list-style-type: none"> • UL, cUL , CB, IEC, EN 62368-1

** Product Specifications and features are for reference only and are subject to change without prior notice.*

For more information, please refer to the latest product datasheet from Cincoze's website.

1.3 External Layout

1.3.1 Front

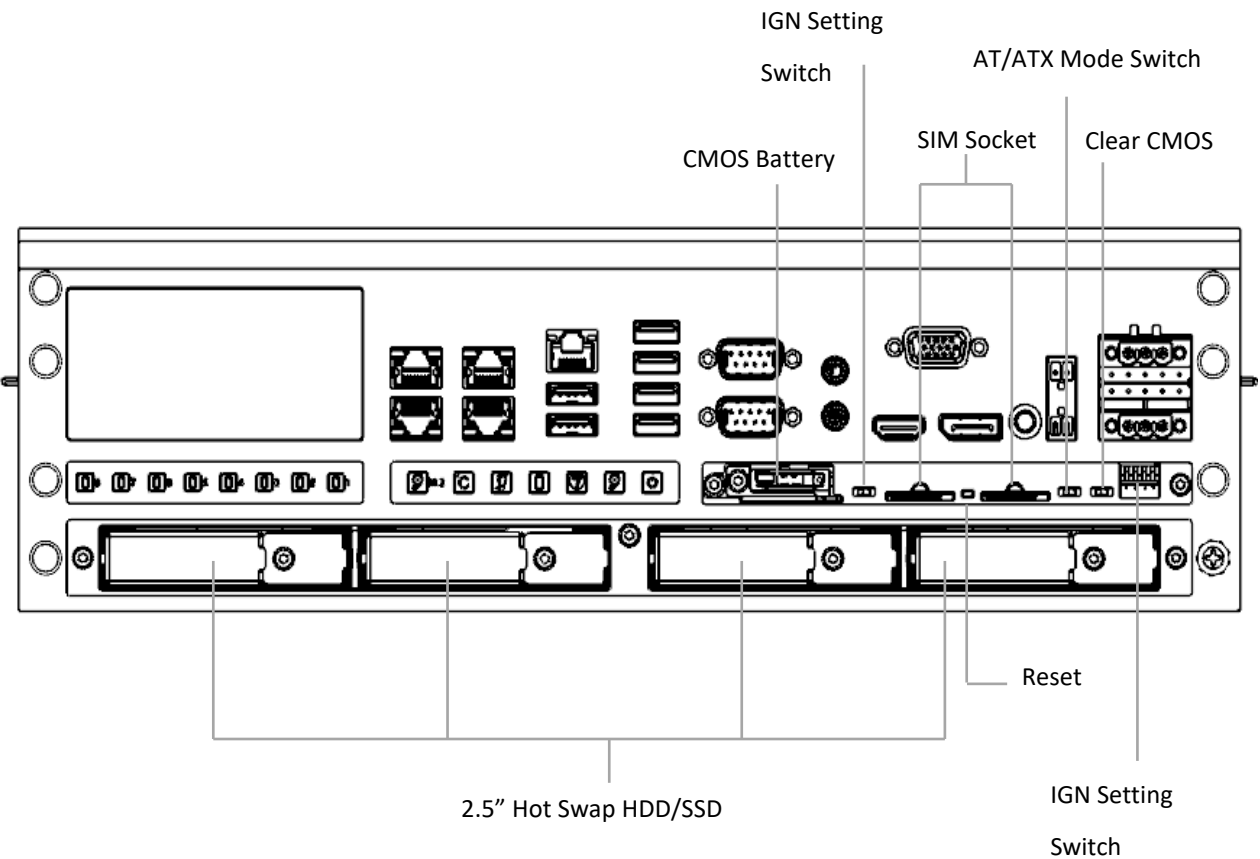
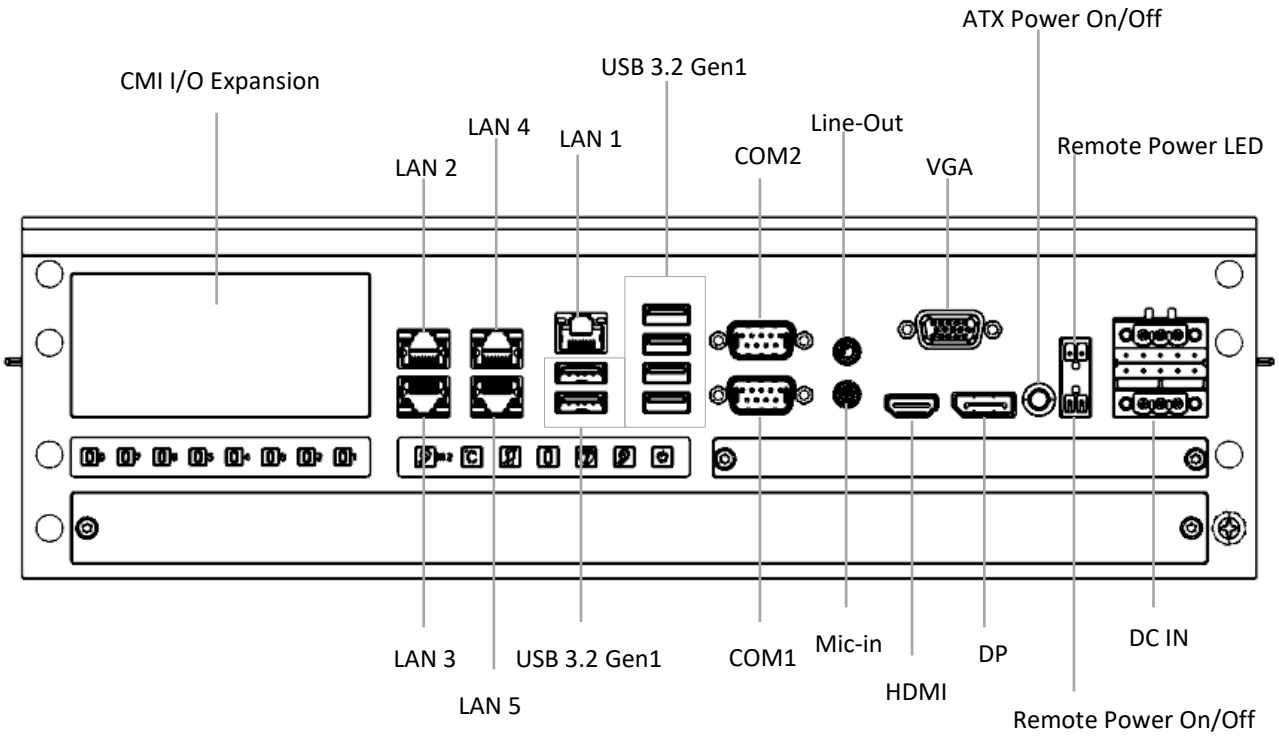

1.3.2 Top

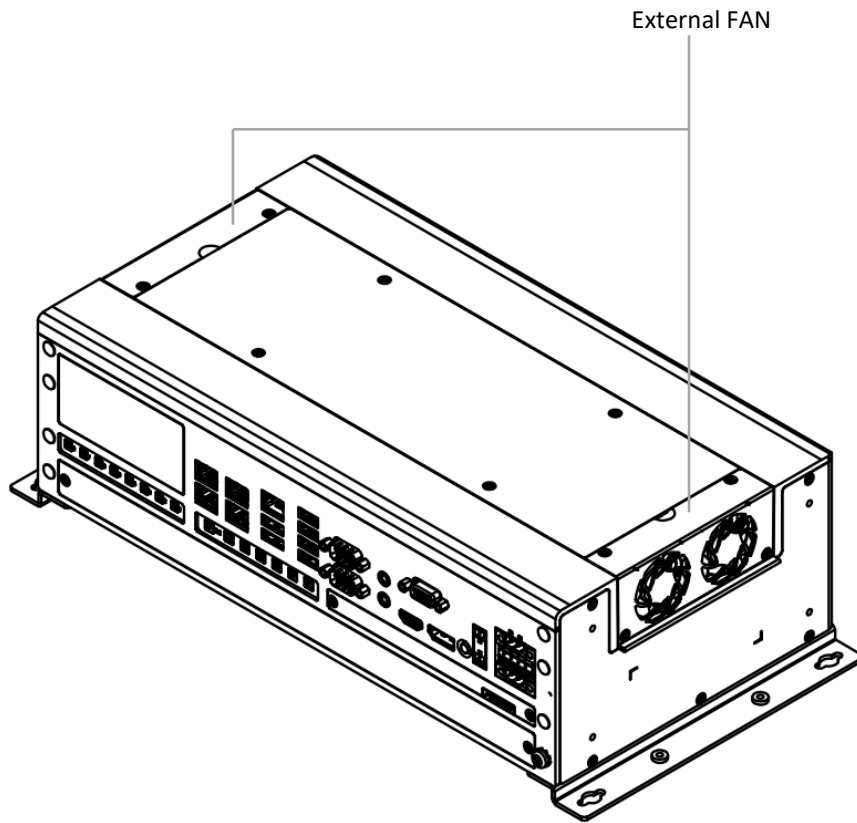

1.4 Dimensions

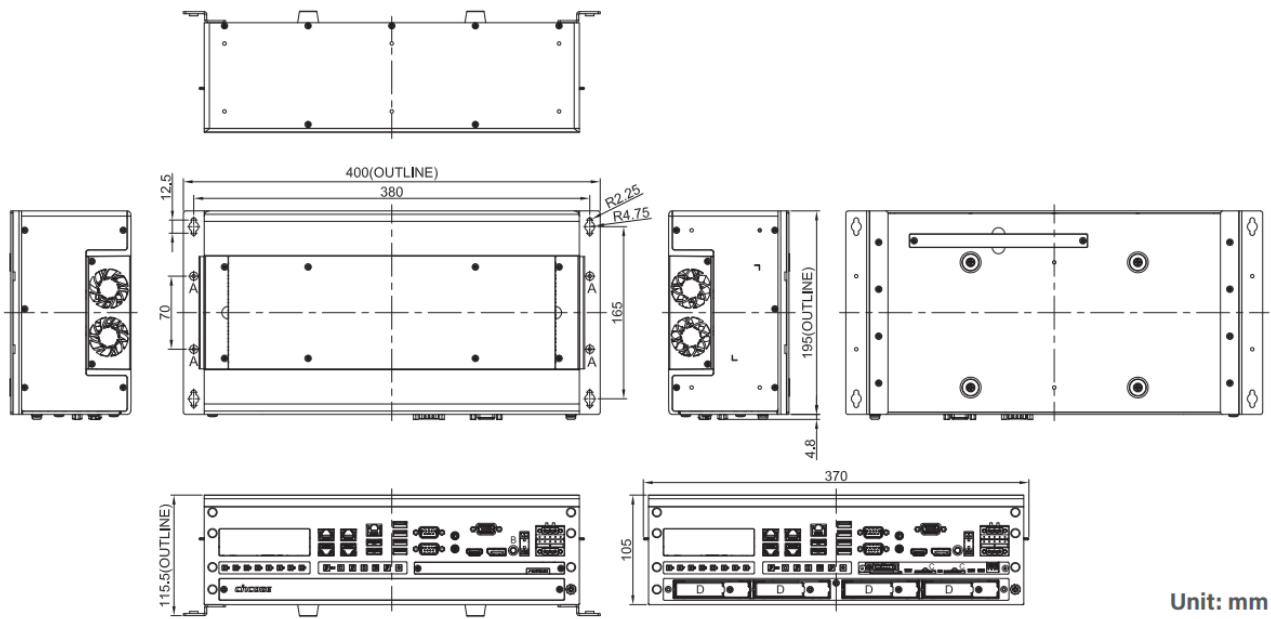

Unit: mm



Chapter 2

Switches & Connectors

2.1 Location of Switches and Connectors

2.1.1 Top View

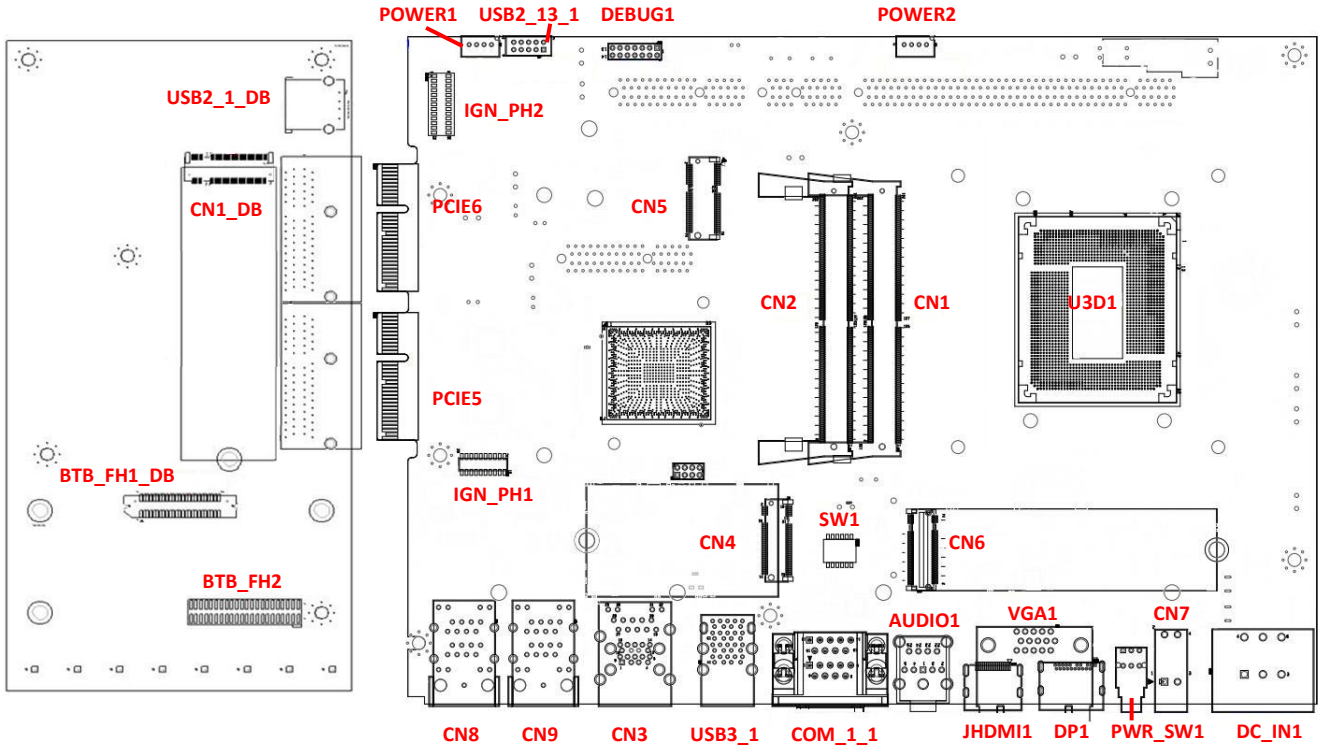

2.1.2 Bottom View

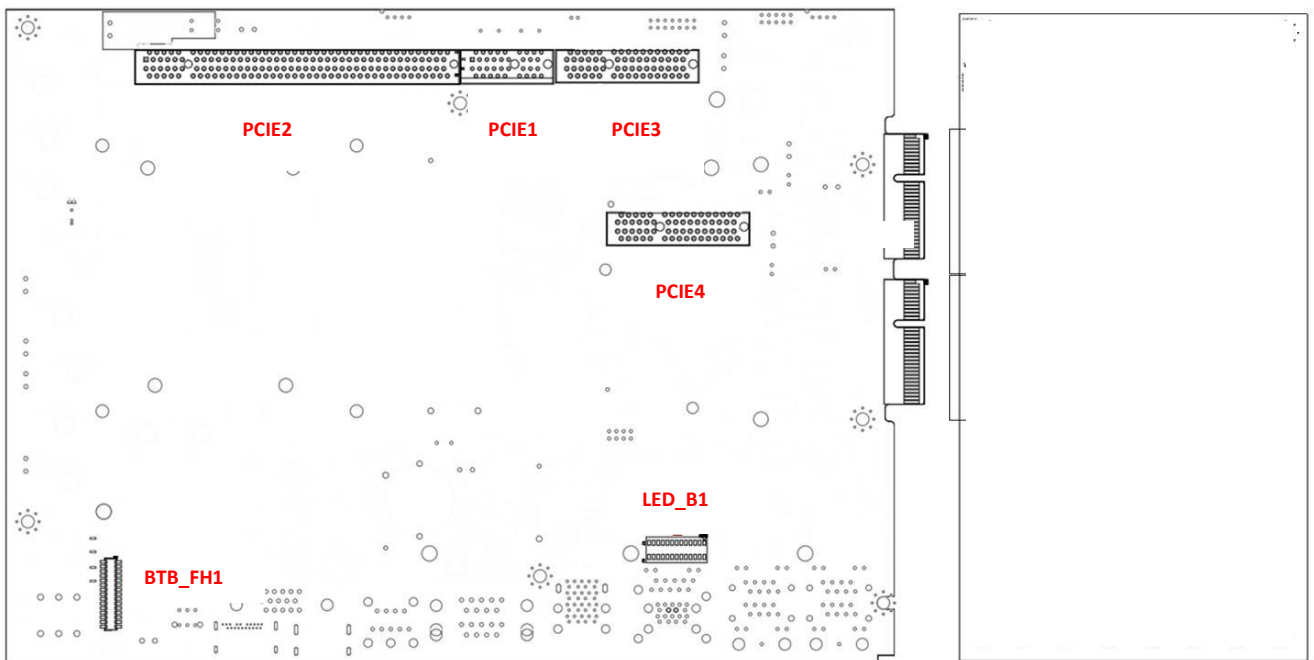

2.2 Switches and Connectors Definition

List of Switch

Location	Definition
AT_ATX1_1	AT/ATX Power Mode Switch (in Maintenance Zone)
CLR_CMOS1_1	Clear COMS Switch (in Maintenance Zone)
PWR_SW1	Power Button with Power On LED
Reset1_1	Reset Switch (in Maintenance Zone)
SW1	Super CAP Switch and COM1~2 Power Select Switch

List of Connector

Location	Definition
AUDIO1	2 IN 1 Audio Phone Jack for Headphone line out & MIC phone in
BTB_FH1	Switch board Female Header for Maintenance Zone Board
BTB_FH1_DB	CMI LAN BTB Connector (Support PoE)
BTB_FH2	CMI DIO/COM BTB Connector
CN1, CN2	DDR5 SO-DIMM Socket
CN1_DB	M.2 KEY B 2280 Socket (Support PCIE Interface)
CN3	Giga LAN RJ45 Connector (LAN1) + USB3.2 Gen1 Port x2
CN4	M.2 KEY B 3042/3052 Socket (Support PCIE/USB3/SATA Interface)
CN5	M.2 Key E Socket (Support PCIE / CNVi Interface)
CN6	M.2 Key M Socket (Support NVMe/ SATA SSD Module)
CN7	Remote Power on/off & Remote Power LED Connector
CN8	2.5 GbE LAN Connector x 2 (LAN2, LAN3)
CN9	2.5 GbE LAN Connector x 2 (LAN4, LAN5)
COM_1_1	RS232 / RS422 / RS485 Supported DB9 Connector x2 (COM1, COM2)
DC_IN1	Dual Row 6 Pins DC 9-48V Power Input with Power Ignition Connector
DEBUG1	Debug Port Male Header
DP1	Display Port Connector
IGN_PH1	PSE Board to Board Male Header
IGN_PH2	IGN Control Board to Board Female Header
JHDMI1	HDMI Connector
LED_B1	LED Board to Board Connector for NVMe HDD / IGN Thermal / IGN Power / GPIO / PoE Function / SATA HDD / System Power LED
POWER1	PWM Fan Connector (FAN OUT Control)
POWER2	PWM Fan Connector (FAN IN Control)
U3D1	CPU Socket
USB2_1_DB	Internal USB 2.0 Box Header (1 Port)
USB2_13_1	Internal USB 2.0 Box Header (2 Ports)
USB3_1	USB3.2 Gen1 Port x4
VGA1	DB15 VGA Connector

2.3 Definition of Switches

AT_ATX1_1 : AT / ATX Power Mode Switch

Switch	Definition
Left	AT Power Mode
Right	ATX Power Mode (Default)



CLR_CMOS1_1 : Clear CMOS Switch

Switch	Definition
Left	Clear CMOS
Right	Normal (Default)



PWR_SW1 : Power Button

Switch	Definition
Press	Power on the System



RESET1_1 : Reset Switch

Switch	Definition
Press	Reset the System



SW1 : Super CAP SW and COM1~2 with Power Select

Location	Function	DIP1	DIP2
SW1	Super Cap	Enabled	ON (Default)
		Disabled	OFF
			ON (Default)

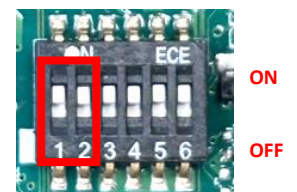

Location	Function	DIP3	DIP4
SW1	COM1	RI	ON (Default)
		5V	ON
		12V	OFF
			ON (Default)
			OFF

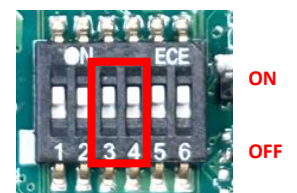

Location	Function	DIP5	DIP6
SW1	COM2	RI	ON (Default)
		5V	ON
		12V	OFF
			SW1
			OFF
			OFF

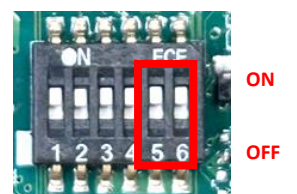

2.4 Definition of Connectors

CN1_DB : M.2 Key B 2280 Socket (Support PCIE Interface)

Pin No.	Definition	Pin No.	Definition
1	M2B_CFG3_DB	2	+3V3SB
3	GND	4	+3V3SB
5	GND	6	PULL-UP
7	USB2_CON_P9_DB	8	PULL-UP
9	USB2_CON_N9_DB	10	NC
11	GND	12	KEY PIN
13	KEY PIN	14	KEY PIN
15	KEY PIN	16	KEY PIN
17	KEY PIN	18	KEY PIN
19	KEY PIN	20	NC
21	M2B_CFG0_DB	22	NC
23	NC	24	NC
25	PULL-UP	26	NC
27	GND	28	NC
29	NC	30	NC
31	NC	32	NC
33	GND	34	NC
35	NC	36	NC
37	NC	38	NC
39	GND	40	NC
41	PCIE_RXN2_DB	42	NC
43	PCIE_RXP2_DB	44	NC
45	GND	46	NC
47	PCIE_TXN2_DB	48	NC
49	PCIE_TXP2_DB	50	MPCIE2_RST#_DB
51	GND	52	NC
53	CLK_100M_M2B_NDB	54	PCIE_WAKE#_DB
55	CLK_100M_M2B_PDB	56	NC
57	GND	58	NC
59	NC	60	NC
61	NC	62	NC
63	NC	64	NC
65	NC	66	NC
67	NC	68	NC



69	M2B_CFG1_DB	70	+3VSB
71	GND	72	+3VSB
73	GND	74	+3VSB
75	M2B_CFG2_DB	76	NC

CN3 : Giga LAN RJ45 Connector (LAN1) + USB3.2 Gen1 Port x2

LAN LED Status Definition

Link LED Status	Definition
Steady Green	1 Gbps Network Link
Steady Orange	100 Mbps Network Link
Off	10 Mbps Network Link
Act LED Status	Definition
Blinking Yellow	Data Activity
Steady Yellow	No Activity

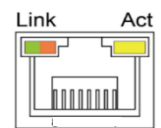

CN4 : M.2 KEY B Socket (Support PCIE/USB3/SATA Interface)

Pin No.	Definition	Pin No.	Definition
1	CFG3	2	+3.3V
3	GND	4	+3.3V
5	GND	6	FULL_CARD_PWR_OFF#
7	USB2_D+	8	W_DISABLE1#
9	USB2_D-	10	DAS/DSS#/LED#1
11	GND	12	KEY PIN
13	KEY PIN	14	KEY PIN
15	KEY PIN	16	KEY PIN
17	KEY PIN	18	KEY PIN
19	KEY PIN	20	I2S_CLK
21	CFG0	22	I2S_RX
23	N/C	24	I2S_TX
25	DPR	26	W_DISALBE2#
27	GND	28	I2S_WAO
29	PERN1/USB3_RX-	30	USIM_RESET
31	PERP1_USB3_RX+	32	USIM_CLK
33	GND	34	USIM_DATA
35	PETN1/USB3_TX-	36	USIM_PWR
37	PETP1/USB3_TX+	38	DEVSLP
39	GND	40	USIM_DET2

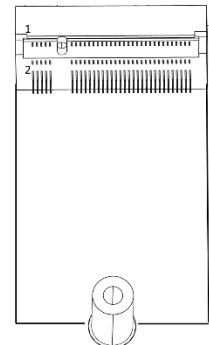

41	PERN0/SATA_RX+	42	USIM_DATA2
43	PERP0_SATA_RX-	44	USIM_CLK2
45	GND	46	USIM_RESET2
47	PETN0/SATA_TX-	48	USIM_PWR2
49	PETP0/SATA_TX+	50	PERST#
51	GND	52	CLKREQ#
53	REFCLKN	54	WAKE#
55	REFCLKP	56	N/C
57	GND	58	N/C
59	N/C	60	N/C
61	N/C	62	N/C
63	N/C	64	N/C
65	N/C	66	USIM_DET
67	N/C	68	SUSCLK
69	CFG1	70	+3.3V
71	GND	72	+3.3V
73	GND	74	+3.3V
75	CFG2		

CN5 : M.2 Key E socket (Support PCIe / CNVi Interface)

Pin No.	Definition	Pin No.	Definition
1	GND	2	+3.3V
3	USB_D+	4	+3.3V
5	USB_D-	6	LED1#
7	GND	8	PCM_CLK
9	WGR_D1n	10	PCM_RSTN
11	WGR_D1p	12	PCM_IN
13	GND	14	PCM_OUT
15	WGR_D0n	16	LED2#
17	WGR_D0p	18	GND
19	GND	20	UART_WAKE#
21	WGR_CLKn	22	BRI_RSP
23	WGR_CLKp	24	Key
25	Key	26	Key
27	Key	28	Key
29	Key	30	Key
31	Key	32	RGI_DT
33	GND	34	RGI_RSP

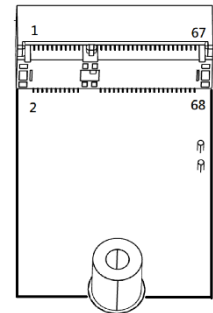

35	PETp0	36	BRI_DT
37	PETn0	38	CLINK_REST
39	GND	40	CLINK_DATA
41	PERp0	42	CLINK_CLK
43	PERn0	44	COEX3
45	GND	46	COEX_TXD
47	REFCLKp0	48	COEX_RXD
49	REFCLKn0	50	SUSCLK
51	GND	52	PERST0#
53	CLKREQ0#	54	W_DISABLE2#
55	PEWAKE0#	56	W_DISABLE1#
57	GND	58	I2C_DATA
59	WTD1n/PETp1	60	I2C_CLK
61	WTD1p/PETn1	62	ALERT
63	GND	64	REFCLK
65	WTD0n/PERp1	66	PERST1#
67	WTD0p/PERn1	68	CLKREQ1#
69	GND	70	PEWAKE1#
71	WTCLKn/REFCLKp1	72	+3.3V
73	WTCLKp/REFCLKn1	74	+3.3V
75	GND		

CN6 : M.2 Key M Socket (Support NVMe/ SATA SSD Module)

Pin No.	Definition	Pin No.	Definition
1	CFG3	2	+3.3V
3	GND	4	+3.3V
5	PERn3	6	N/A
7	PERp3	8	N/A
9	GND	10	DAS/DSS*
11	PETn3	12	+3.3V
13	PETp3	14	+3.3V
15	GND	16	+3.3V
17	PERn2	18	+3.3V
19	PERp2	20	N/A
21	CFG0	22	N/A
23	PETn2	24	N/A
25	PETp2	26	N/A
27	GND	28	N/A

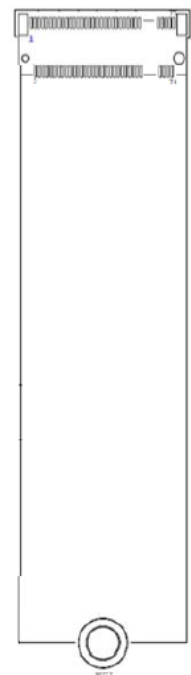

29	PERn1	30	N/A
31	PERp1	32	N/A
33	GND	34	N/A
35	PETn1	36	N/A
37	PETp1	38	DEVSLP
39	GND	40	SMB_CLK
41	PERn0/SATA_B+	42	SMB_DATA
43	PERp0/SATA_B-	44	SMB_ALERT#
45	GND	46	N/A
47	PETn0/SATA_A-	48	N/A
49	PETp0/SATA_A+	50	PERST#
51	GND	52	CLKREQ#
53	REFCLKn	54	PEWAKE#
55	REFCLKp	56	N/A
57	GND	58	N/A
59	Key	60	Key
61	Key	62	Key
63	Key	64	Key
65	Key	66	Key
67	N/A	68	SUSCLK
69	PEDET/CFG1	70	+3.3V
71	GND	72	+3.3V
73	GND	74	+3.3V
75	CFG2		

CN7 : Remote Power on/off & Remote Power LED Connector

Remote Power LED connector can only connect an external LED indicator up to 10mA @ 3.3V.

Connector Type: Terminal Block 2X2 4-pin, 3.5mm pitch

Pin	Definition
1	RMT_PWR_BTN_N
2	RMT_P_LED
3	GND
4	GND

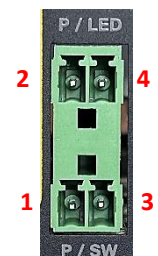

WARNING
(AVERTIR)

Do not apply power to this connector! This port is used to connect a SWITCH!

(Ne mettez pas sous tension ce connecteur! Ce port est utilisé pour connecter un SWITCH!)

COM_1_1 (COM1, COM2) : RS232 / RS422 / RS485 Connector x2

Connector Type: 9-pin D-Sub

Pin	RS232 Definition	RS422 / 485 Full Duplex Definition	RS485 Half Duplex Definition
1	DCD	TX-	DATA -
2	RXD	TX+	DATA +
3	TXD	RX+	
4	DTR	RX-	
5	GND		
6	DSR		
7	RTS		
8	CTS		
9	RI		



CN8/CN9 : 2.5 GbE LAN Connector x 2 (LAN2, LAN3/ LAN4, LAN5)

LAN LED Status Definition

Link LED Status	Definition
Steady Green	2.5 Gbps Network Link
Steady Orange	1 Gbps Network Link
Off	100 Mbps/ 10 Mbps Network Link
Act LED Status	Definition
Blinking Yellow	Data Activity
Steady Yellow	No Activity

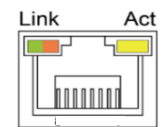

DC_IN1 : 3 Pins x2 DC 9-48V Power Input with Power Ignition Connector

Connector Type: 2x 3-pins Terminal Block , 5.0mm pitch

Pin	Definition	Pin	Definition
1	9_48VSB_IN	4	9_48VSB_IN
2	9_32VSB_ACC (IGN)	5	NC
3	GND	6	GND

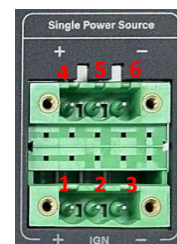

**WARNING
(AVERTIR)**

Only Single Power Source can connect to DC_IN1. Please disconnect the power source before mounting the DC power cables or connecting the DC power connector to system. (Une seule source d'alimentation peut être connectée à DC_IN1. Veuillez débrancher la source d'alimentation avant de monter les câbles d'alimentation DC ou de connecter le connecteur d'alimentation DC au système.)

LED_B1 : LED Board to Board Connector for NVMe HDD / IGN Thermal / IGN Power / GPIO / PoE / PoE Function / SATA HDD / System Power LED

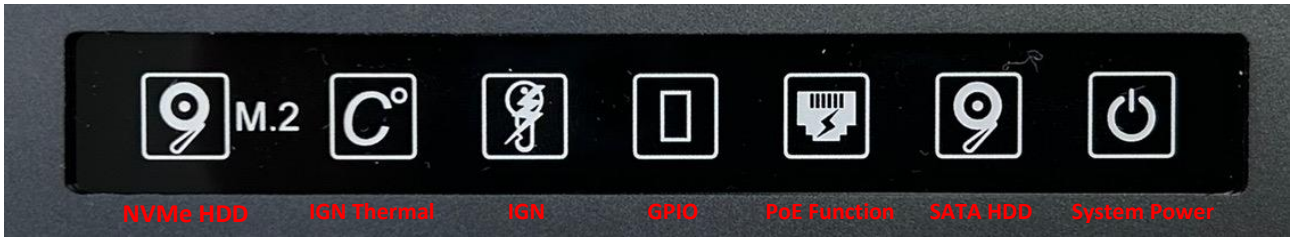

LED Type	Status	LED Color		
NVMe HDD LED	No activity	No light		
	Data activity	Blinking Yellow		
IGN Thermal LED	CPU Temp $\leq 65^{\circ}\text{C}$	No light		
	$65^{\circ}\text{C} < \text{CPU Temp} \leq 70^{\circ}\text{C}$	Blue		
	$70^{\circ}\text{C} < \text{CPU Temp} \leq 75^{\circ}\text{C}$	Red		
	$75^{\circ}\text{C} < \text{CPU Temp}$	Blinking Red		
IGN LED	IGN module not installed	No light		
	IGN module installed	IGN disabled	Green	
		IGN enabled	ACC OFF	Blue
			ACC ON	Green
GPIO LED	No activity	No light		
	GPIO activity	Green		
PoE Function LED	PoE module not installed	No light		
	PoE module installed	Green		
SATA HDD LED	No activity	No light		
	Data activity	Blinking Yellow		
System Power LED	Power off	Blue		
	Power on	Green		
	Standby	Blinking Green and Blue		

POWER1 : PWM Fan Connector (FAN OUT Control)

System Thermal Sensor for System Smart Fan

Connector Type: 1x4 4-pin Wafer, 2.0mm pitch

Pin No.	Definition
1	GND
2	+12V
3	FAN_IN
4	FAN_PWMOUT

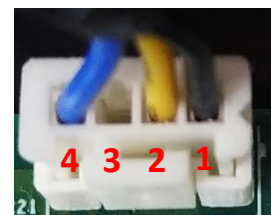

POWER2 : PWM Fan Connector (FAN IN Control)

CPU Thermal Sensor for CPU Smart Fan

Connector Type: 1x4 4-pin Wafer, 2.0mm pitch

Pin No.	Definition
1	GND
2	+12V
3	FAN_IN
4	FAN_PWMOUT

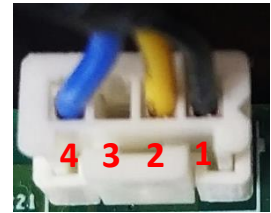

POWER1 (FAN OUT Control)



POWER2 (FAN IN Control)

USB2_13_1 : Internal USB 2.0 Box Header (2 Ports)

Connector Type: 2x5 10-pin Wafer, 2.0mm pitch

Pin	Definition	Pin	Definition
1	VBUS(+5V)	2	VBUS(+5V)
3	USB_D0-	4	USB_D1-
5	USB_D0+	6	USB_D1+
7	GND	8	GND
9	Chassis_GND	10	Chassis_GND

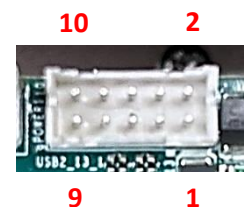

2.5 Definition of Switches and Connectors on Optional Modules

2.5.1 CMI-M12LAN01 Module

LAN Port Connector Pin Definitions

Connector Type: M12 A coded 8pin connector

Pin	Definition	Pin	Definition
1	2_LAN1_0+	2	2_LAN1_0-
3	2_LAN1_1+	4	2_LAN1_2+
5	2_LAN1_2-	6	2_LAN1_1-
7	2_LAN1_3+	8	2_LAN1_3-

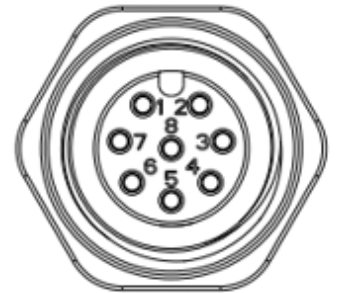

2.5.2 CMI-XM12LAN01 Module

LAN Port Connector Pin Definitions

Connector Type: M12 X coded 8pin connector

Pin	Definition	Pin	Definition
1	D1+	2	D1-
3	D2+	4	D2-
5	D4+	6	D4-
7	D3-	8	D3+

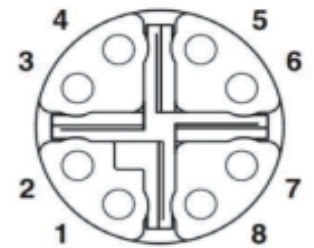

2.5.3 CMI-2P5GLAN02 Module

LAN (I225) LED Status Definition

Link Speed LED Status	Definition
Steady Green	2.5 Gbps Network Link
Steady Orange	1 Gbps Network Link
Off	100 Mbps Network Link
Off	10 Mbps Network Link
Link Act LED Status	Definition
Blinking Yellow	Link and Data Activity
Steady Yellow	Link but No Activity

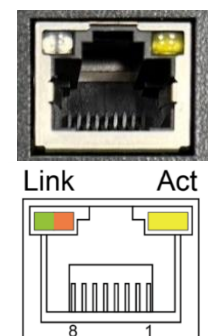

2.5.4 CMI-10GXM12LAN02 Module

LAN (X550) LED Status Definition

Link Speed LED Status	Definition
Steady Green	10 Gbps Network Link
Steady Orange	1 Gbps Network Link
Off	100 Mbps Network Link
Link Act LED Status	Definition
Blinking Yellow	Link and Data Activity
Steady Yellow	Link but No Activity

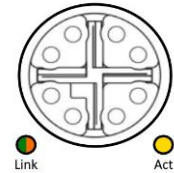

LAN Port Pin Definitions

Connector Type: M12 X coded 8pin connector

Pin	Definition	Pin	Definition
1	MDX0+	2	MDX0-
3	MDX1+	4	MDX1-
5	MDX3+	6	MDX3-
7	MDX2-	8	MDX2+
9	GND		

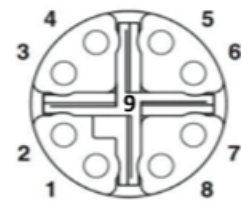

2.5.5 CMI-DIO04 Module

DIO1/DIO2 (on the module): Digital IN Connector/Digital OUT Connector

Connector Type: Terminal Block 1X20 20-pin, 3.5mm pitch

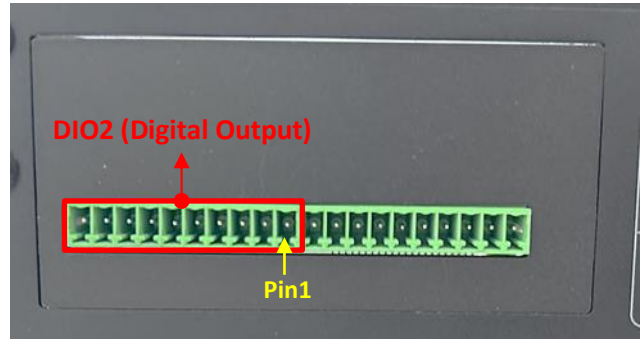
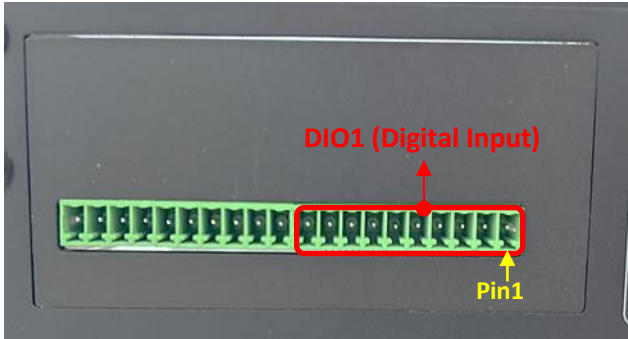

Location	Pin	Definition
DIO1	1	XCOM+ (DC INPUT)
	2	DI1
	3	DI2
	4	DI3
	5	DI4
	6	DI5
	7	DI6
	8	DI7
	9	DI8
	10	XCOM- (GND)

Location	Pin	Definition
DIO2	1	XCOM+ (DC INPUT)
	2	DO1
	3	DO2
	4	DO3
	5	DO4
	6	DO5
	7	DO6
	8	DO7
	9	DO8
	10	XCOM- (GND)

2.5.6 CMI-COM04 Module

COM3 / COM4 : RS232 / RS422 / RS485 Connector

Connector Type: 9-pin D-Sub

Pin	RS232 Definition	RS422 / 485 Full Duplex Definition	RS485 Half Duplex Definition
1	DCD	TX-	DATA -
2	RXD	TX+	DATA +
3	TXD	RX+	
4	DTR	RX-	
5	GND		
6	DSR		
7	RTS		
8	CTS		
9	RI		



SW2 on the Module : COM3 / COM4 Power Select

Location	Function		DIP1	DIP2
SW2	COM3	RI	ON (Default)	ON (Default)
		5V	ON	OFF
		12V	OFF	OFF

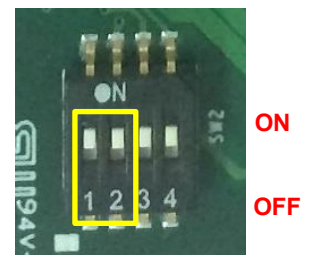

Location	Function		DIP3	DIP4
SW2	COM4	RI	ON (Default)	ON (Default)
		5V	ON	OFF
		12V	OFF	OFF

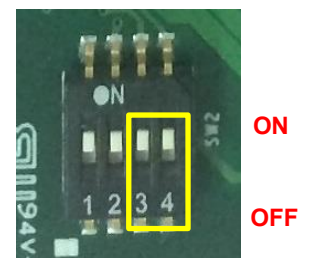

2.5.7 CMI-CAN01 Module

COM1 and COM2 (on the module) : CAN BUS Connector

Connector Type: 9-pin D-Sub

Pin	CAN BUS1 Definition	CAN BUS2 Definition
1	N.C	N.C
2	CAN1L	CAN2L
3	GND	GND
4	N.C	N.C
5	N.C	N.C
6	GND	GND
7	CAN1H	CAN2H
8	N.C	N.C
9	N.C	N.C



SW1: COM1/COM2 120Ω Terminating Resistor Select

Location	Function		DIP1	DIP2
SW1 on CMI-CAN Module	COM1	Enabled	OFF (Default)	OFF (Default)
		Disabled	ON	ON



Location	Function		DIP1	DIP2
SW1 on CMI-CAN Module	COM2	Enabled	OFF (Default)	OFF (Default)
		Disabled	ON	ON



2.5.8 CFM-IGN03 Module

SW1_1 : IGN Module Timing Setting Switch

Set shutdown delay timer when ACC is turned off

Pin 1	Pin 2	Pin 3	Pin 4	Definition
ON (IGN Enabled) / OFF (IGN Disabled)	ON	ON	ON	0 second
	ON	ON	OFF	1 minute
	ON	OFF	ON	5 minutes
	ON	OFF	OFF	10 minutes
	OFF	ON	ON	30 minutes
	OFF	ON	OFF	1 hour
	OFF	OFF	ON	2 hours
	OFF	OFF	OFF	Reserved (0 second)



Default setting of Pin1 to Pin4 is OFF / OFF / OFF / OFF.

24V_12V_1 : IGN Module Voltage Mode Setting Switch

12V / 24V Car Battery Switch

Switch	Definition
Left	12V Car Battery Input
Right	24V Car Battery Input (Default)



2.5.9 GEB-3301 Module

2.5.9.1 Location of Switches and Connectors

Top View

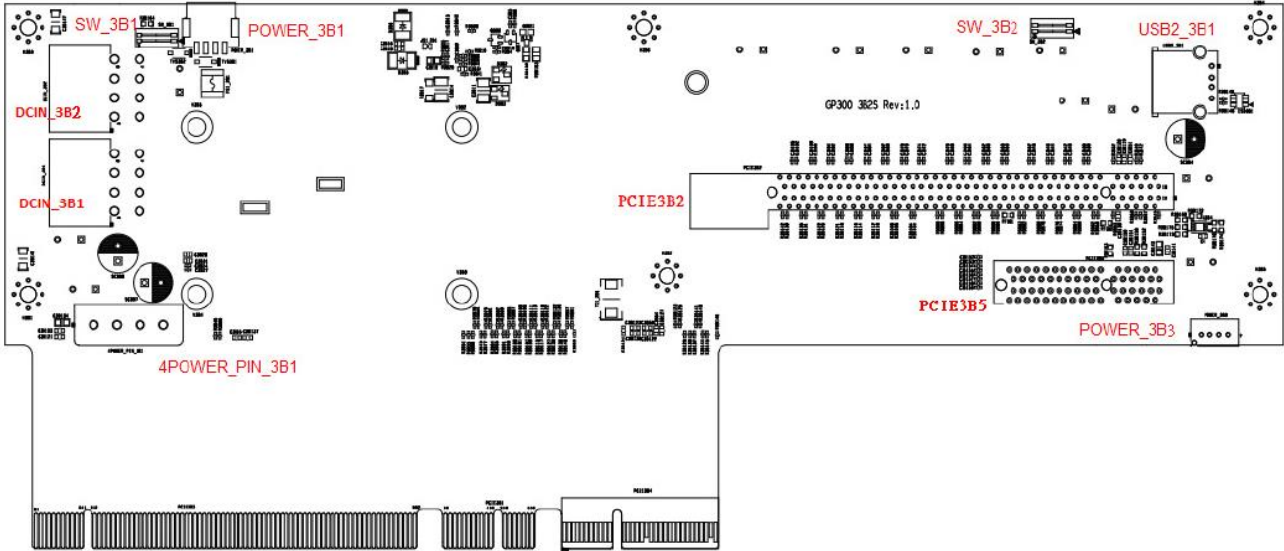

Bottom View

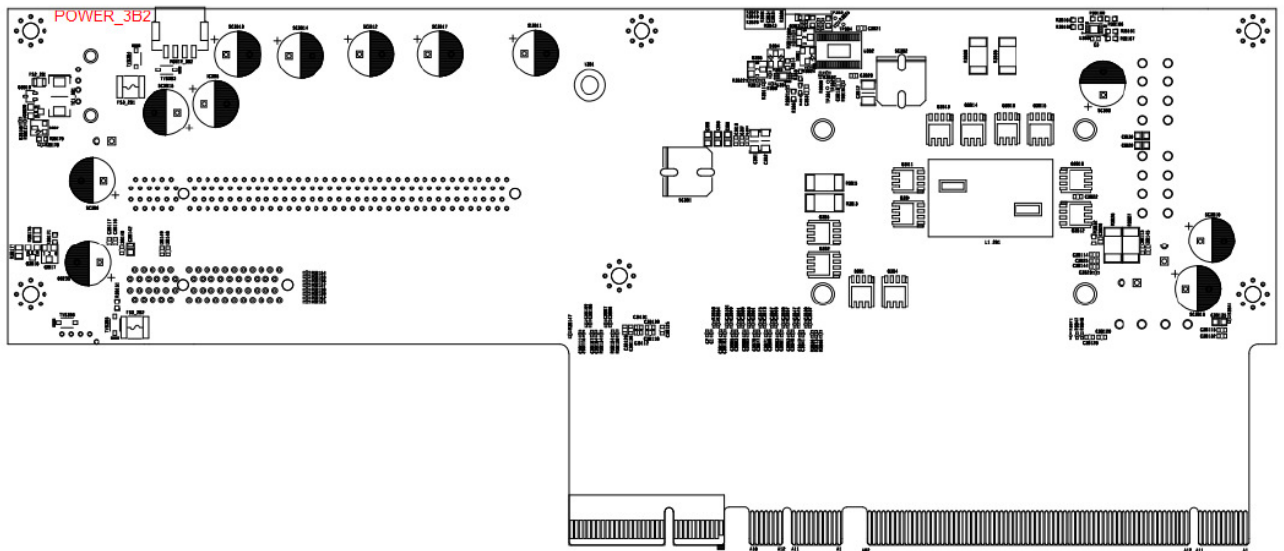

2.5.9.2 Switches and Connectors Definition

List of Switches and Connectors

Location	Definition
4POWER_PIN_3B1	Power pin connector for Graphic card 4 power pin
DCIN_3B1	Power pin connector for Graphic card 8+8 power pin
DCIN_3B2	Power pin connector for Graphic card 8+8 power pin
PCIE3B2	Standard PCIe16 slot
PCIE3B5	Standard PCIe4 slot
POWER_3B1	Fan power connector
POWER_3B2	Fan power connector
POWER_3B3	Fan power connector
SW_3B1	Smart Fan on/off switch (for POWER_3B1)
SW_3B2	Smart Fan on/off switch (for POWER_3B2 & POWER_3B3)
USB2_3B1	Standard USB 2.0 connector

2.5.9.3 Definition of Switches and Connectors

4POWER_PIN_3B1: Power pin connector

Pin	Definition
1	+12V
2	GND
3	GND
4	NC



DCIN_3B1/ DCIN_3B2: Graphic card 8+8 power pin

Pin	Definition	Pin	Definition
1	GND	5	+12V
2	GND	6	+12V
3	GND	7	+12V
4	GND	8	GND

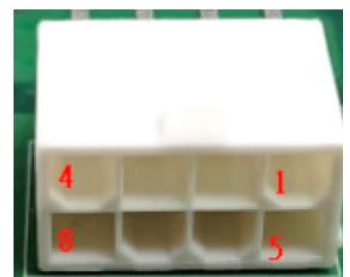

POWER_3B3: Fan power connector

Pin	Definition
1	GND
2	+12V
3	NC
4	PWM

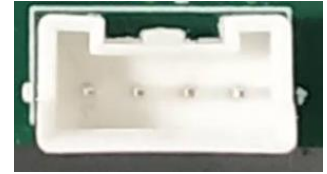

1 4

SW_3B1: Smart Fan on/off switch (for POWER_3B1)

Location	Function		Switch
DIP1	POWER_3B1	Enabled	ON (Default)
		Disabled	OFF



ON
OFF

SW_3B2: Smart Fan on/off switch (for POWER_3B2 & POWER_3B3)

Location	Function		Switch
DIP1	POWER_3B2	Enabled	ON (Default)
		Disabled	OFF
DIP2	POWER_3B3	Enabled	ON (Default)
		Disabled	OFF

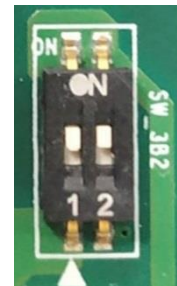

ON
OFF

2.5.10 GEB-3601 Module

2.5.10.1 Location of Switches and Connectors

Top View

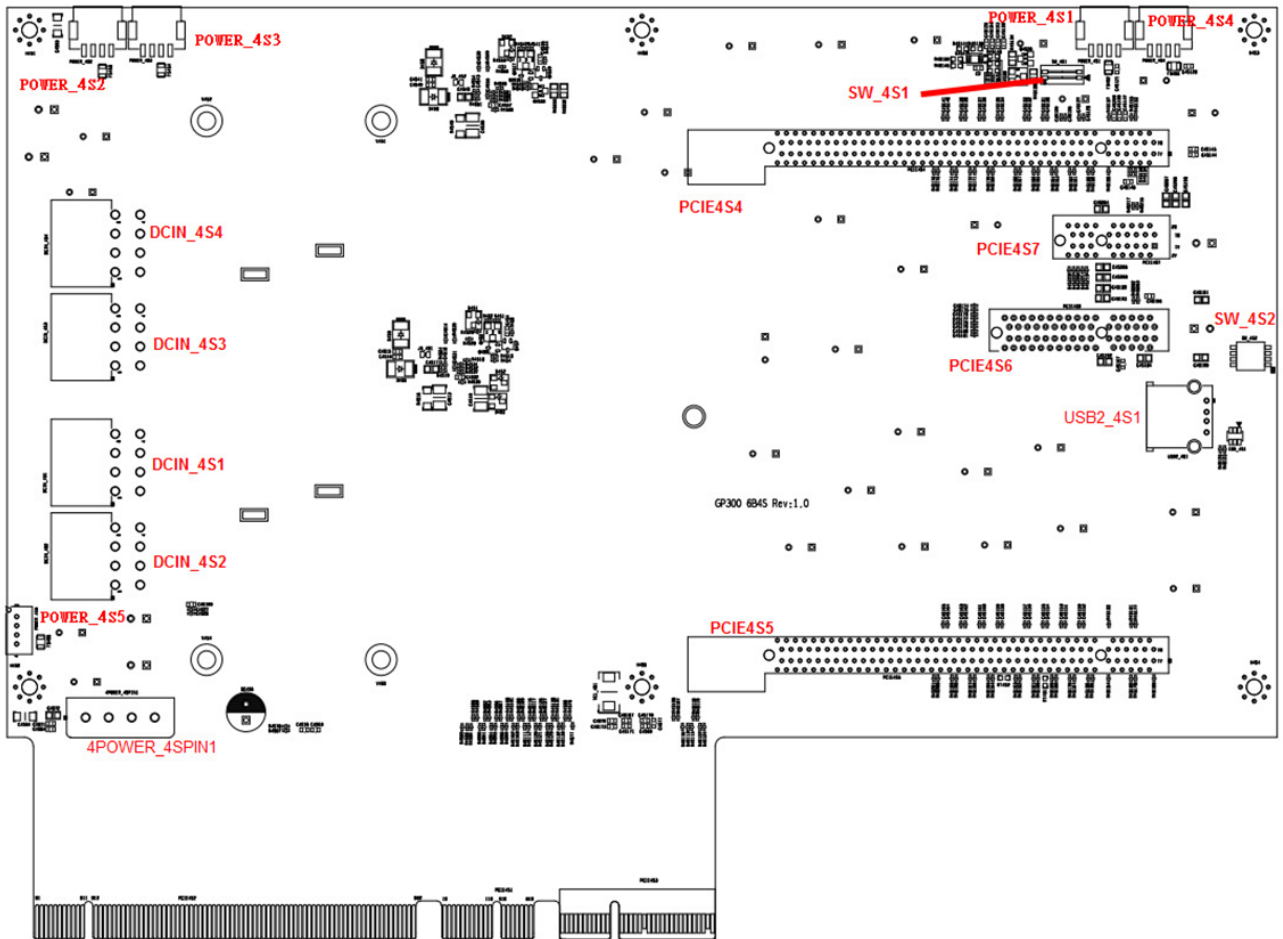

Bottom View

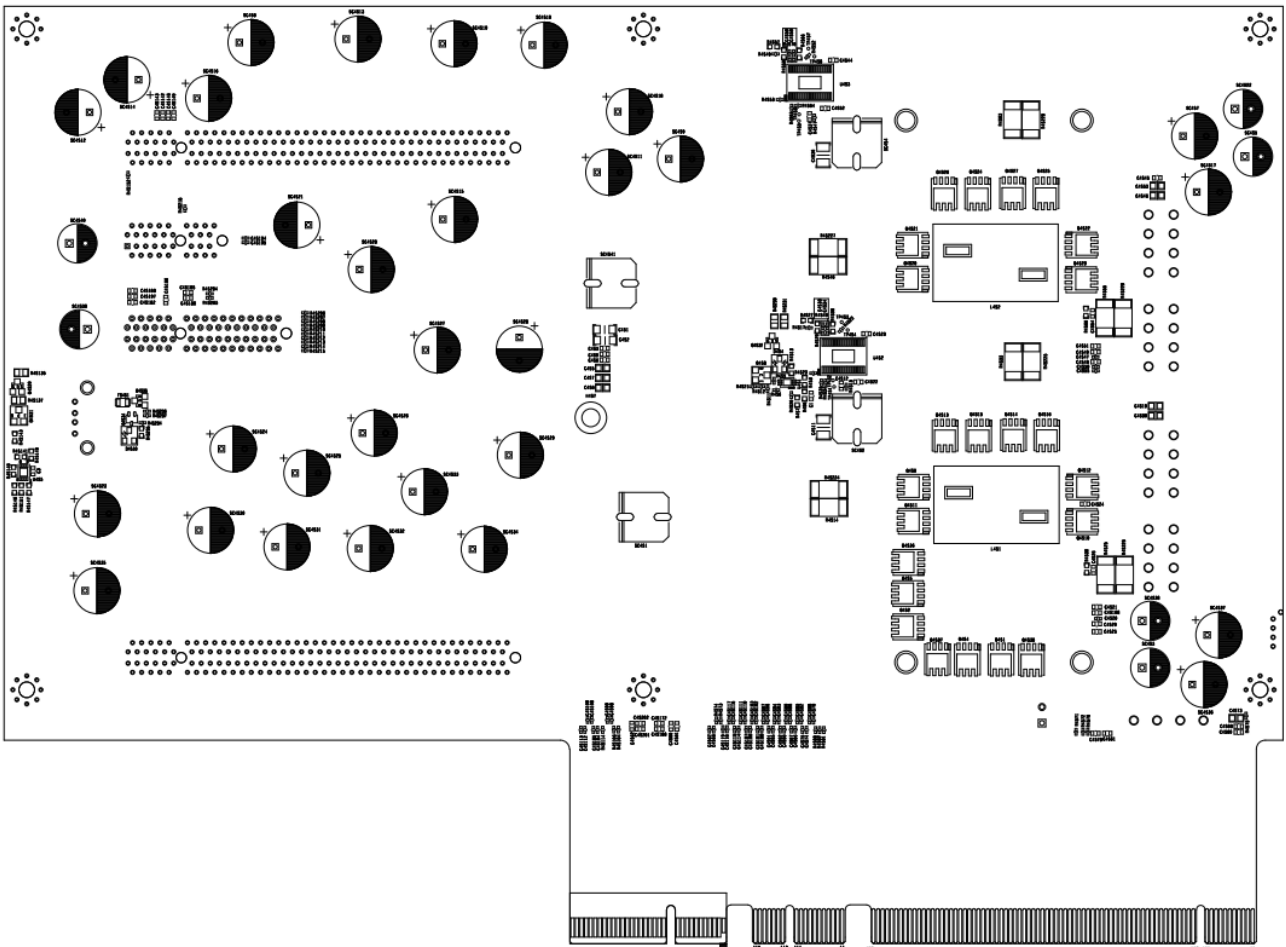

2.5.10.2 Switches and Connectors Definition

List of Switches and Connectors

Location	Definition
4POWER_4SPIN1	Graphic power connector
DCIN_4S1, DCIN_4S2	Graphic Card 8+8 power connector
DCIN_4S3, DCIN_4S4	Graphic Card 8+8 power connector
PCIE4S4	PClex8 with x16 slot
PCIE4S5	PClex8 with x16 slot
PCIE4S6	Standard PClex4 slot
PCIE4S7	Standard PClex1 slot
POWER_4S1	Fan power connector
POWER_4S2	Fan power connector
POWER_4S3	Fan power connector
POWER_4S4	Fan power connector
POWER_4S5	Fan power connector
SW_4S1	Smart Fan on/off switch (for POWER_4S1 & POWER_4S4)
SW_4S2	Smart Fan on/off switch (for POWER_4S2 & POWER_4S3 & POWER_4S5)
USB2_4S1	Standard USB 2.0 connector

2.5.10.3 Definition of Switches and Connectors

4POWER_4SPIN1: Power pin connector

Pin	Definition
1	+12V
2	GND
3	GND
4	NC



DCIN_4S1/ DCIN_4S2/ DCIN_4S3/ DCIN_4S4: for Graphic card 8+8 power pin

Pin	Definition	Pin	Definition
1	GND	5	+12V
2	GND	6	+12V
3	GND	7	+12V
4	GND	8	GND

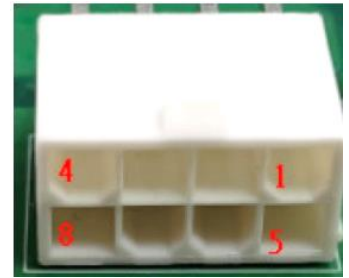

SW_4S1: Smart Fan on/off switch (for POWER_4S1 & POWER_4S4)

Location	Function	Switch
DIP1	POWER_4S1	Enabled ON (Default)
		Disabled OFF
DIP2	POWER_4S4	Enabled ON (Default)
		Disabled OFF





ON
OFF

SW_4S2: Smart Fan on/off switch (for POWER_4S2 & POWER_4S3 & POWER_4S5)

Location	Function	Switch
DIP1	POWER_4S2	Enabled ON (Default)
		Disabled OFF
DIP2	POWER_4S3	Enabled ON (Default)
		Disabled OFF
DIP3	POWER_4S5	Enabled ON (Default)
		Disabled OFF



ON
OFF



Chapter 3

System Setup

3.1 Removing Top Cover



WARNING
(AVERTIR)

In order to prevent electric shock or system damage, must turn off power and disconnect the unit from power source before removing the chassis cover.

(Afin d'éviter tout risque d'électrocution ou d'endommagement du système, vous devez couper l'alimentation et débrancher l'appareil de la source d'alimentation avant de retirer le couvercle du châssis.)

Step 1. Loosen the 4 screws to remove the top plate.

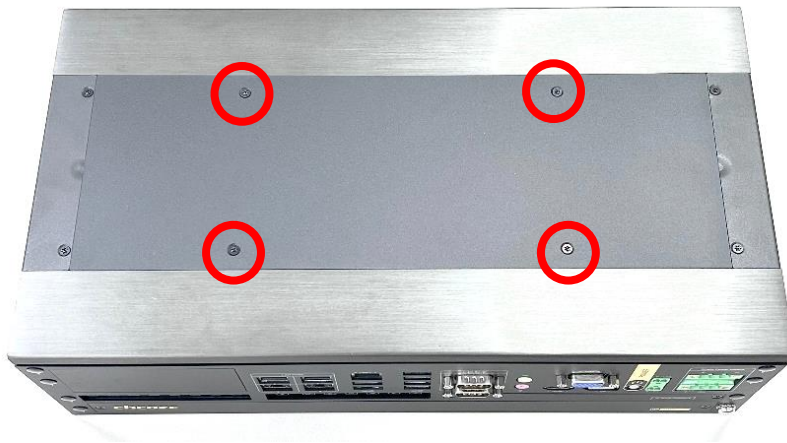

Step 2. Loosen the two screws on the top cover. Please note that if the CPU is included with the shipment, the factory will secure these two screws to fix the CPU in place. However, if the CPU is not included (for users who wish to install it themselves), the screws will not be fastened; In this case, please disregard this step.



Step 3. Loosen the 6 screws on the left, right, and rear panels of the system.



Left Panel

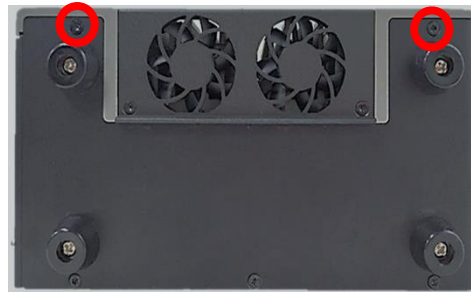

Right Panel

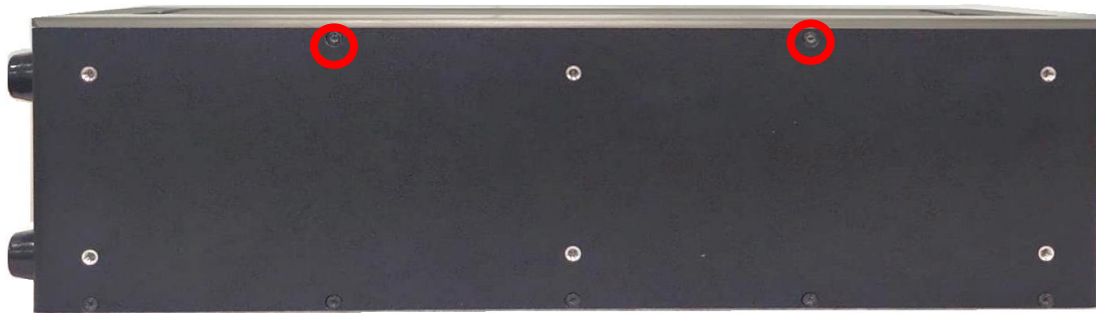

Rear Panel

Step 4. Remove the top cover from the chassis.



Step 5. Place the top cover aside gently as shown below.

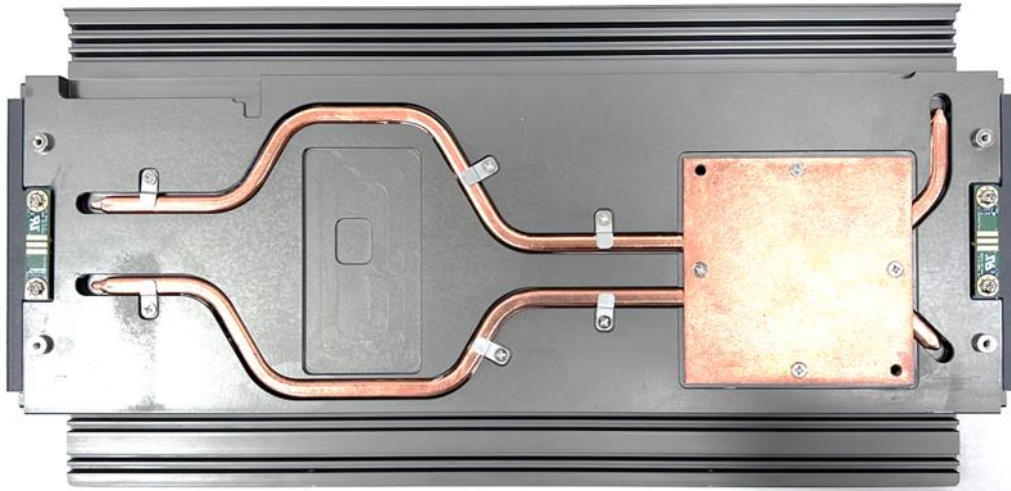

CAUTION
(ATTENTION)

During the following entire installation procedures, please be careful not to touch the pins on the fan power connector. Otherwise, the fan power connector will be damaged and may not work properly.

(Pendant toute la procédure d'installation, veillez à ne pas toucher les broches du connecteur d'alimentation du ventilateur. Sinon, le connecteur d'alimentation du ventilateur pourrait être endommagé et pourrait ne pas fonctionner correctement.)

3.2 Installing CPU & Thermal Block



WARNING
(AVERTIR)

After replacing the CPU, please perform a Clear CMOS before powering on. According to Intel documentation (Clear CMOS after Hardware Configuration Change, Document Number: 337986-001), if you do not perform a Clear CMOS, the BIOS will apply settings from the old CPU to the new CPU, which may cause performance issues or startup failures. Therefore, Cincoze performs a Clear CMOS procedure before shipping. When customers power on the system for the first time, it will take several minutes to start. This is normal. During this process, the system will POST three times, and the Power LED will alternate between green and blue lights.

(Après avoir remplacé le CPU, veuillez effectuer un Clear CMOS avant de mettre sous tension. Selon la documentation Intel (Clear CMOS after Hardware Configuration Change, Document Number: 337986-001), si vous n'effectuez pas un Clear CMOS, le BIOS appliquera les paramètres de l'ancien CPU au nouveau CPU, ce qui peut entraîner des problèmes de performance ou des échecs de démarrage. Par conséquent, Cincoze effectue une procédure de Clear CMOS avant l'expédition. Lorsque les clients mettent le système sous tension pour la première fois, il faudra plusieurs minutes pour démarrer. Cela est normal. Pendant ce processus, le système effectuera trois fois le POST et la LED d'alimentation alternera entre les lumières verte et bleue.)

Step 1. Locate the CPU socket.

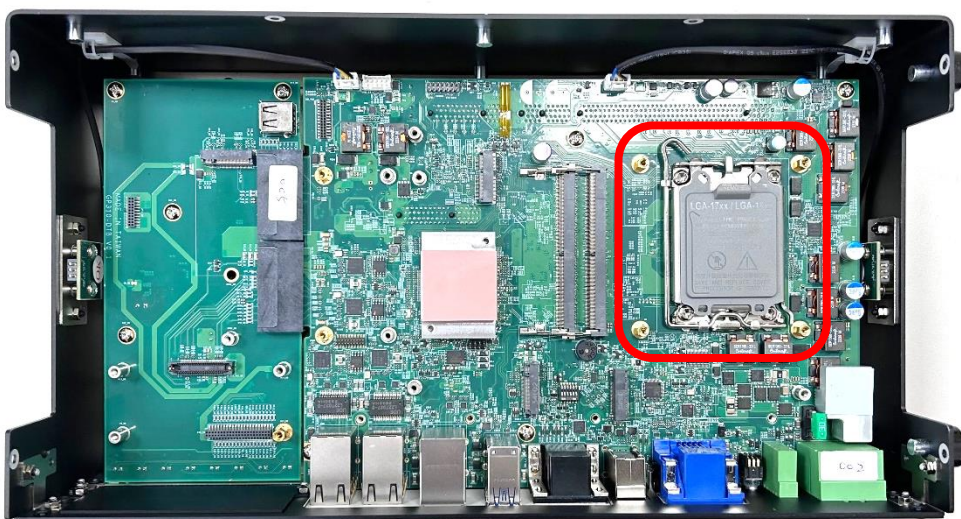

Step 2. Press and pull the lever to the side; it will then automatically bump up, unlocking the socket cover.



Step 3. Lift the lever to the fully open position as shown below.

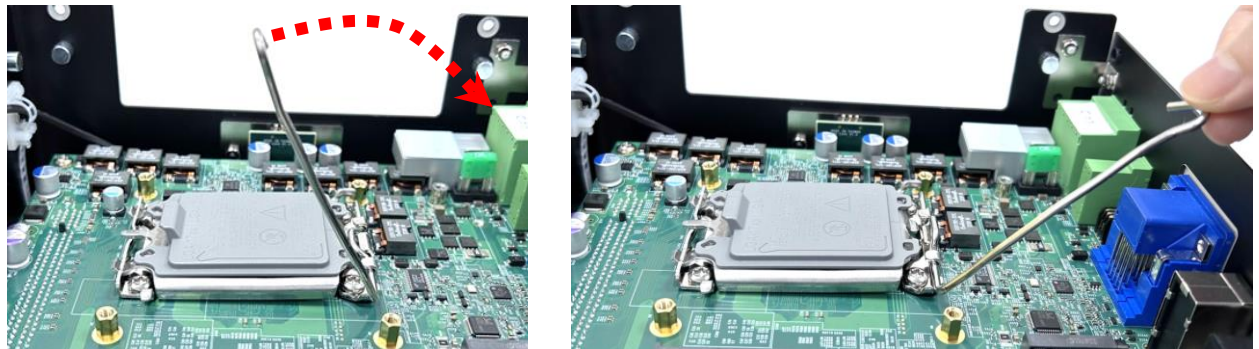

Step 4. Hold the end of the lead connected to the socket cover and lift it to the fully open position, as shown below.

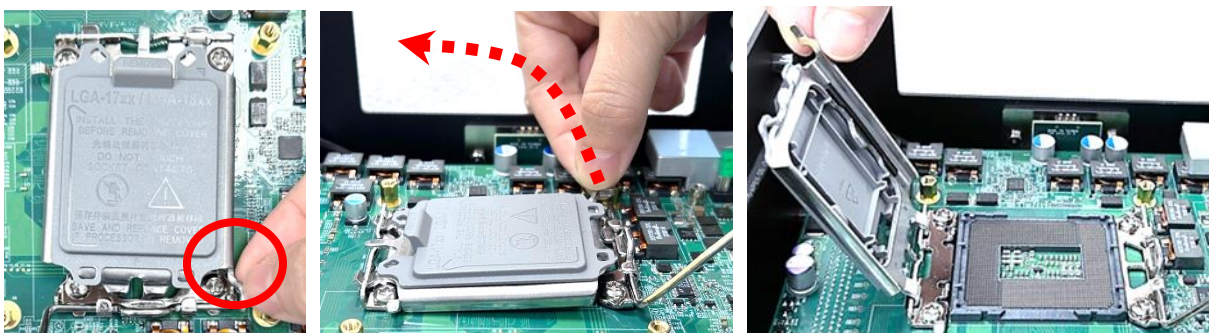

Step 5. Locate the notches of the socket. Then hold the CPU by the edges and put on the CPU gently with aligning the notches of the socket.

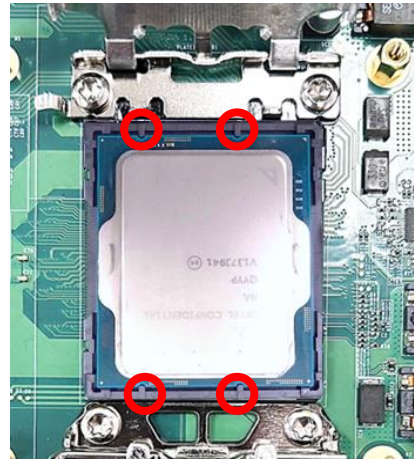
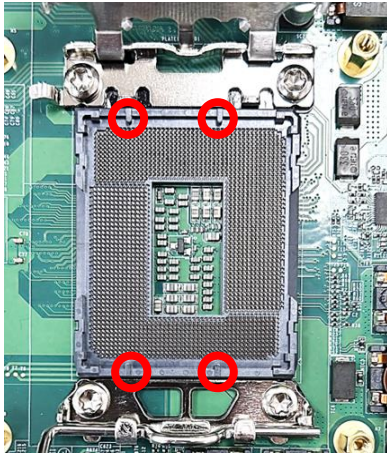

Step 6. Hold the end of the lead connected to the socket cover to press down the socket cover.



Step 7. Keep pressing the end of the lead and press down to lock the lever simultaneously. During this process, the cover will automatically pop up, as shown below.

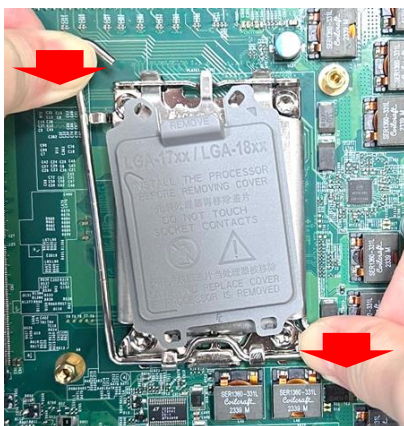

Step 8. Make sure that the CPU surface is clean, and apply the thermal paste (included in the CPU Installation Kit) onto the CPU's surface as shown below. For more detailed information about the thermal paste application, please find the [Intel official website](#).



Step 9. Aim at the four mounting holes and put on the CPU thermal block (included in the package). Then fasten two screws (M3x8L, Round Head, included in the screw pack) at the upper left and lower right corners as shown below. (Screws at upper right and lower left corners need not to fasten here, they will be fastened in the step 3 of Chapter 3.8.)

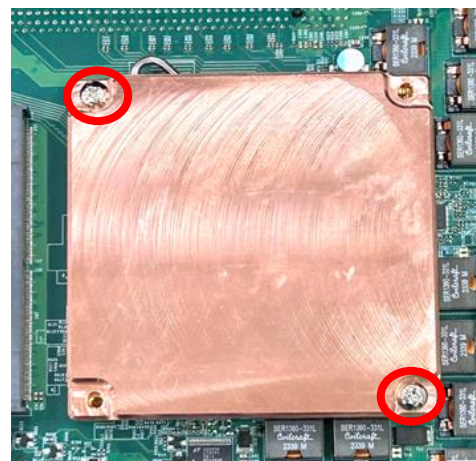

Step 10. Peel off the protective film from one side of the Thermal Pad (included in the package)..



Step 11. Place the thermal pad onto the CPU heatsink, ensuring the peeled side faces downward.

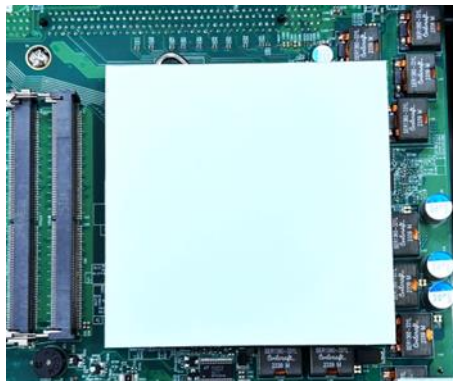

Step 12. Remove the transparent protective film from the other side of the Thermal Pad to complete the installation.



CAUTION
(ATTENTION)

Before assembling the system's chassis cover, please make sure the protective films on the Thermal Pad have been removed!

(Avant d'assembler le couvercle du châssis du système, assurez-vous que le film protecteur sur le coussin thermique a été retiré !)

3.3 Installing MOSFET Heatsink Thermal Pad

Step 1. As shown in the picture below, place thermal pad on the top of MOSFET heatsink in order to provide a seamless contact with the body of chassis to create an efficient heat dissipation.

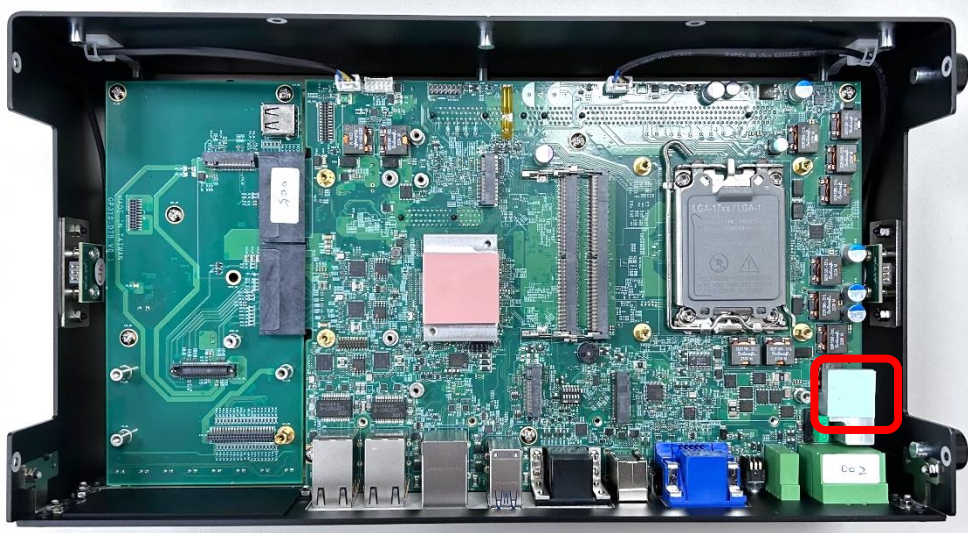

CAUTION
(ATTENTION)

Before assembling the system's chassis cover, please make sure the transparent protective film on the Thermal Pad has been removed!

(Avant d'assembler le couvercle du châssis du système, assurez-vous que le film protecteur transparent sur le pad thermique a été retiré !)

3.4 Installing SO-DIMM

Step 1. Locate the SODIMM socket.

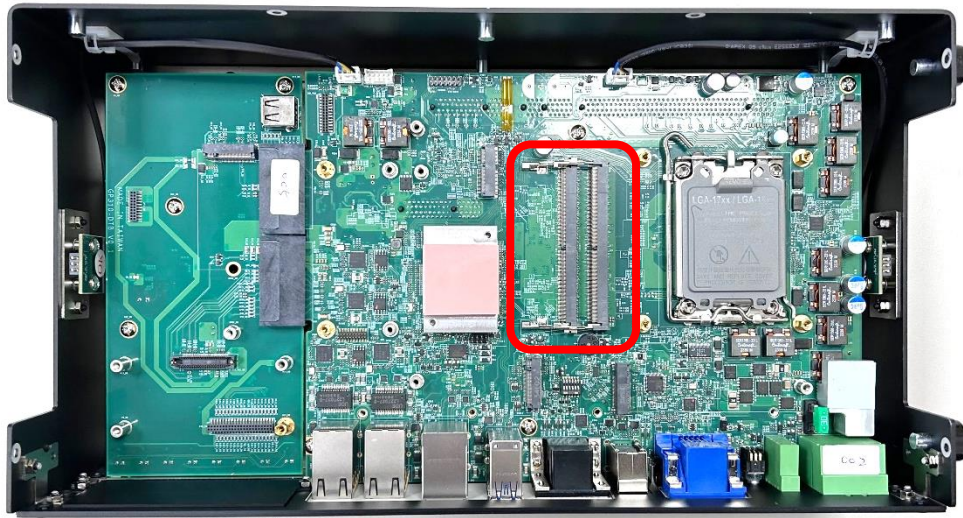

Step 2. Insert a SO-DIMM at a 45-degree angle until its golden fingers are fully connected to SO-DIMM socket firmly.



Lower socket



Upper socket

Step 3. Press down the module until the retaining clips snap back in place.

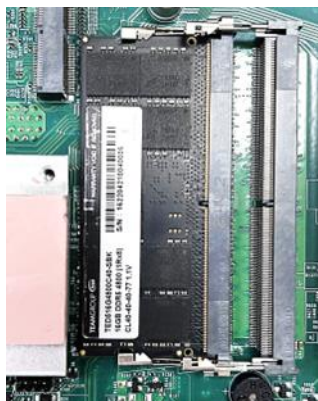

Lower socket



Upper socket

3.5 Installing M.2 Key B Module

3.5.1 M.2 Key B 2280 Socket

Step 1. Locate the M.2 Key B socket (CN1_DB) on the GP-310 DTB.

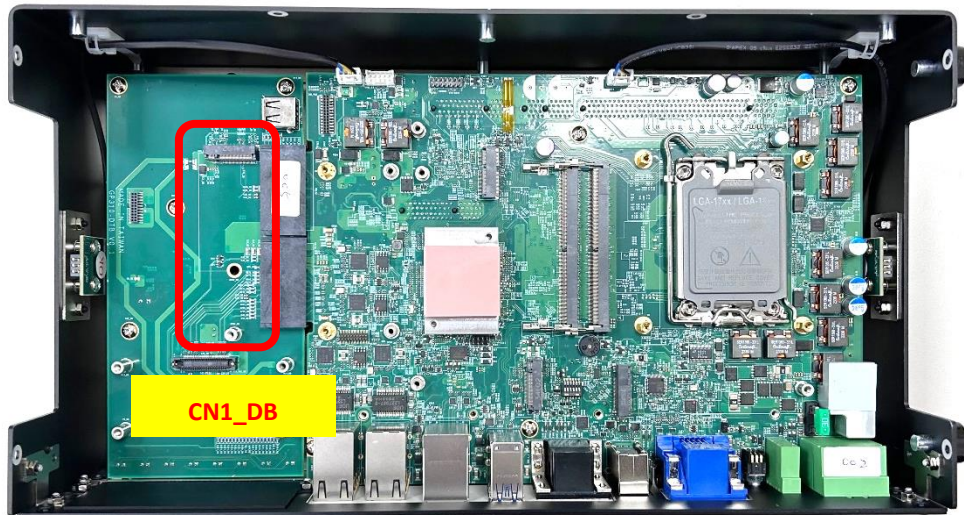

Step 2. Insert the M.2 Key B type 2280 module at a 45-degree angle and insert it to the slot until the gold-pated connector of module contacted firmly with the slot.

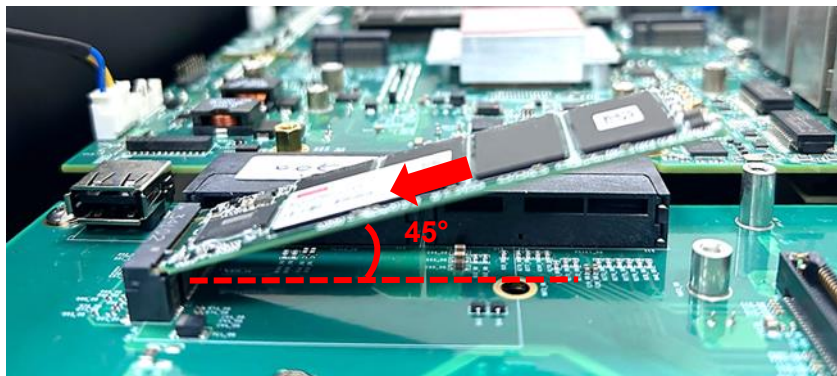

Step 3. Press down the module and fasten the screw to secure the module. (M3X5L, included in the Screw Pack).



3.5.2 M.2 Key B 3052 Socket

3.5.2.1 M.2 Key B 3052 Module

Step 1. Locate the M.2 Key B socket (CN4) on the system motherboard.

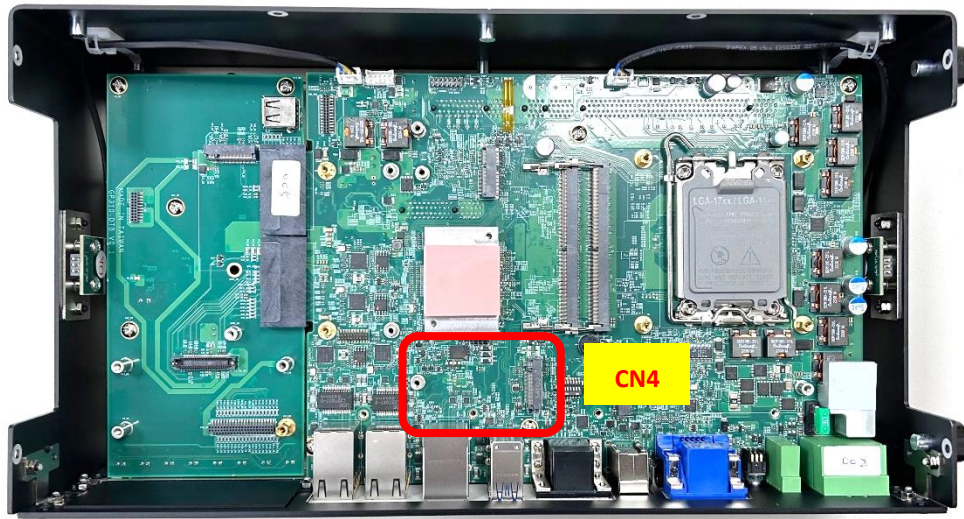

Step 2. Insert the M.2 Key B type 3052 module at a 45-degree angle and insert it to the slot until the gold-pated connector of module contacted firmly with the slot.

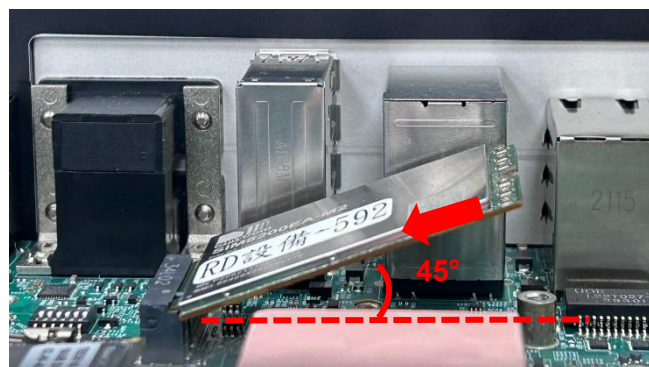

Step 3. Press down the module and fasten the screw to secure the module. (M3x5L, included in the Screw Pack).



3.5.2.2 M.2 Key B 2242/3042 Module

This section uses an M.2 Key B 2242 module as an example to demonstrate the installation.

Step 1. Locate the M.2 Key B socket (CN4) on the system motherboard.

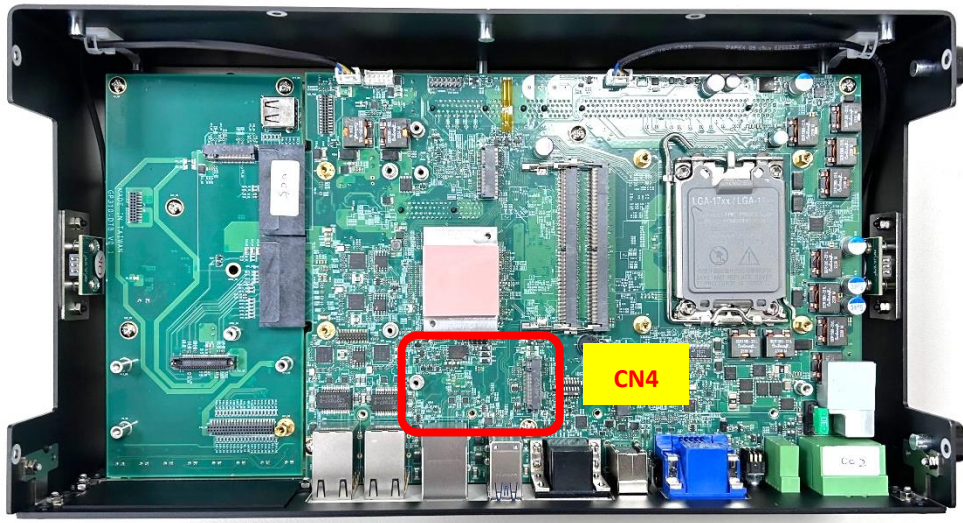

Step 2. Align the M.2 Key B Type 3052 to 3042 Adapter Bracket (included in the Package) with the corresponding screw hole. Secure the bracket in place and fasten the screw (M3x4L, included in the Screw Pack).

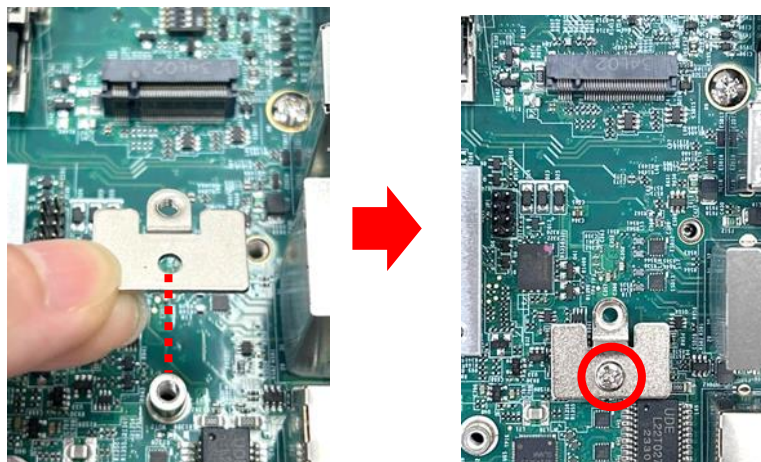

Step 3. Insert the M.2 Key B module at a 45-degree angle and insert it to the slot until the gold-pated connector of module contacted firmly with the slot.



Step 4. Press down the module and fasten the screw to secure the module. (M3x5L, included in the Screw Pack).

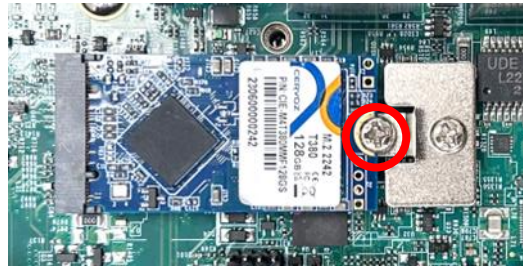

3.6 Installing M.2 Key E Module

Step 1. Locate the M.2 Key E socket (CN5) on the system motherboard.

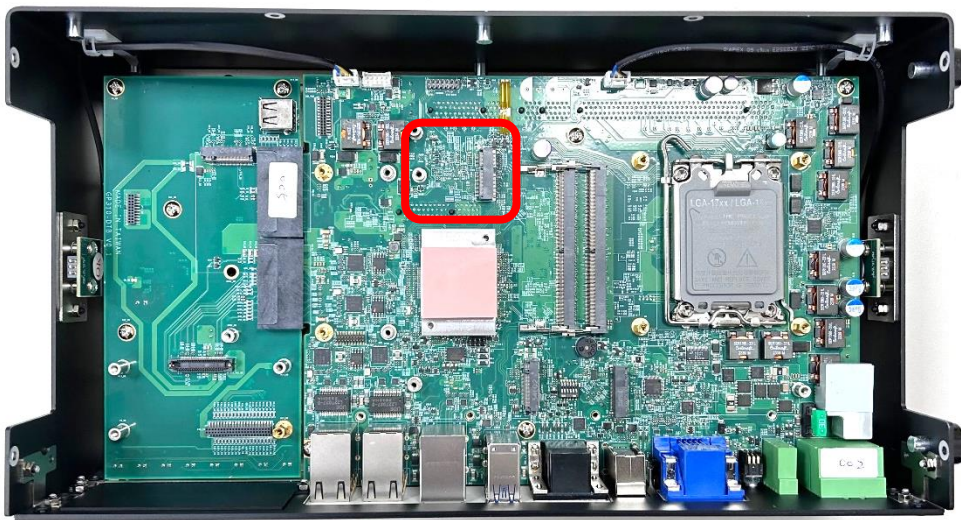

Step 2. Tilt the M.2 Key E module at a 45-degree angle and insert it to the socket until the golden finger connector of the card seated firmly.



Step 3. Press the module down and secure it with the screw (M3x5L, included in the Screw Pack).



3.7 Installing M.2 Key M Module

Step 1. Locate the M.2 Key M socket (CN6) on the system motherboard.

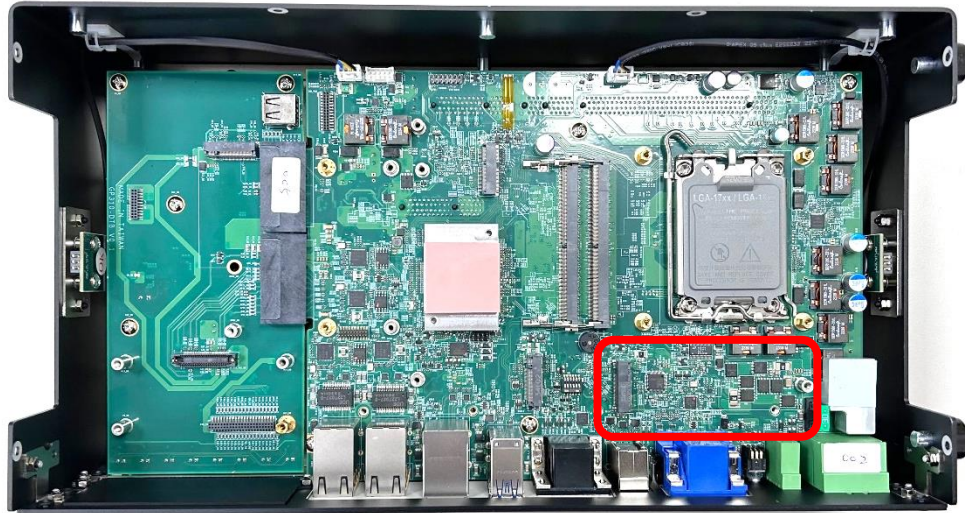

Step 2. Tilt the M.2 Key M module at a 45-degree angle and insert it to the socket until the golden finger connector of the card seated firmly.

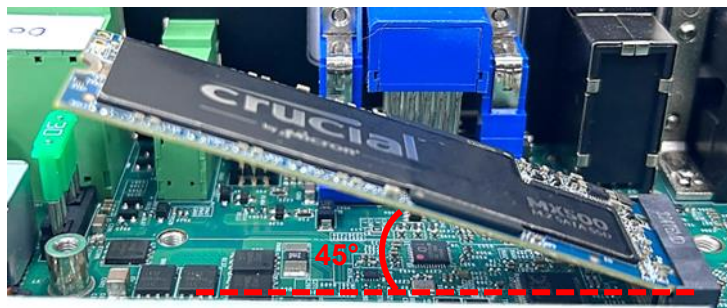

Step 3. Press the module down and secure it with the screw (M3x5L, included in the Screw Pack).



3.8 Installing Antenna(s)

3.8.1 Antenna #1 to #4

Step 1. Remove the antenna rubber cover on the rear panel.



Step 2. Penetrate the antenna jack through the hole.



Step 3. Put on the washers and fasten the nut of antenna jack.



Step 4. Assemble the antenna and antenna jack together.



Step 5. Remember to attach the RF connector of the cable's another end onto the wireless card after wireless card's installation.



3.8.2 Antenna #5 to #7

Step 1. Remove the antenna rubber cover on the rear panel.



Step 2. Grip the antenna jack with a tweezer and then penetrate it through the hole as indicated.

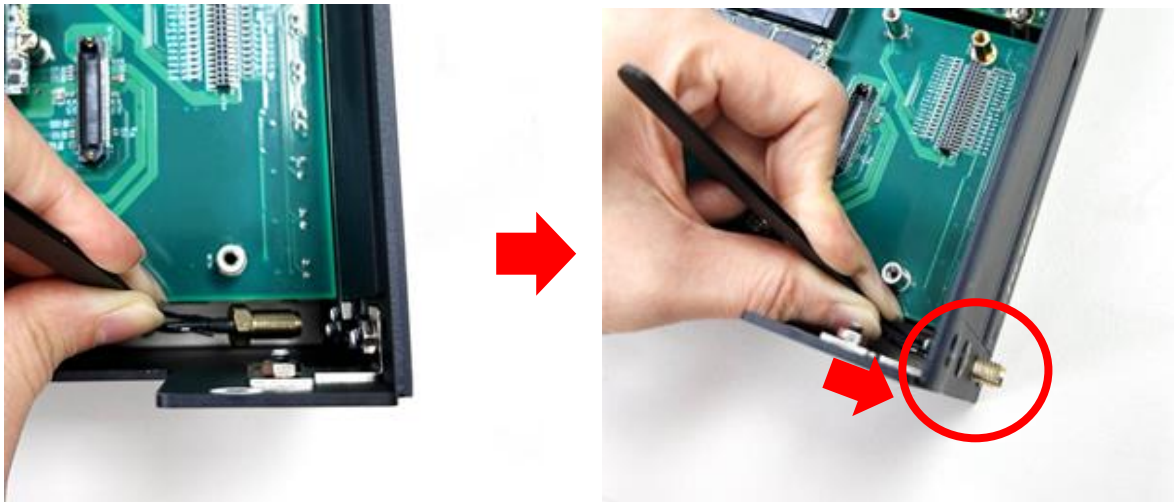

Step 3. Put on the washers and fasten the nut of antenna jack.



Step 4. Assemble the antenna and antenna jack together.



Step 5. Remember to attach the RF connector of the cable's another end onto the wireless card after wireless card's installation.



3.9 Installing Top Cover

Step 1. Put the top cover back onto the chassis.



Step 2. Fasten the 6 screws back on the left, right, and rear panels of the system.



Left Panel

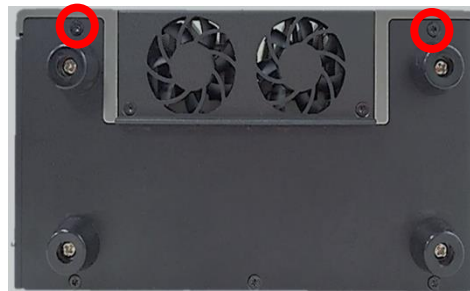

Right Panel

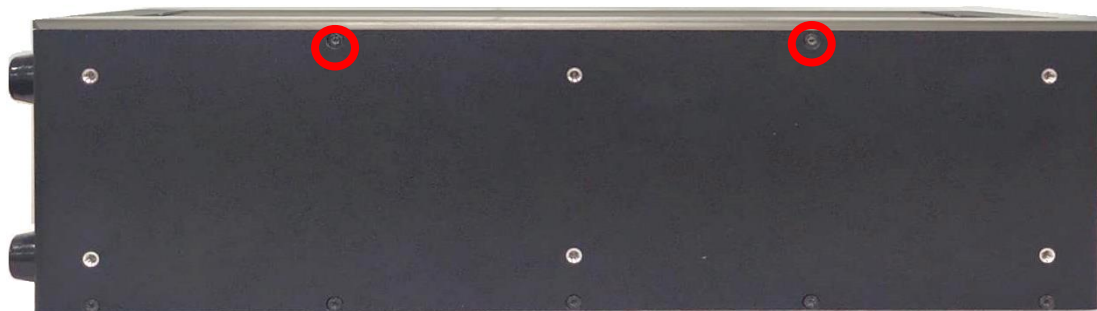

Rear Panel

Step 3. Fasten the 2 screws on the top cover.



Step 4. Put on the top plate, and fasten the 4 screws to fix the top plate.

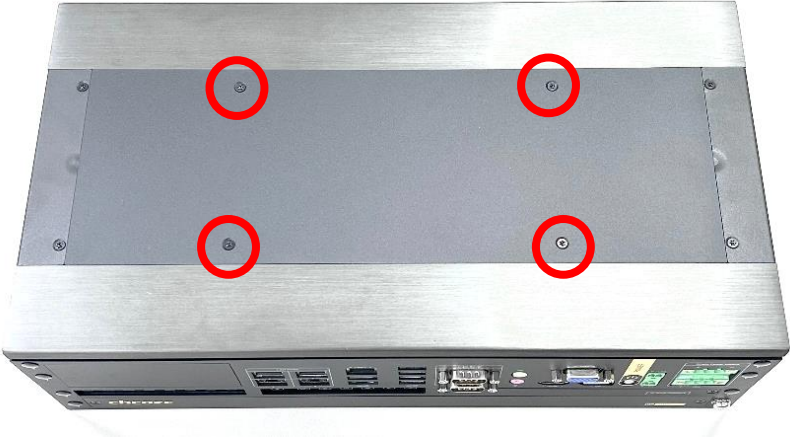

3.10 Installing SATA Hard Drives at Front Panel

Step 1. Loosen the two screws to remove the front cover plate.



Step 2. Loosen the indicated screw(s) to remove the HDD bay cover bracket.



Step 3. Pull the rotating arm and pull the HDD bracket out of system.



Step 4. Make HDD bottom side face up, place the HDD bracket on it. Ensure the direction of bracket is correct and use 4 provided screws (M3x4L, included in the Screw Pack) to assemble HDD and HDD bracket together.

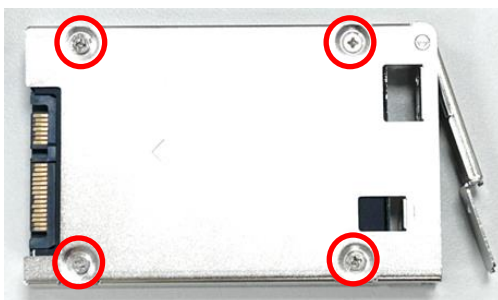

Step 5. Align the HDD bracket with the entrance of HDD bay. Insert the HDD bracket and push it until the HDD connector is fully inserted into the SATA slot.



Step 6. Place the rotating arm back and fasten the screw(s).

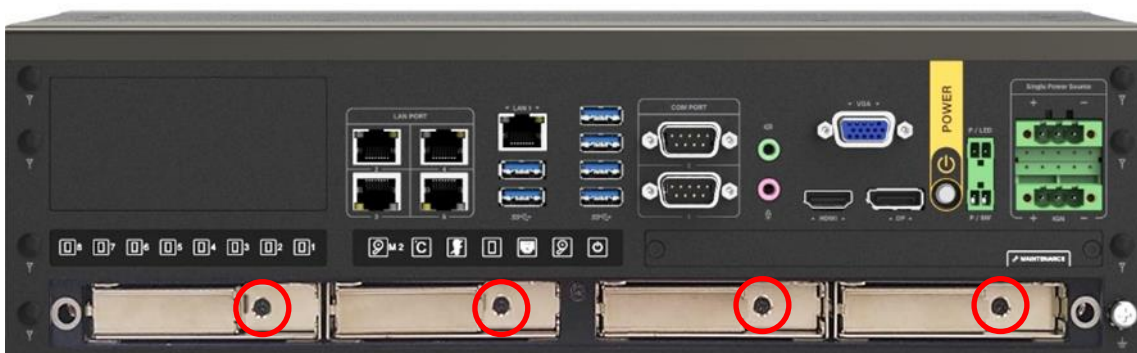

Step 7. Fix the cover by fastening the two screws back.



3.11 Installing SIM Card

Please install a 5G/4G module before the SIM card installation for the SIM application.

Step 1. Loosen the two screws to remove the cover plate of maintenance zone.



Step 2. Locate the SIM card slot at front side and insert a SIM card into a SIM slot with the gold contacts facing down. Please pay attention to the insert orientation as illustrated. (Please note when both SIM cards are installed, the network connection will prioritize the card at SIM1).



Step 3. Fix the cover plate of maintenance zone by fastening the two screws back.

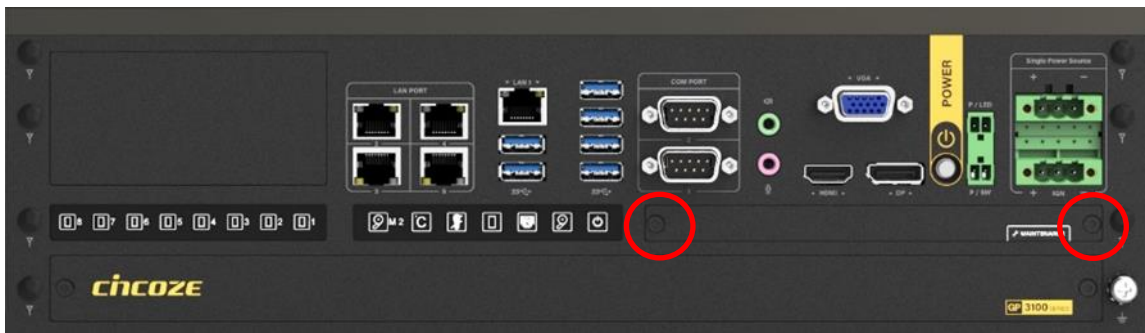

3.12 Installing Rubber Foot Pad

If you require Desktop Mounting for GP-3100, please refer to Chapter 3.14 and skip this chapter.

Step 1. Locate the four screw holes on the side panel.

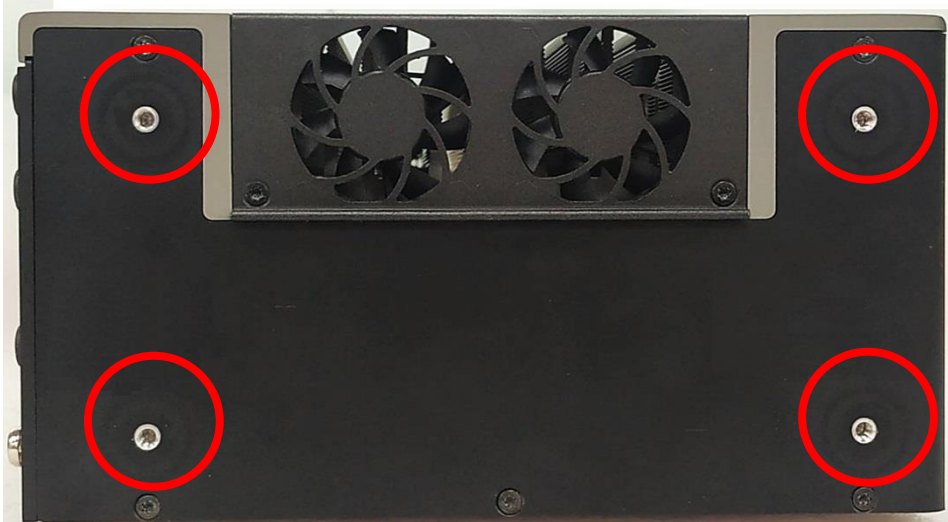

Step 2. Attach on the four rubber foot pads and fasten the four screws (M4x8L) to fix them.

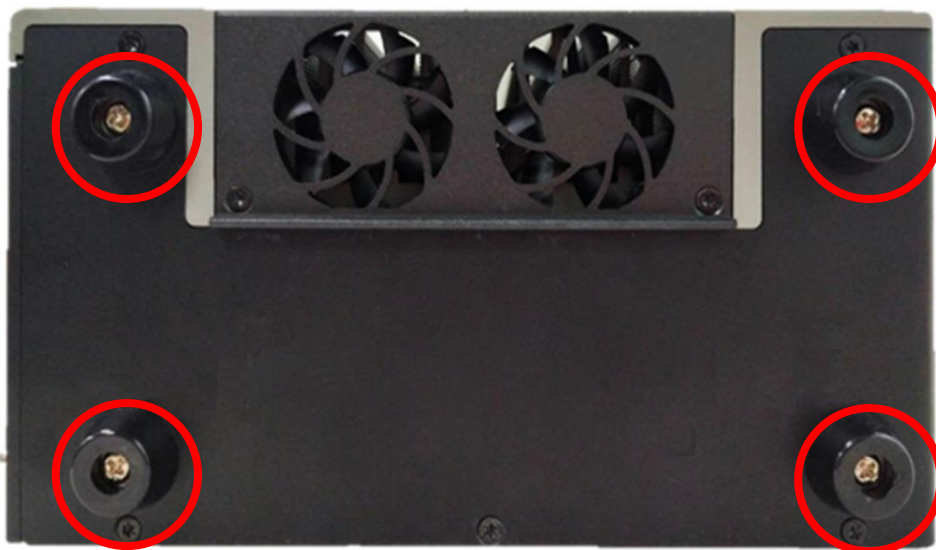

3.13 Installing Wall Mount

GP-3100 series offers wall mount kit that customers can install system on the wall in a convenient and economical way.



Step 1. Attach the wall mount bracket onto the system according to the orientation shown below.



Step 2. Use provided 6 screws (M4x8L) to fasten the bracket.



Step 3. The 4 bracket mounting holes are used to fix the system on the wall.



3.14 Installing Desktop Mount Bracket

GP-3100 series offers Desktop Mount Kit that customers can easily and economically install system on some plane surfaces on-site.



Step 1. Locate the screw holes on the bottom side of the system.

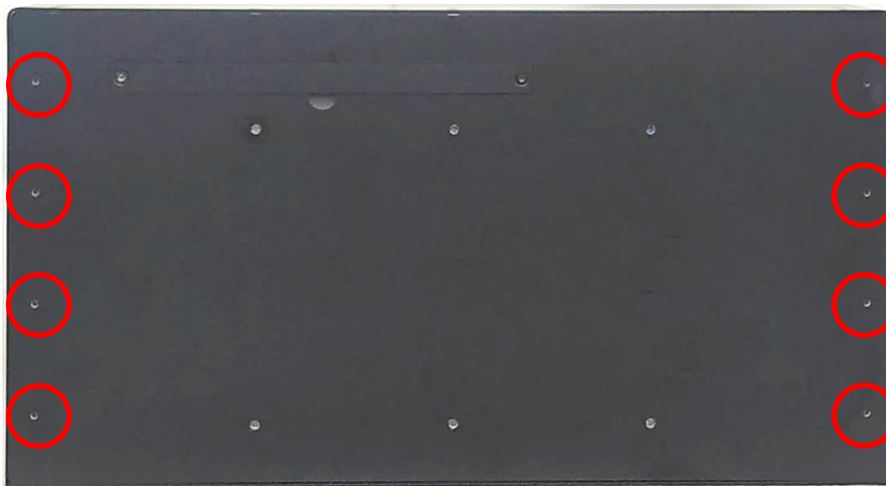

Step 2. Attach the Desktop Mount Bracket and then fasten the 8 screws (M3x5L).

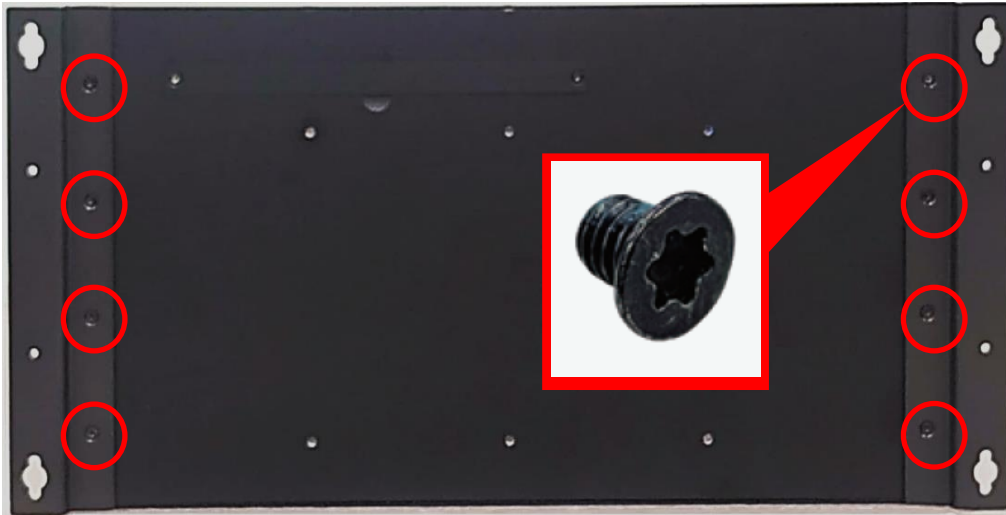

Step 3. Attach on the four rubber foot pads and fasten the four screws to fix them at the bottom side.

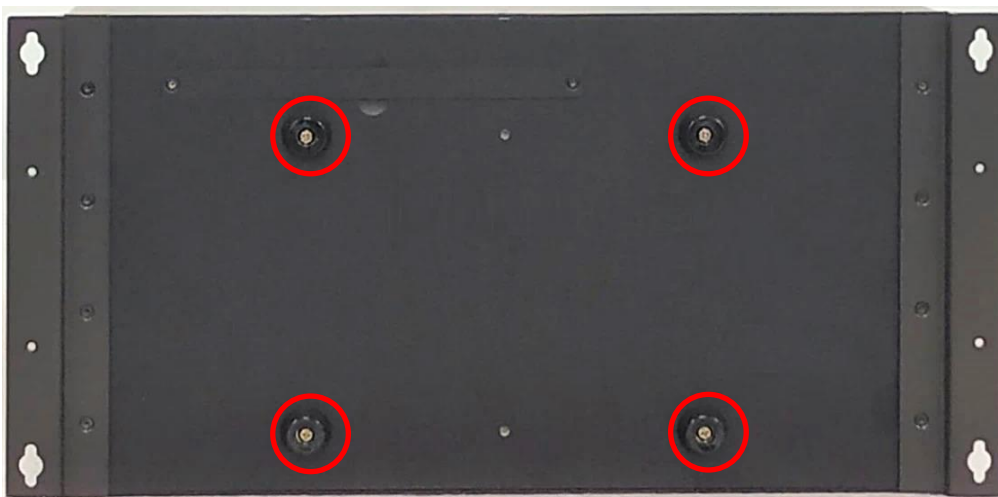

3.15 Installing 19" Rack Mount

GP-3100 provides 19" Rack Mount kit that customers can install the system onto the 19" Rack. There are two methods to install the system onto the 19" Rack, which are Method A and Method B as illustrated below.



Before installing GP-3100 onto the 19" Rack Mount, please follow the steps below to assemble the 19" Rack Mount kit first.

- (1) Locate the four screw holes



- (2) Attach the two handles onto the seat bracket, and fasten the four screws (M5x12L) to fix them from the back side.

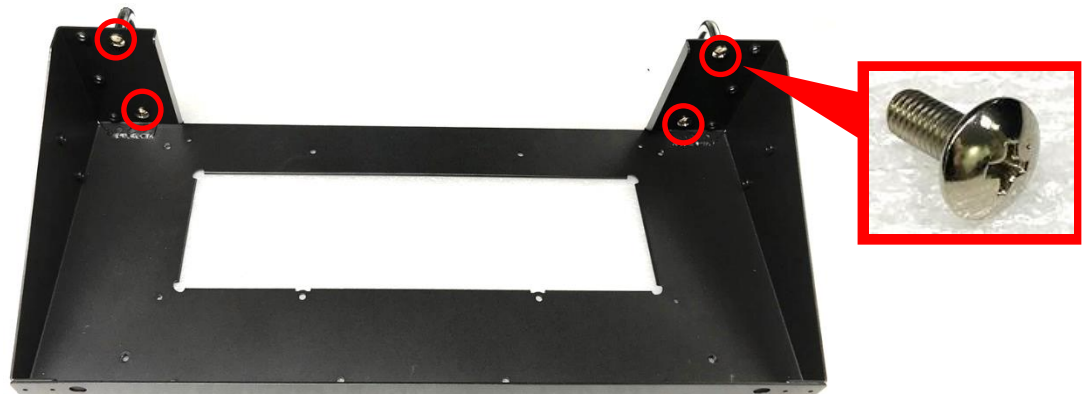

Method A

Step 1. Place the GP-3100 into the assembled 19" Rack Mount kit.



Step 2. Turn to the bottom side of the 19" Rack Mount kit, and fasten the four screws (M4x5L).

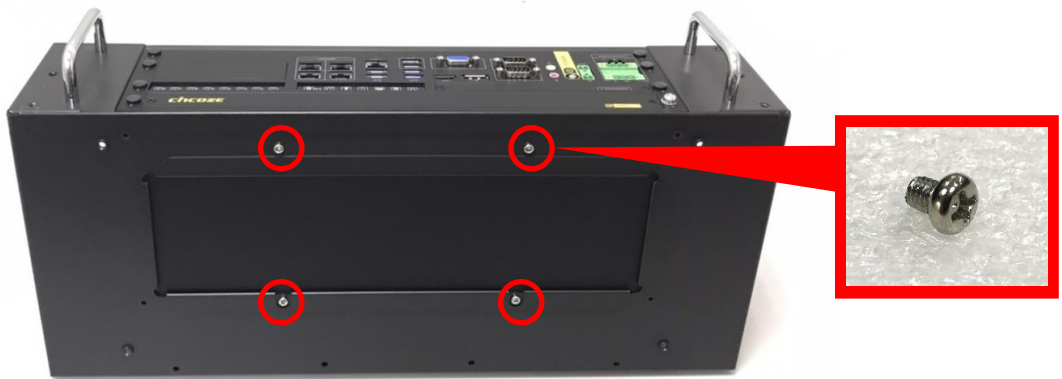

Method B

Step 1. Get ready the GP-3100 installed with the desk mount according to Chapter 3.14. Place the GP-3100 with the desktop mount into the assembled 19" Rack Mount kit.



Step 2. Fasten the four screws (M5x12L) through the desk mount holes.



After complete the Method A or Method B steps, install the GP-3100 with the 19" Rack Mount kit onto the 19" Rack by fastening 4 screws to complete the installation. (User needs to prepare the screws according to the rack on site)



3.16 Connecting to Power Supply

Step 1. Locate the DC_IN1 power connector.



Step 2. Aim the V- wire (black wire) at the V- port, and aim the V+ wire (white wire) at the V+ port on the DC_IN connector. Then connect the phoenix contacts of the power supply to the DC_IN connector.



Step 3. Fasten the four screws to fix the phoenix contacts. (Please use new Phoenix contacts and make sure the screws are tightened to avoid poor connection.)

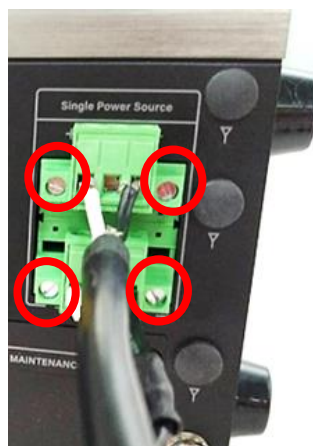

3.17 Installing High Speed CMI Module

3.17.1 CMI-LAN01/UB1812 Module

Step 1. Loosen the 2 hex nuts on the back side of the cover plate, and then remove the cover plate.

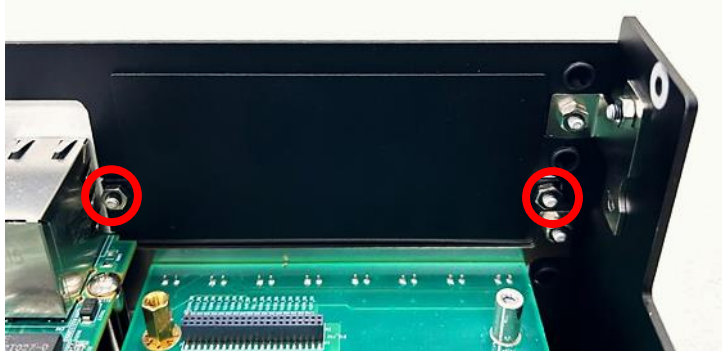

Step 2. Attach the CMI-LAN bracket, and fasten the 2 hex nuts back to fix it as indicated.

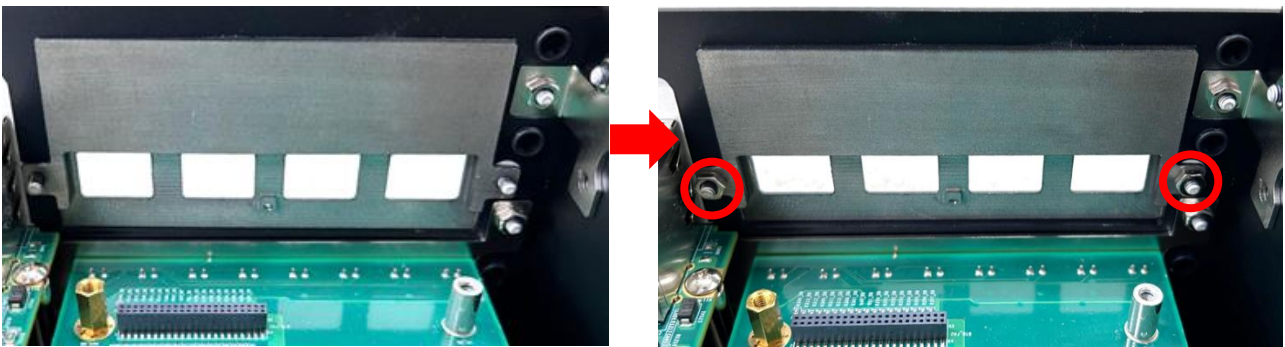

Step 3. Locate the connector BTB_FH1_DB on the GP-310 DTB.

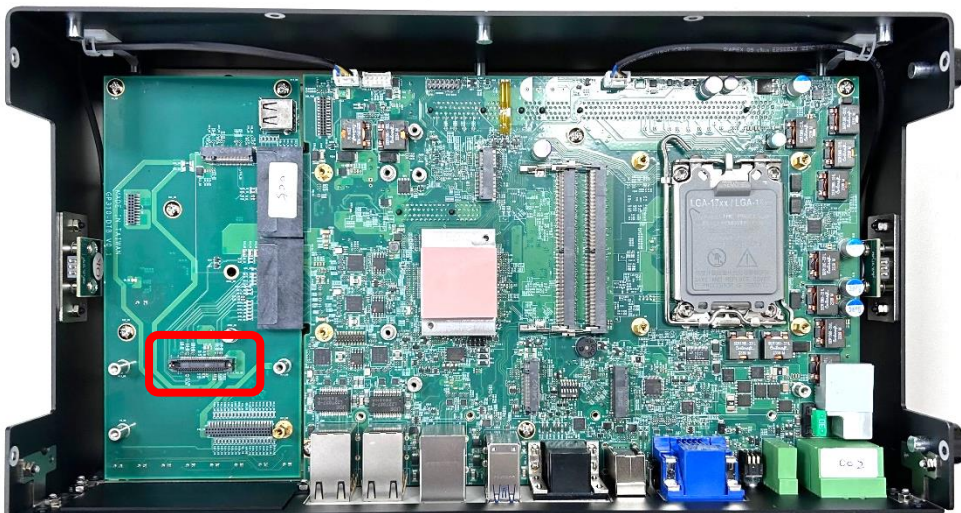

Step 4. Aim the module's LAN ports at the holes on the bracket with an inclined angle, push it slightly and insert it vertically to the connector BTB_FH1_DB.

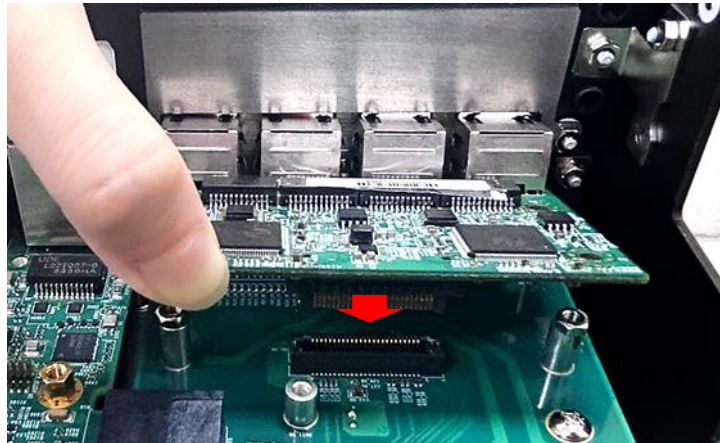

Step 5. Fix it with the four screws (M3x5L).

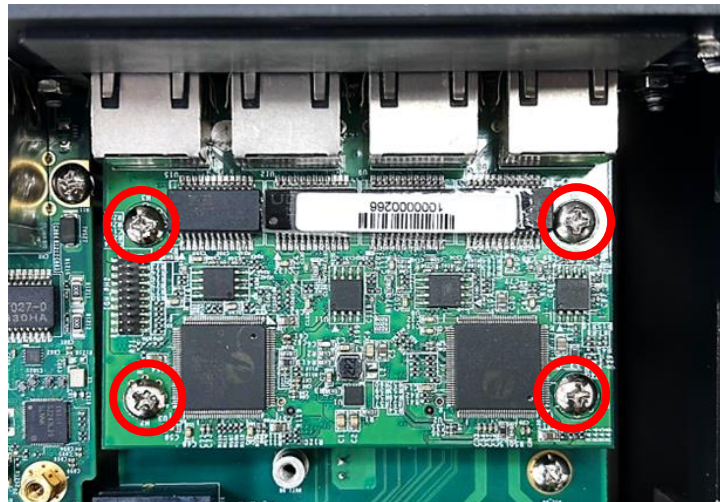

Step 6. Installation is then complete, as shown below.



3.17.2 CMI-M12LAN01/UB1810 Module

Step 1. Loosen the 2 hex nuts on the back side of the cover plate, and then remove the cover plate.

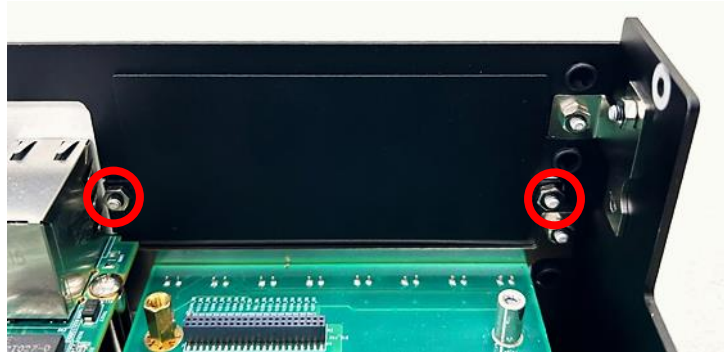

Step 2. Attach the CMI-M12LAN bracket, and fasten the 2 hex nuts back to fix it as indicated.

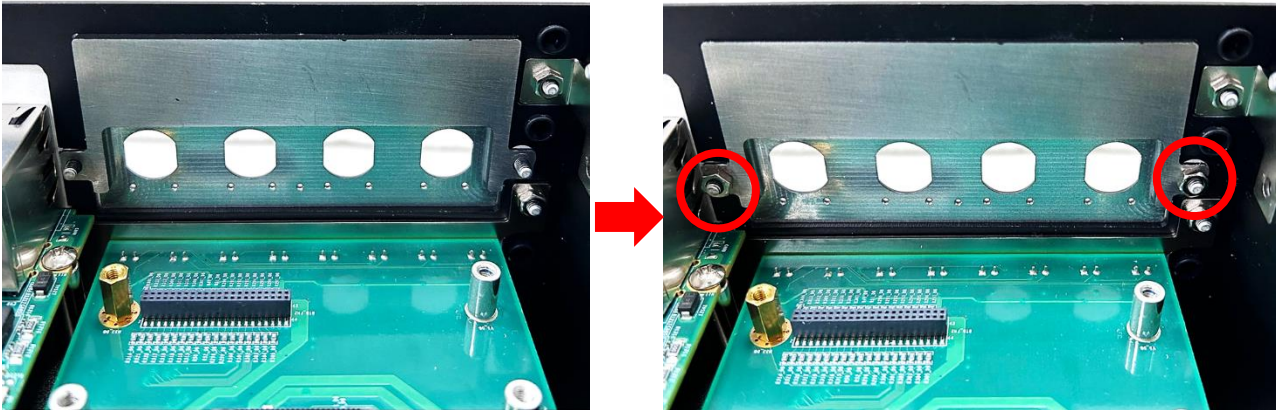

Step 3. Locate the connector BTB_FH1_DB on the GP-310 DTB.

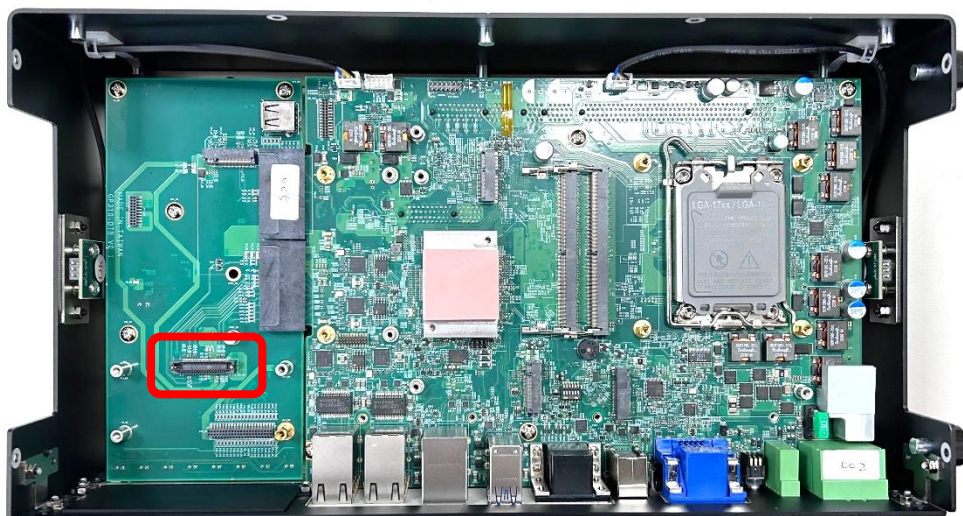

Step 4. Remove the four hex rings from the CMI-M12LAN module.



Step 5. Penetrate the CMI-M12LAN ports through the holes on the bracket.



Step 6. Push the CMI-M12LAN module slightly and insert it vertically into the connector BTB_FH1_DB.



Step 7. Fix it with the four screws (M3x5L).



Step 8. Put back and fasten the four hex rings to fix the cover plate.

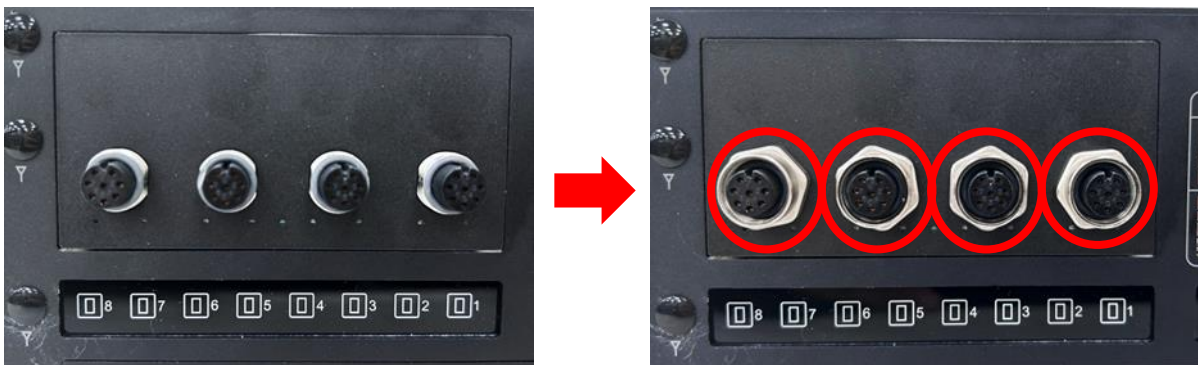

3.17.3 CMI-XM12LAN01/UB1830 Module



Step 1. Assemble the hex rings, M12 I/O bracket, hex washers together as indicated below:
Penetrate hex rings through the M12 I/O bracket holes, and fix them with hex washers.



Step 2. Loosen the 2 hex nuts on the back side of the cover plate, and then remove the cover plate.



Step 3. Attach the assembled M12 I/O bracket on to the system, and fasten the two hex nuts back to fix it.

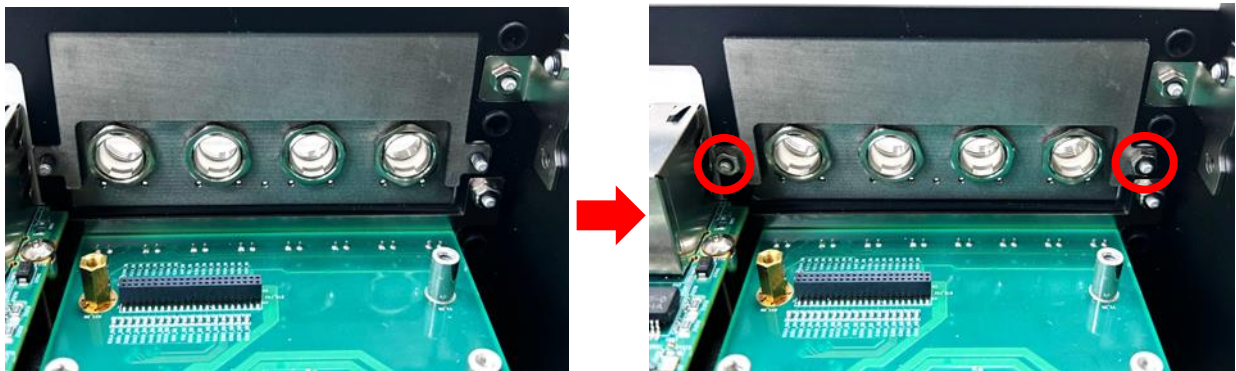

Step 4. Locate the connector BTB_FH1_DB on the GP-310 DTB.

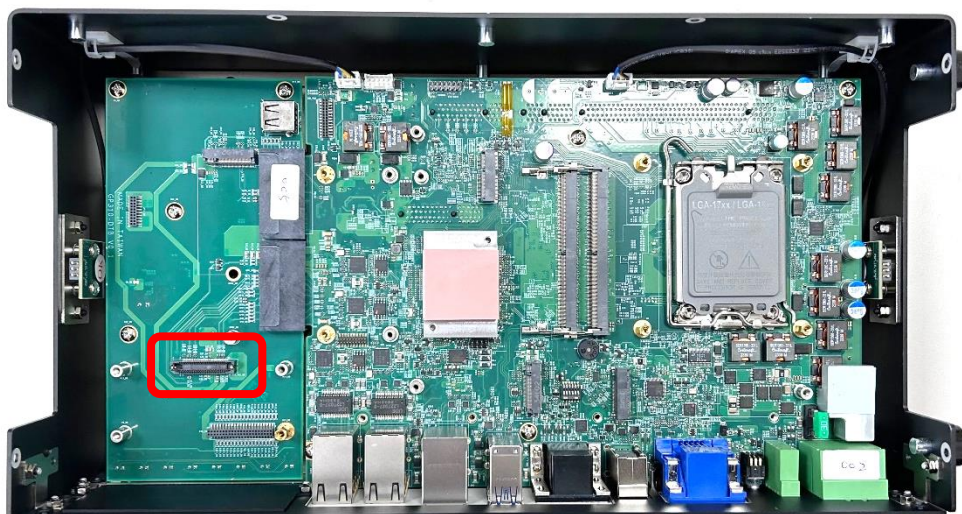

Step 5. Penetrate the CMI-XM12LAN ports through the holes on the bracket.

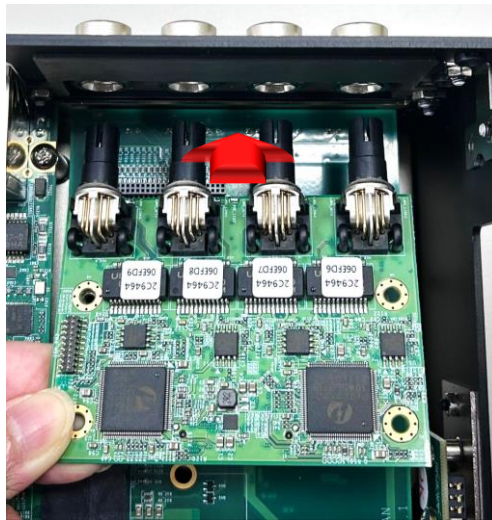

Step 6. Push the CMI-XM12LAN module slightly and insert it vertically into the connector BTB_FH1_DB.

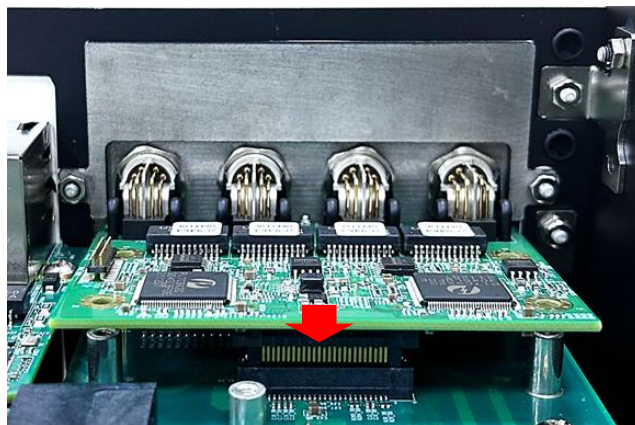

Step 7. Fix it with the four screws (M3x5L).

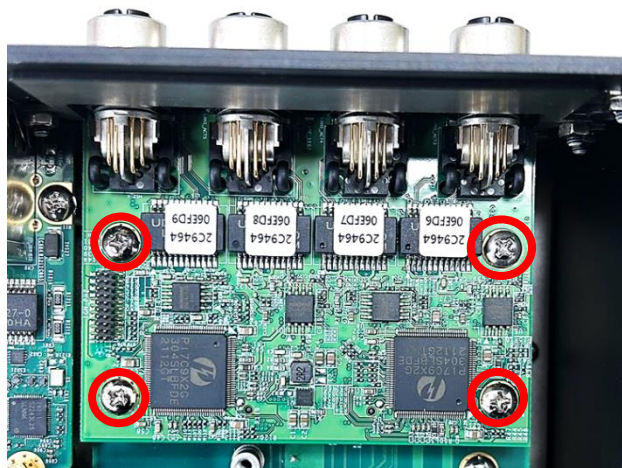

Step 8. Put on and push the rubber rings until they touch the four M12 LAN ports.



Step 9. Installation is then complete, as shown below.



3.17.4 CMI-10GLAN02/UB1828 Module

Before installing the CMI-10GLAN02/UB1428 module, enter BIOS and navigate to **Chipset > PCH-IO Configuration**, then change the **[BTB_FH1_DB Mode Selection]** setting from **[4x1]** (default) to **[1x4]**.

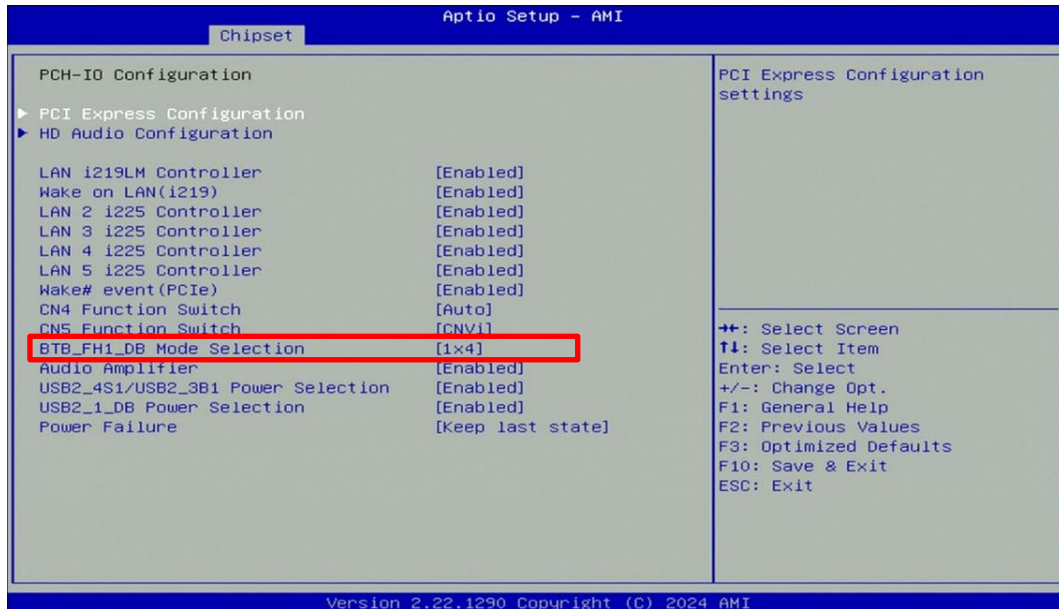

Step 1. Loosen the 2 hex nuts on the back side of the cover plate, and then remove the cover plate.



Step 2. Attach the CMI-10GLAN bracket, and fasten the 2 hex nuts to fix it as indicated.

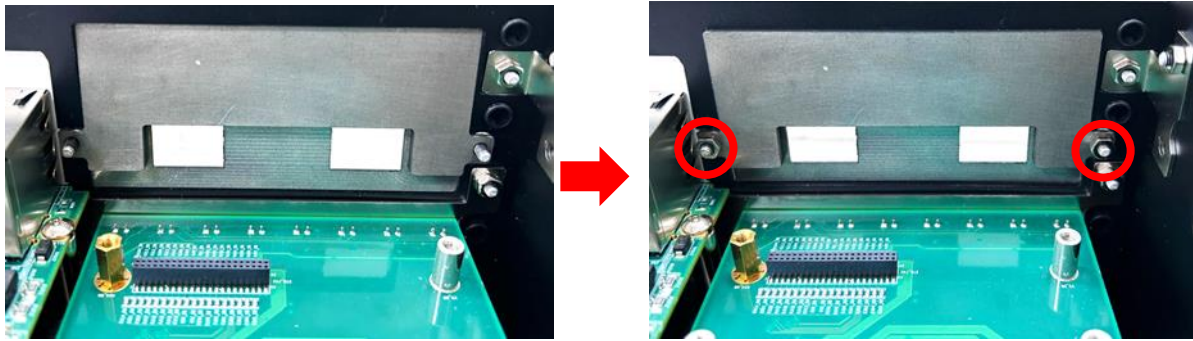

Step 3. Locate the connector BTB_FH1_DB on the GP-310 DTB.

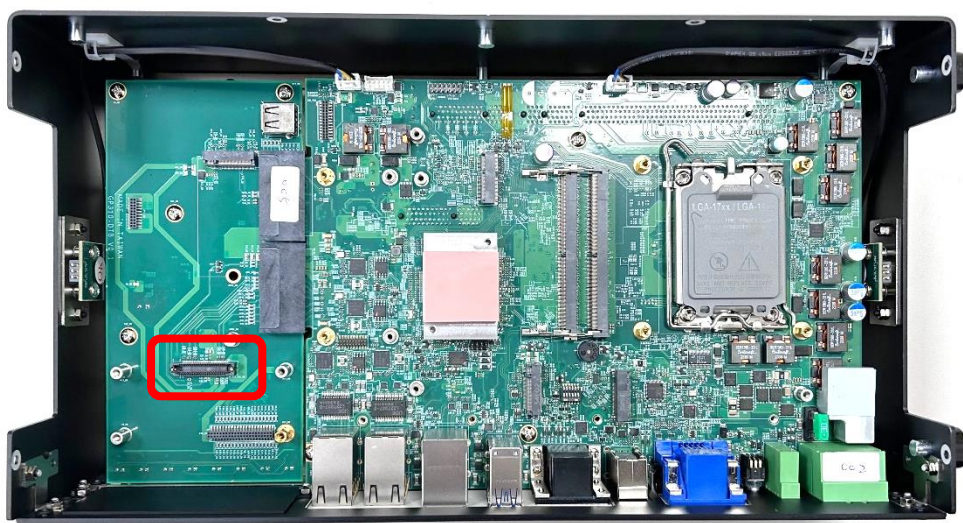

Step 4. Locate the chip place on the CMI-10GLAN module marked by red square. Paste the thermal pad on it carefully.

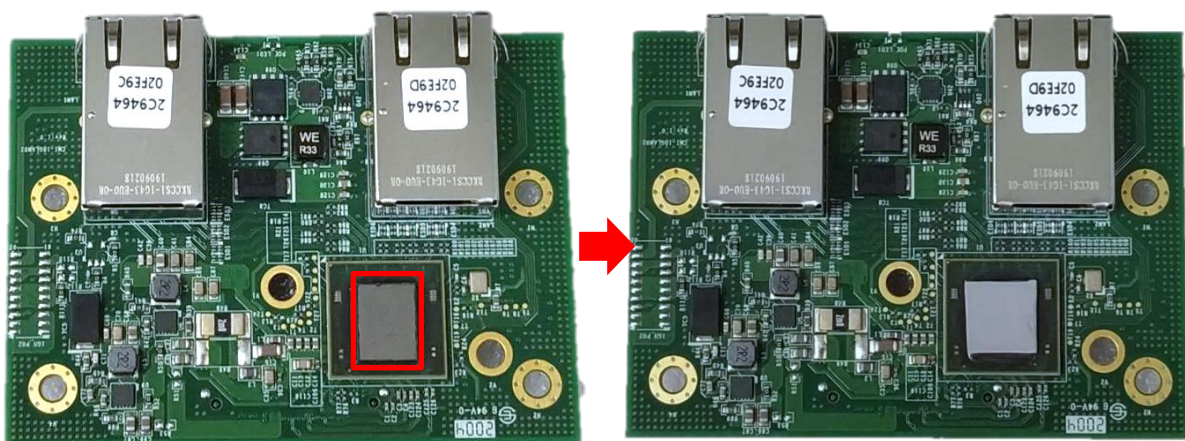

CAUTION
(ATTENTION)

Before putting on the heatsink (in the next step), please make sure the transparent protective film on the Thermal Pad has been removed!

(Avant de placer le dissipateur thermique (à l'étape suivante), veuillez vous assurer que le film protecteur transparent sur le pad thermique a été retiré !)

Step 5. Put on the heatsink and turn over the module. Fasten the screw (M3x5L) to fix the heatsink.

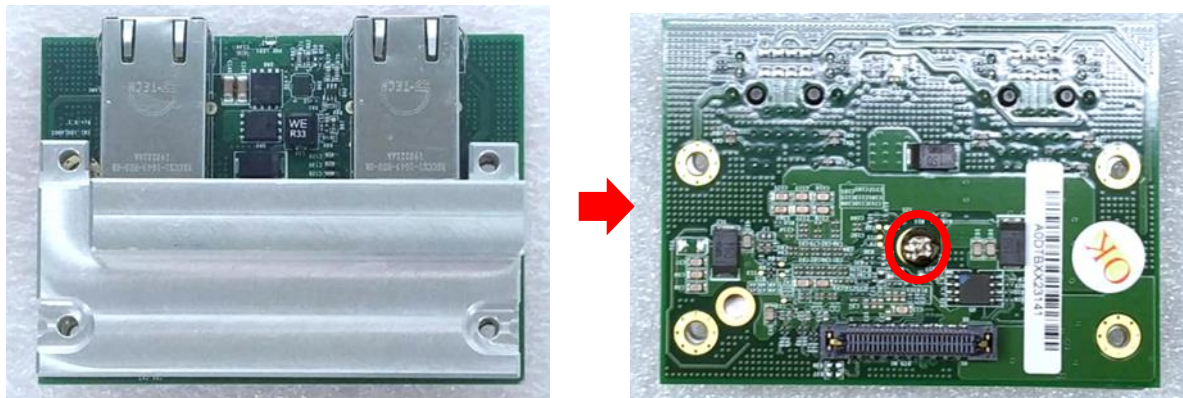

Step 6. Aim the module's LAN ports at the holes on the bracket with an inclined angle, push it slightly and insert it vertically to the connector BTB_FH1_DB.

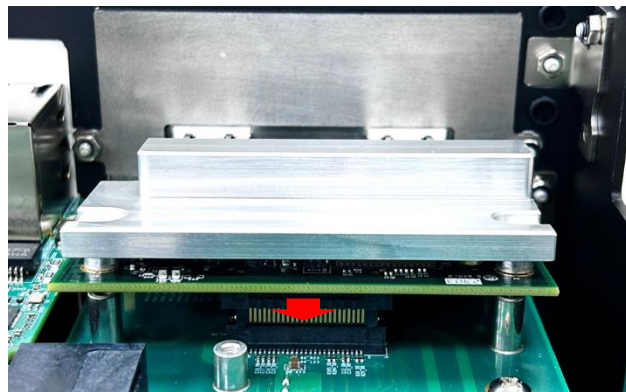

Step 7. Fasten the 4 screws (M3x12L) to fix it.

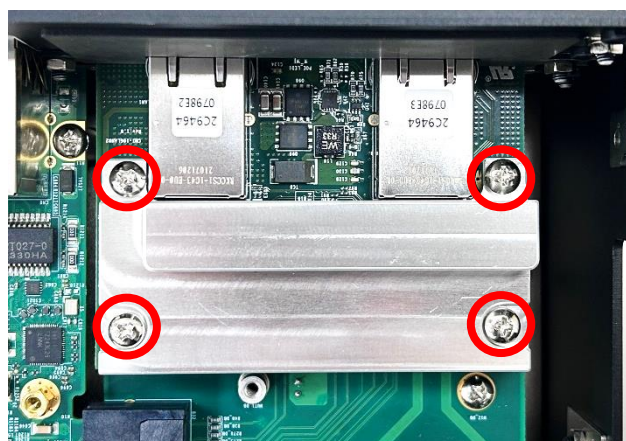

Step 8. Peel off the protection film on the thermal pad.

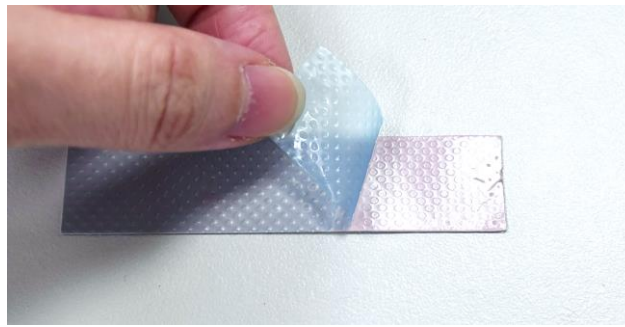

Step 9. Paste the two thermal pads onto the heatsink carefully.

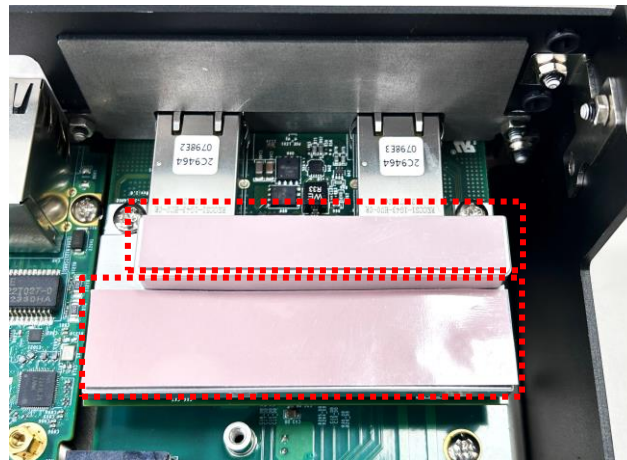

CAUTION
(ATTENTION)

Before assembling the system's chassis cover, please make sure the transparent protective films on the Thermal Pads have been removed!

(Avant d'assembler le couvercle du châssis du système, veuillez vous assurer que les films protecteurs transparents sur les pads thermiques ont été retirés !)

3.17.5 CMI-2P5GLAN02/UB1812 Module

Step 1. Loosen the 2 hex nuts on the back side of the cover plate, then remove the cover plate.

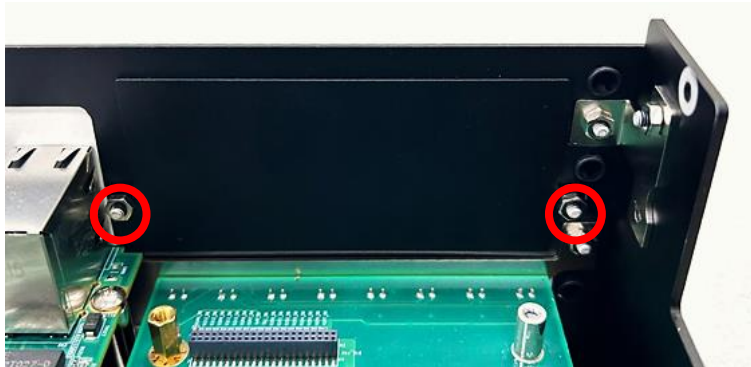

Step 2. Attach the CMI-LAN bracket, and fasten the 2 hex nuts to secure it as indicated.

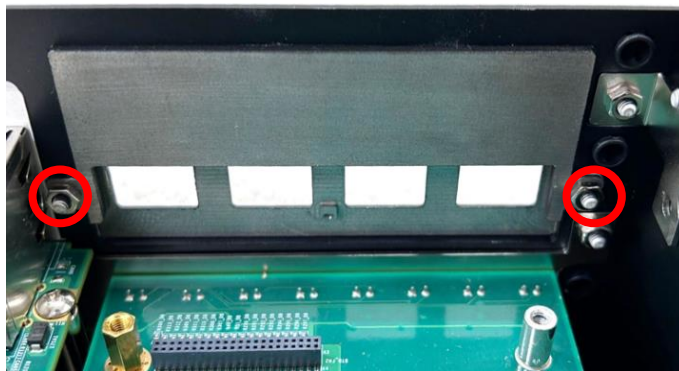

Step 3. Locate the 5 chips on the CMI-2P5GLAN module indicated by the red squares below. Carefully apply thermal pads to each chip.

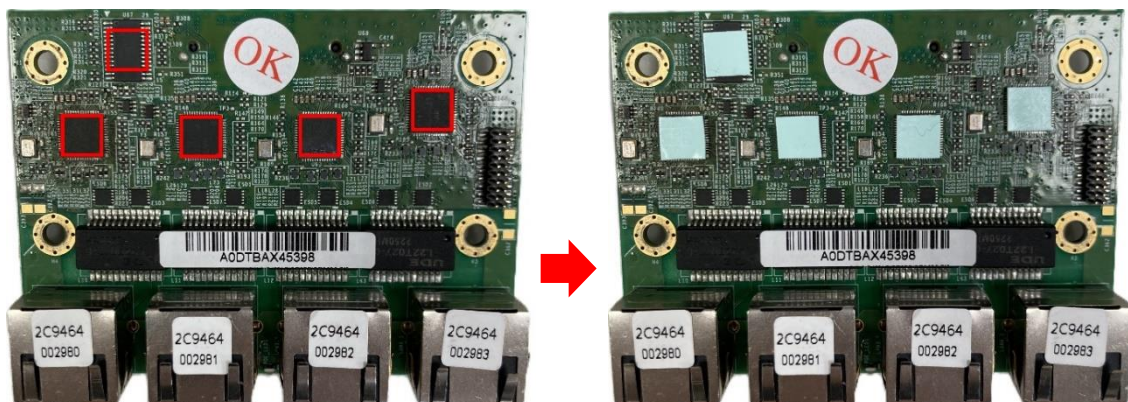

Step 4. Locate the connector BTB_FH1_DB on the GP-310 DTB.

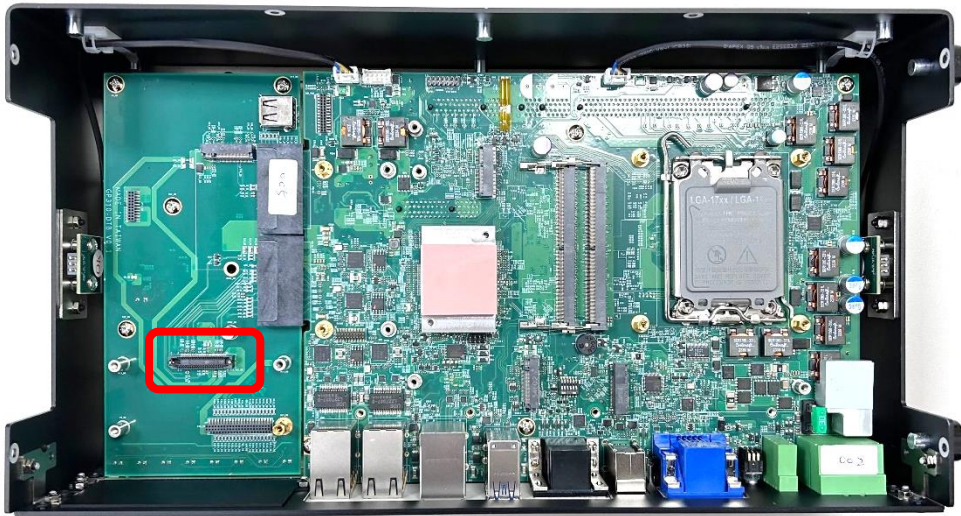

Step 4. Align the LAN ports of the module with the holes on the bracket at an angle. Press the module towards the bracket, then insert it vertically into the connector.

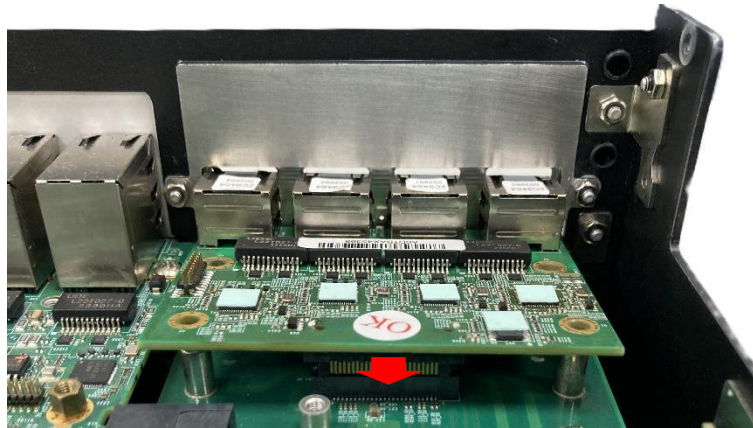

Step 5. Align the heatsink protrusions with the chip pads on the CMI module and place it onto the module.

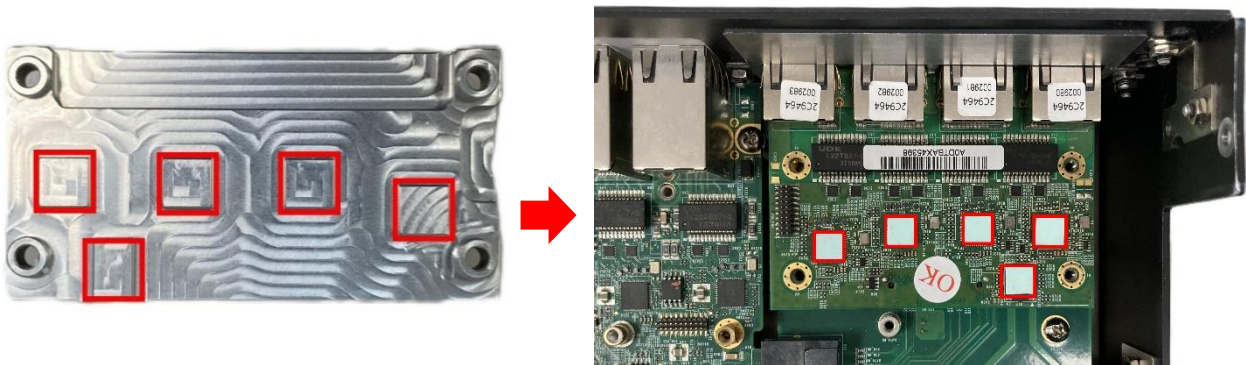



**CAUTION
(ATTENTION)**

Before putting on the heatsink (in the next step), please make sure the transparent protective film on the Thermal Pad has been removed!
(Avant de placer le dissipateur thermique (à l'étape suivante), veuillez vous assurer que le film protecteur transparent sur le pad thermique a été retiré !)

Step 6. Secure the CMI module using 4 screws (M3x12L) as indicated below.

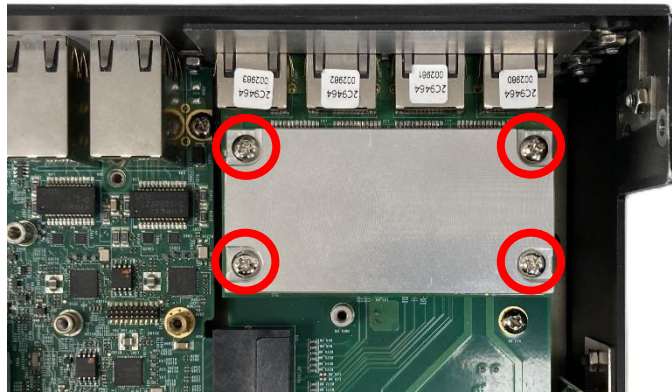

Step 7. Carefully apply a thermal pad to the heatsink.



**CAUTION
(ATTENTION)**

Before assembling the system's chassis cover, please make sure the transparent protective films on the Thermal Pads have been removed!
(Avant d'assembler le couvercle du châssis du système, veuillez vous assurer que les films protecteurs transparents sur les pads thermiques ont été retirés !)

3.17.6 CMI-10GXM12LAN02/UB1837 Module

Before installing the CMI-10GXM12LAN02/ UB1837 module, enter BIOS and navigate to **Chipset > PCH-IO Configuration**, then change the **[BTB_FH1_DB Mode Selection]** setting from **[4x1]** (default) to **[1x4]**.



Step 1. Assemble the 10GXM12LAN bracket as indicated below: slot the hex rings through the XM12 I/O bracket and secure them from the inside with the hex nuts.



Step 2. Loosen the 2 hex nuts on the back side of the cover plate, then remove the cover plate.

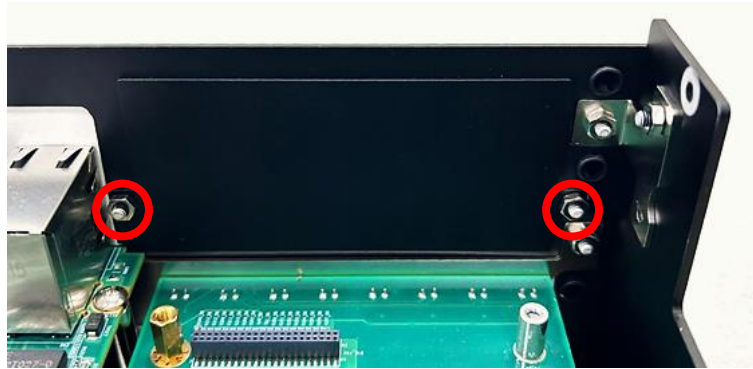

Step 3. Attach the CMI-10GXM12LAN bracket, and fasten the 2 hex nuts to secure it as indicated.



Step 4. Locate the chip on the 10GXM12LAN module indicated by the red square below. Carefully apply a thermal pad to the chip.

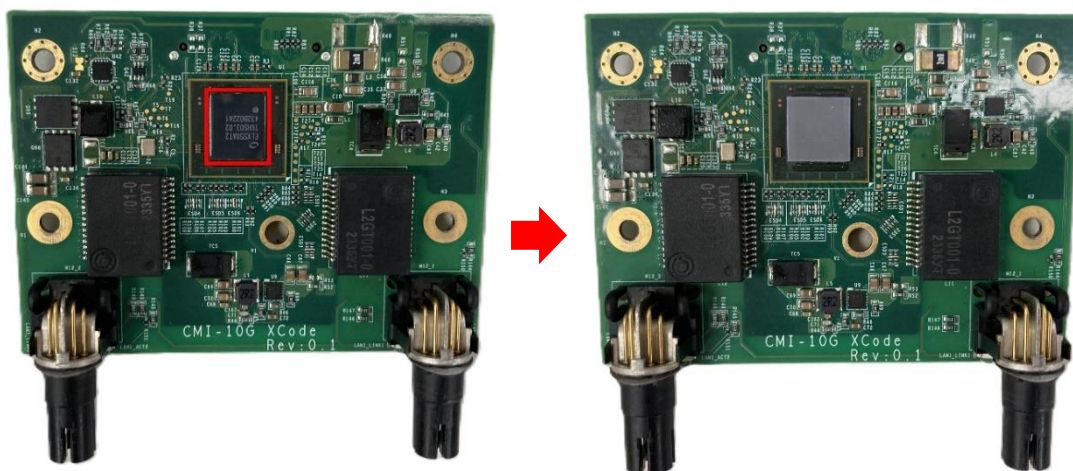

**CAUTION
(ATTENTION)**

Before putting on the heatsink (in the next step), please make sure the transparent protective film on the Thermal Pad has been removed!

(Avant de placer le dissipateur thermique (à l'étape suivante), veuillez vous assurer que le film protecteur transparent sur le pad thermique a été retiré !)

Step 5. Install the heatsink and flip the module over. Secure the heatsink with a screw as indicated.

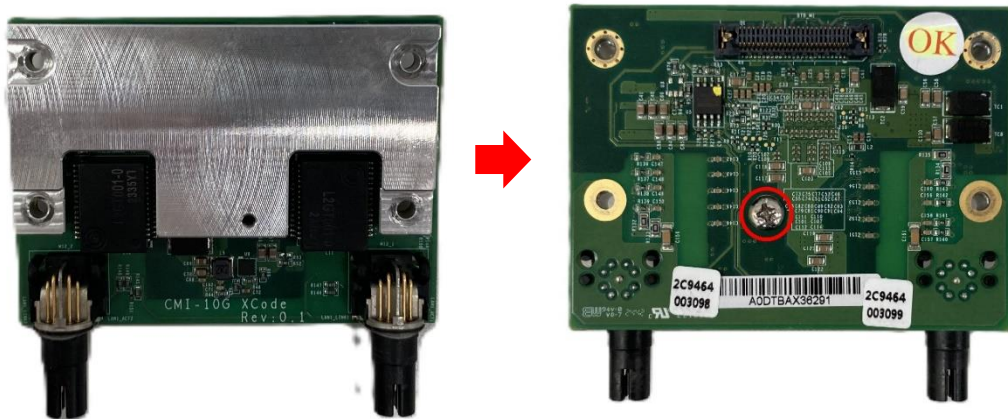

Step 6. Locate the connector BTB_FH1_DB on the GP-310 DTB.

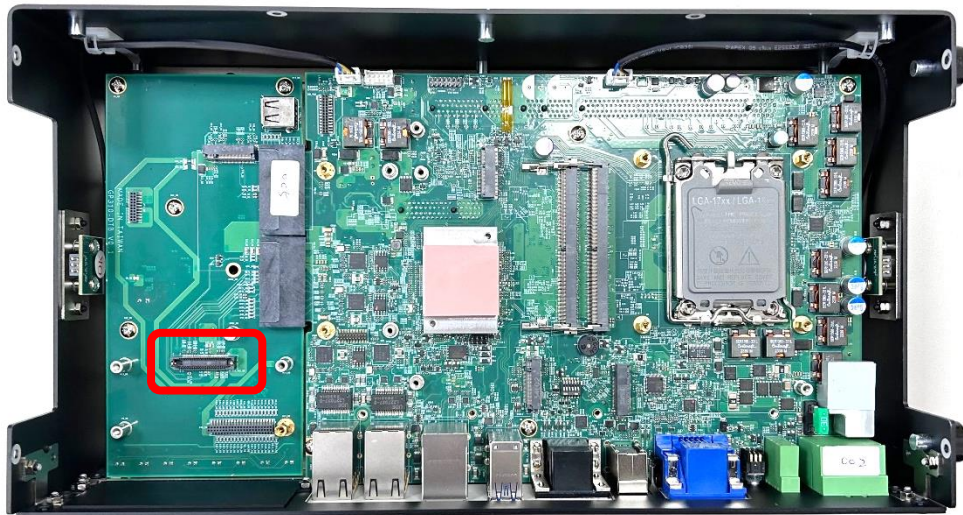

Step 7. Slot the LAN ports on the module through the holes on the bracket at an inclined angle. Press the module towards the bracket, then insert it vertically into the connector.

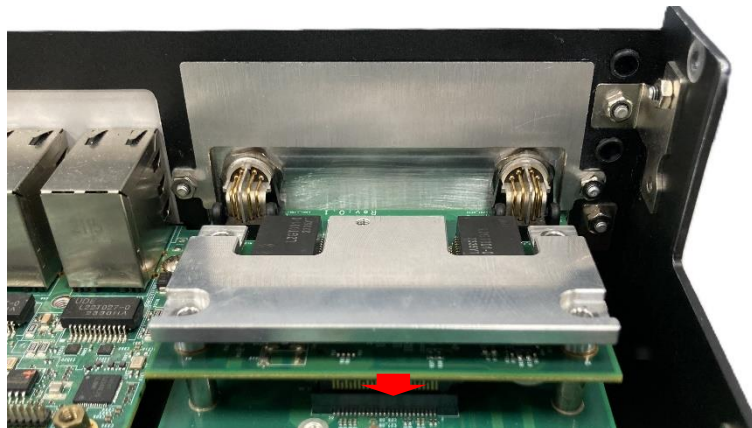

Step 8. Fasten four screws (M3x12L) to secure the module to the system.

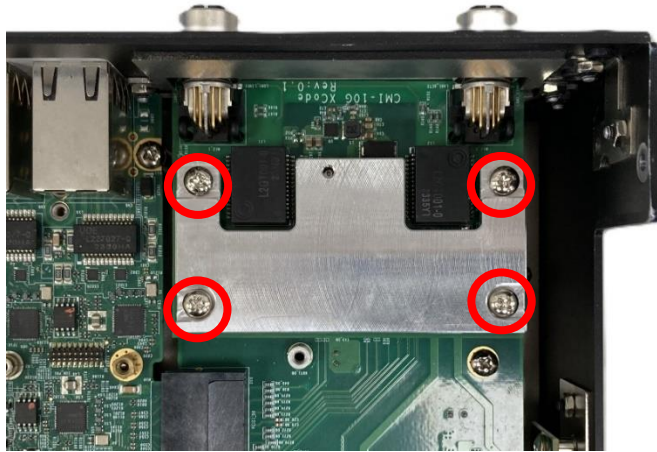

Step 9. Carefully apply the thermal pad to the heatsink.



CAUTION
(ATTENTION)

Before assembling the system's chassis cover, please make sure the transparent protective films on the Thermal Pads have been removed!

(Avant d'assembler le couvercle du châssis du système, veuillez vous assurer que les films protecteurs transparents sur les pads thermiques ont été retirés !)

Step 10. Insert the rubber rings into the XM12LAN ports. Tweezers are recommended.



3.17.7 CMI-CAN01/UB1838 Module

Step 1. Loosen the 2 hex nuts on the back side of the cover plate, then remove the cover plate.

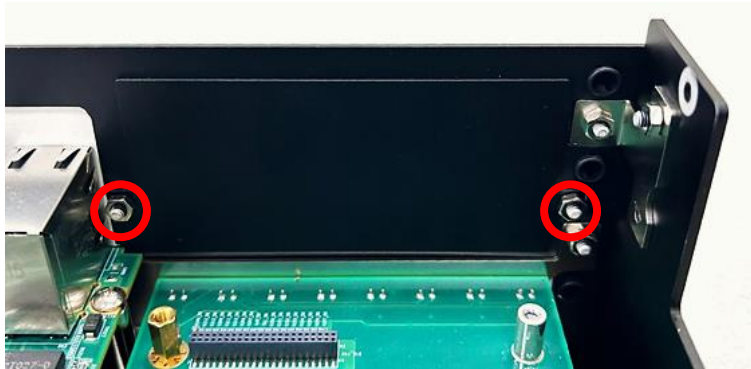

Step 3. Attach the CMI-CAN bracket, and fasten the 2 hex nuts to secure it as indicated.



Step 4. Locate the connector BTB_FH1_DB on the GP-310 DTB.

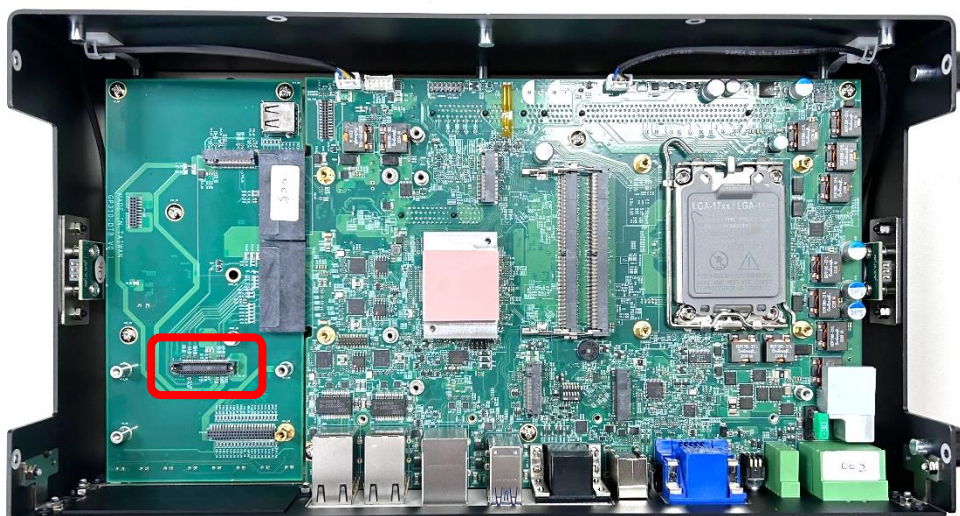

Step 5. Slot the DB9 connectors on the module through the holes on the bracket at an inclined angle. Press the module towards the bracket, then insert it vertically into the connector.

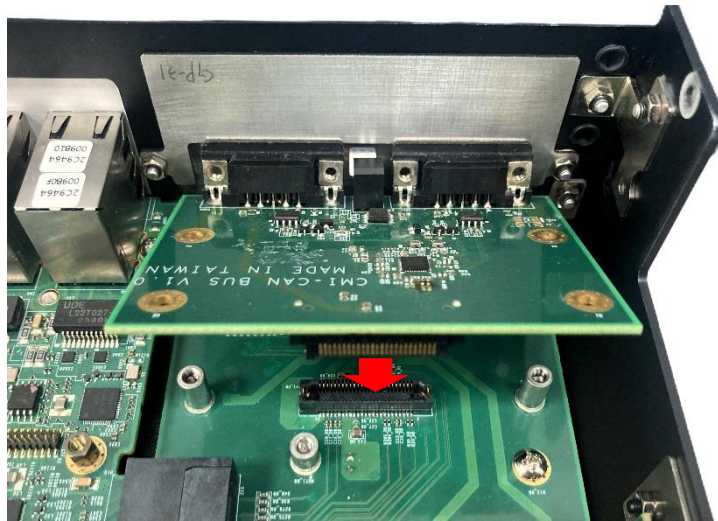

Step 6. Fasten four screws (M3x5L) to secure the module to the system.

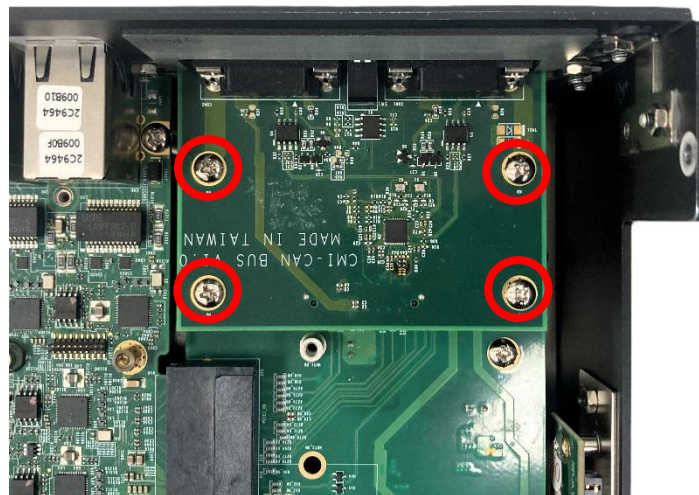

Step 7. Install the 4 D-Sub jackscrews indicated below.



3.18 Installing Low Speed CMI Module

3.18.1 CMI-DIO04/UB1818 Module

Step 1. Loosen the 2 hex nuts on the back side of the cover plate, and then remove the cover plate.



Step 2. Attach the CMI-DIO bracket, and fasten the 2 hex nuts back to fix it as indicated.

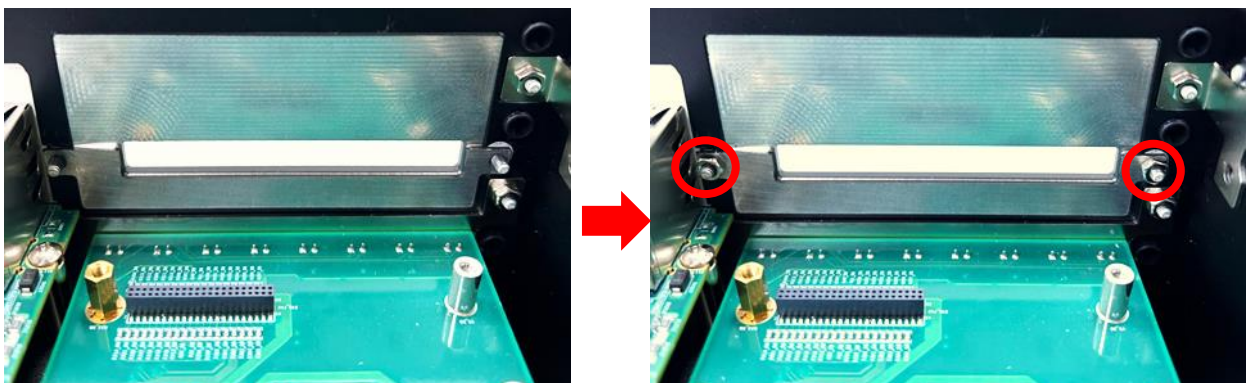

Step 3. Locate the connector BTB_FH2 on the GP-310 DTB.

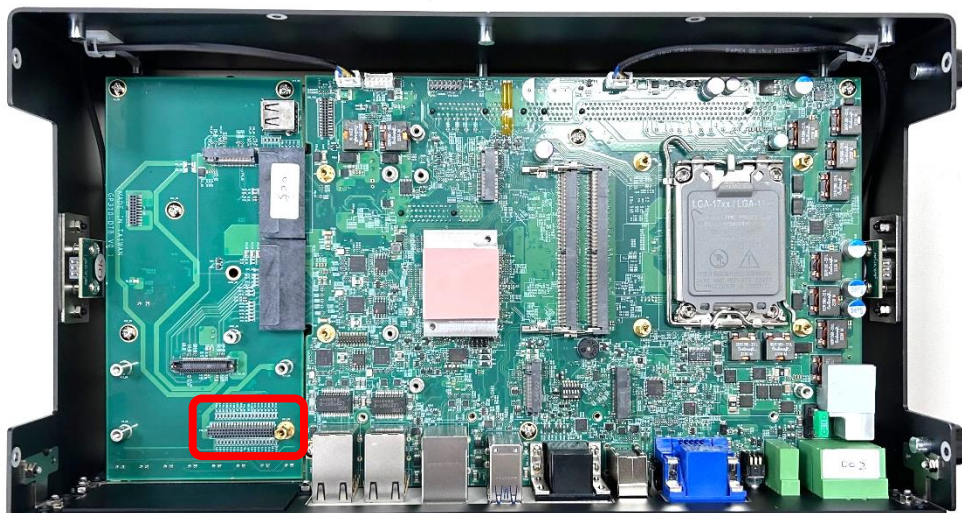

Step 4. Replace the original M3x10 standoff with an M3x23 and secure it as indicated.

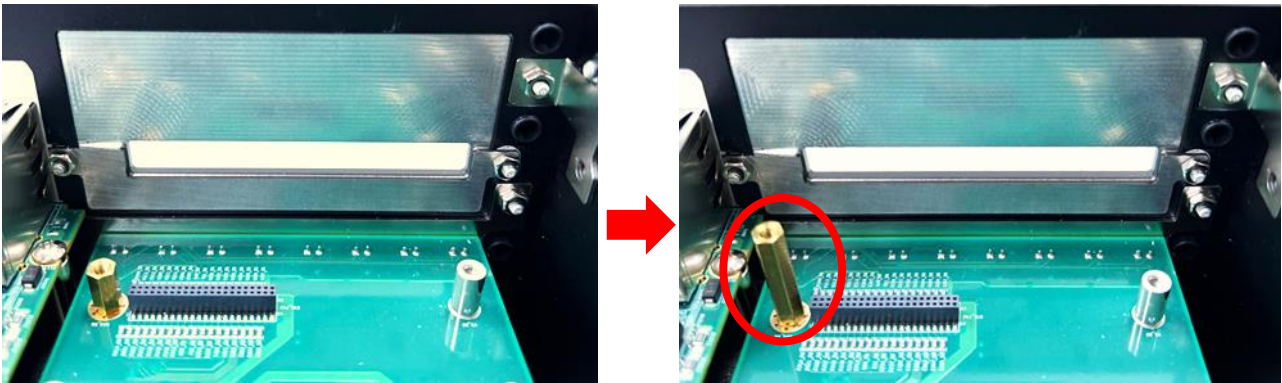

Step 5. Push the CMI-DIO module slightly and insert it vertically to the connector BTB_FH1_DB.



Step 6. Fasten the screw (M3x5L).



Step 7. Put the metal board on the module as indicated.



Step 8. Fix the module and the metal board with the three screws (1pc M3x4L, 2pcs M3x5L).

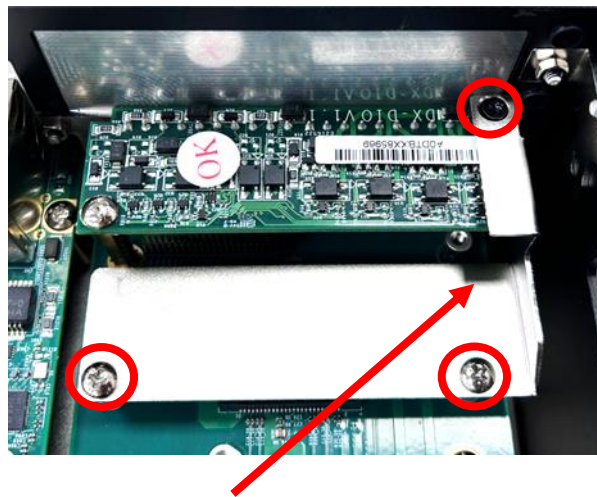

NOTE
(NOTE)

The hovering area is normal. Please do not worry.
(La zone de survol est normale. Ne vous inquiétez pas.)

Step 9. Installation is then complete, as shown below.

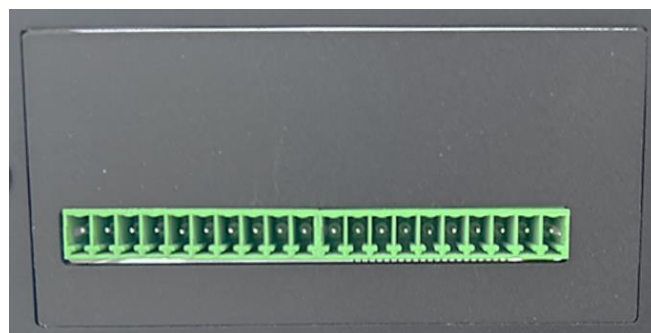

3.18.2 CMI-COM04/UB1803 Module

Step 1. Loosen the 2 hex nuts on the back side of the cover plate, and then remove the cover plate.

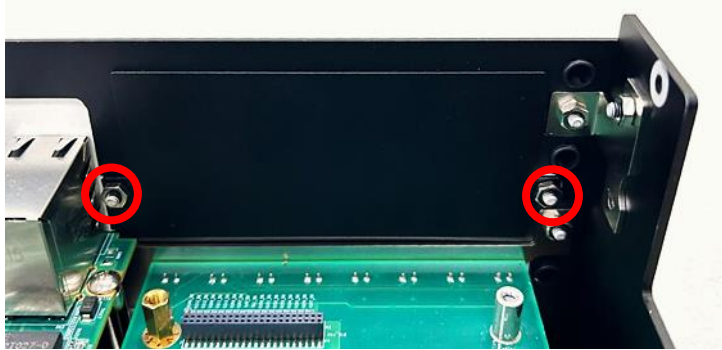

Step 2. Attach the CMI-COM bracket, and fasten the 2 hex nuts back to fix it as indicated.

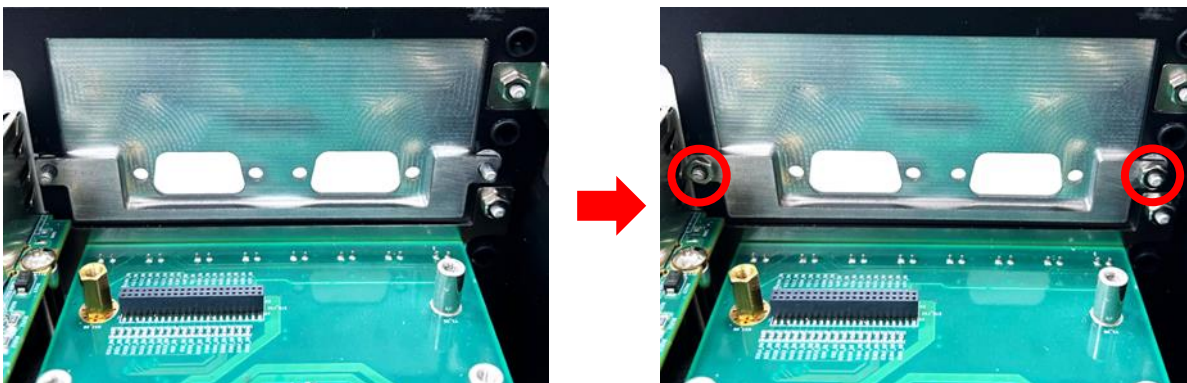

Step 3. Replace the original M3x10 standoff with an M3x23 and secure it as indicated.

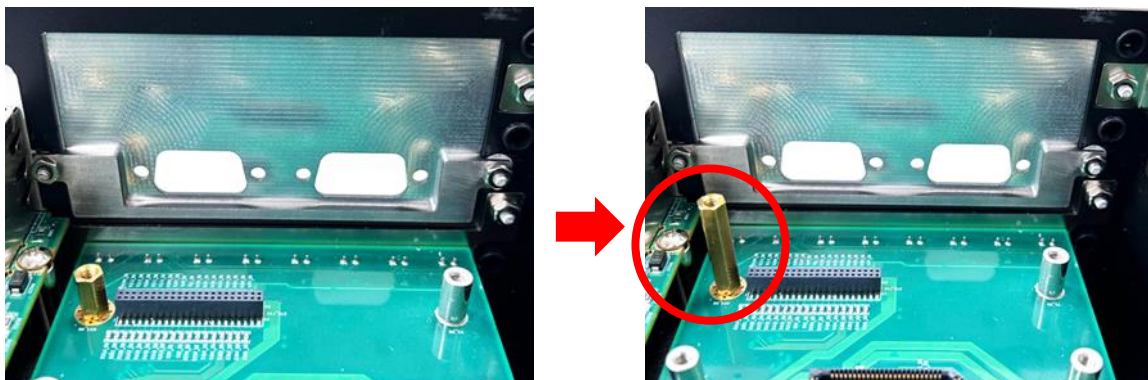

Step 4. Locate the connector BTB_FH2 on the GP-310 DTB.

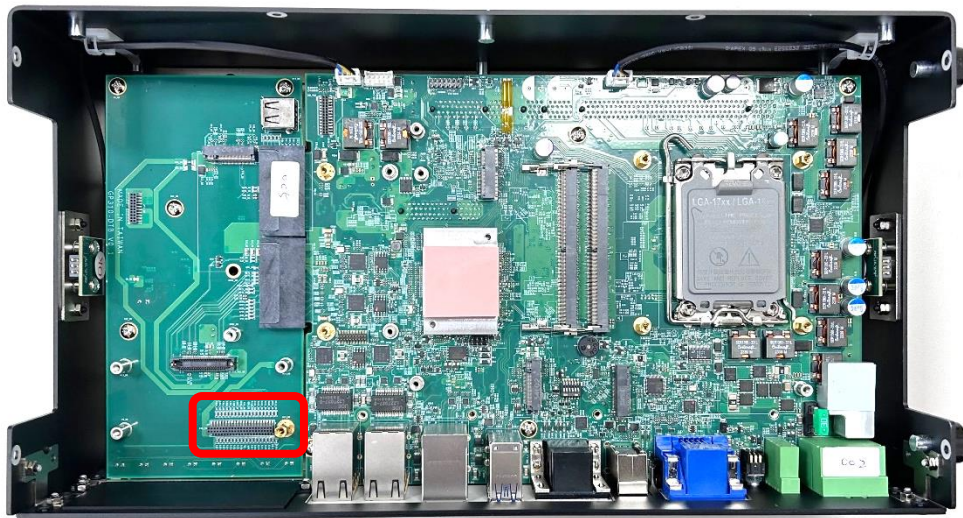

Step 5. Penetrate the CMI-COM module through the holes on the bracket.



Step 6. Push the CMI-COM module slightly and insert it vertically to the connector BTB_FH1_DB.



Step 7. Fix it with the screw (M3x5L).



**NOTE
(NOTE)**

**The hovering area is normal. Please do not worry.
(La zone de survol est normale. Ne vous inquiétez pas.)**

Step 8. Fasten the 4 D-Sub jack screws to fix the module.



3.19 Installing CFM Module

The CFM-PoE module for GP-3100 series can be installed on the system motherboard or on the CMI-LAN module. The steps for installing a CFM-PoE module (CFM-PoE01) on the motherboard will be illustrated in chapter 3.19.1. The steps for installing a CFM-PoE module (CFM-PoE07) on a CMI-LAN module will be illustrated in chapter 3.19.2.

3.19.1 CFM-PoE01 Module

Step 1. Locate the PSE Board to Board Connector (IGN_PH1) on the system motherboard as indicated.

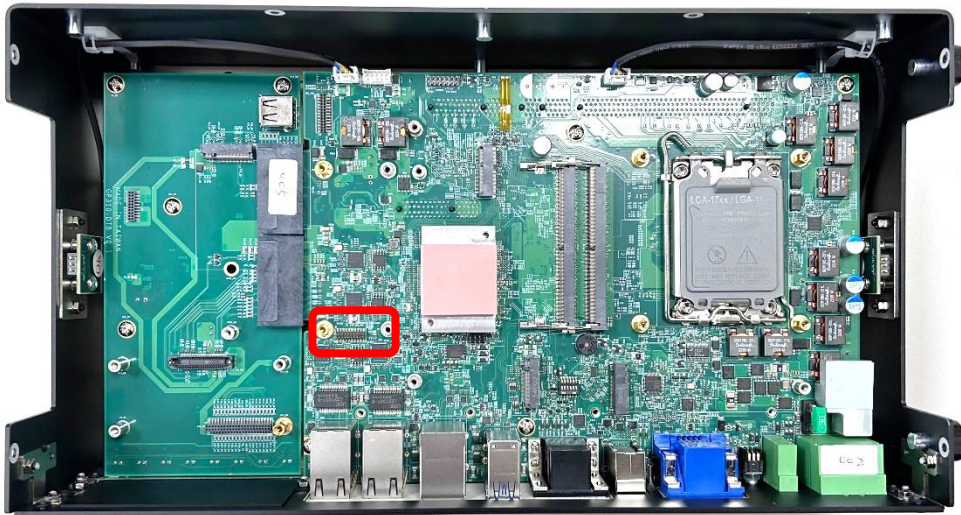

Step 2. Insert the CFM-PoE module vertically into the female connector on the motherboard until it's connected firmly.

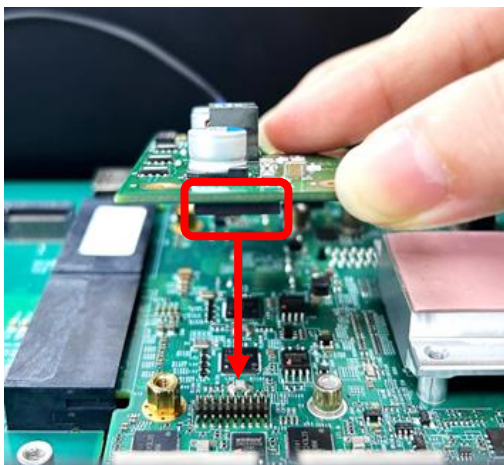

Step 3. Turn over the heatsink of the CFM-PoE module and locate the two places marked by red squares. Paste the two thermal pads as indicated onto the heatsink carefully.

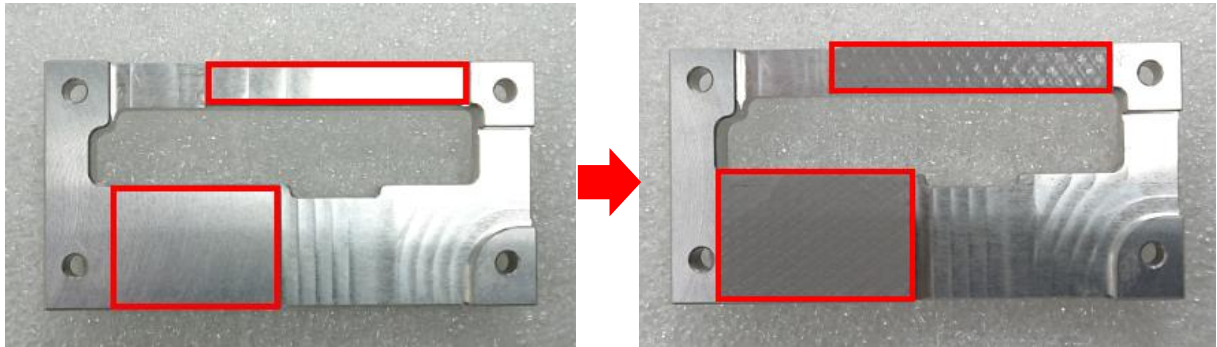

CAUTION
(ATTENTION)

Before putting on the heatsink (in the next step), please make sure the protective film on the Thermal Pad has been removed!

(Avant de poser le dissipateur thermique (à l'étape suivante), veuillez vous assurer que le film protecteur sur le pad thermique a été retiré !)

Step 4. Put the heatsink onto the CMI-PoE module carefully and then fasten the 4 screws (M3x12L) to fix it.



Step 6. Please select the yellow-blue thermal pad (one side is yellow and the other side is blue) from the module pack, and peel off the protective film on the blue side of the thermal pad first.

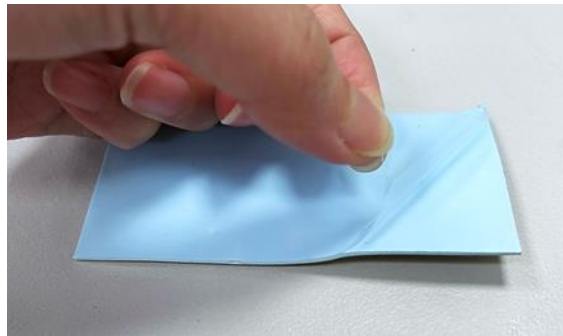

Step 7. Carefully attach the blue side of the thermal pad onto the heatsink.



CAUTION
(ATTENTION)

The yellow surface is part of the thermal pad. Do not tear it off as it would affect the thermal conductivity.

(Ne l'arrachez pas, car cela affecterait la conductivité thermique.)

Once the steps above are finished, after system power on, PoE Function LED (at system front panel, LED_B1) will light green as indicated in Chapter 2.4.

3.19.2 CFM-PoE07 Module

Due to the height of the CFM-PoE07 module, the M.2 I/O expansion is not available when the CFM-PoE07 is installed.

The CFM-PoE07 module can be installed on the CMI-LAN or CMI-M12LAN module. (This chapter will take the CMI-M12LAN module for example.)

Step 1. Please execute the installation step 1 to step 6 in Chapter 3.17.2 in advance, and fasten the 4 copper pillars (M3x5L) to fix the CMI-M12LAN module.

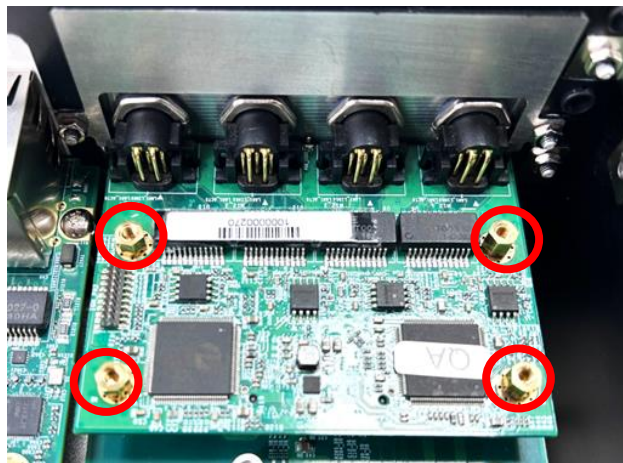

Step 2. Insert the CFM-PoE07 module vertically into the male connector on the CMI module until it's connected firmly.



Step 3. Turn over the heatsink of CFM-PoE07 and locate the two places marked by red squares. Paste the two thermal pads for CFM-PoE07 onto the heatsink carefully.

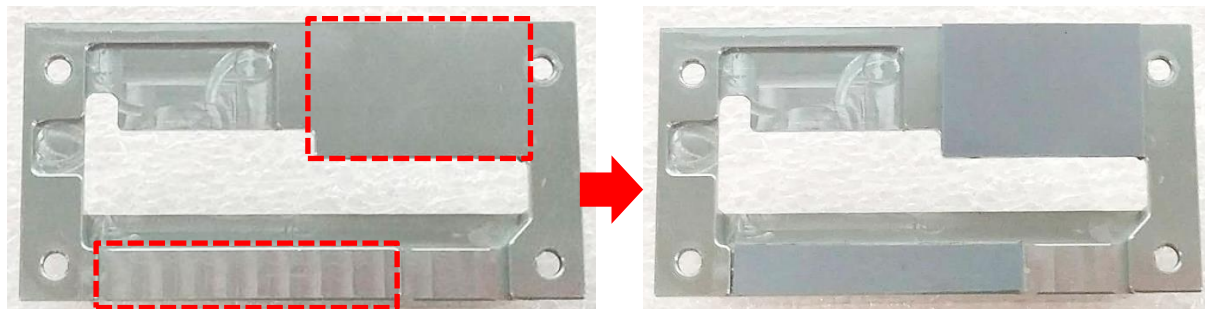

Step 4. Paste a thermal pad on the choke.



CAUTION
(ATTENTION)

Before putting on the heatsink (in the next step), please make sure the protective films on the thermal pads (step3~4) have been removed!

(Avant de placer le dissipateur thermique (à l'étape suivante), veuillez vous assurer que les films protecteurs sur les pads thermiques (étapes 3 à 4) ont été retirés !)

Step 5. Put the heatsink onto the CMI-PoE module carefully as indicated.

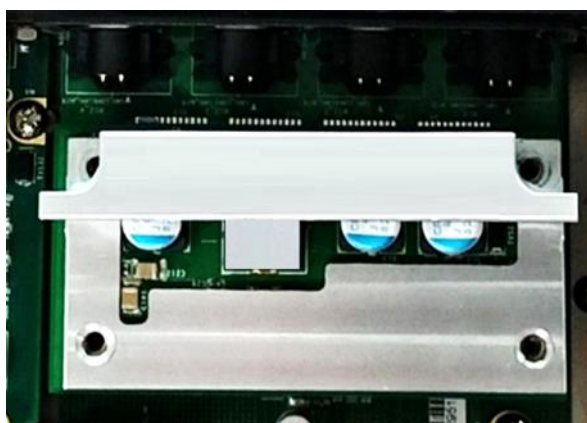

Step 6. Fasten the 4 screws (M3x12L) to fix it.

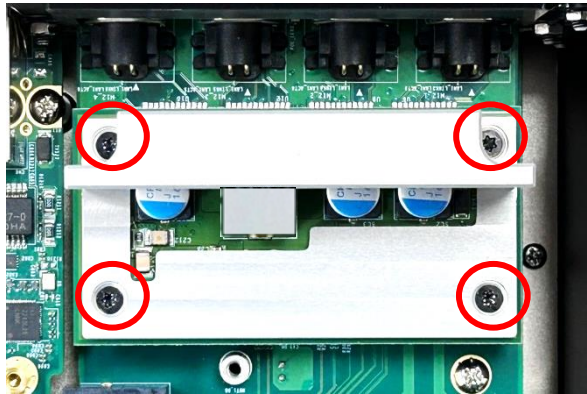

Step 7. Paste the last two thermal pads onto the heatsink carefully, and then execute the step 8 in Chapter 3.17.2 to complete the installation.



CAUTION
(ATTENTION)

Before assembling the system's chassis cover, please make sure the transparent protective film on the Thermal Pad has been removed!
(Avant d'assembler le couvercle du châssis du système, veuillez vous assurer que le film protecteur transparent sur le pad thermique a été retiré !)

Once the steps are finished, after system power on, the PoE LED (on the CMI-LAN module) will light blue as shown below.



3.19.3 CFM-IGN03 Module

Step 1. Locate the power Ignition connector (IGN_PH2) on the system motherboard as indicated.

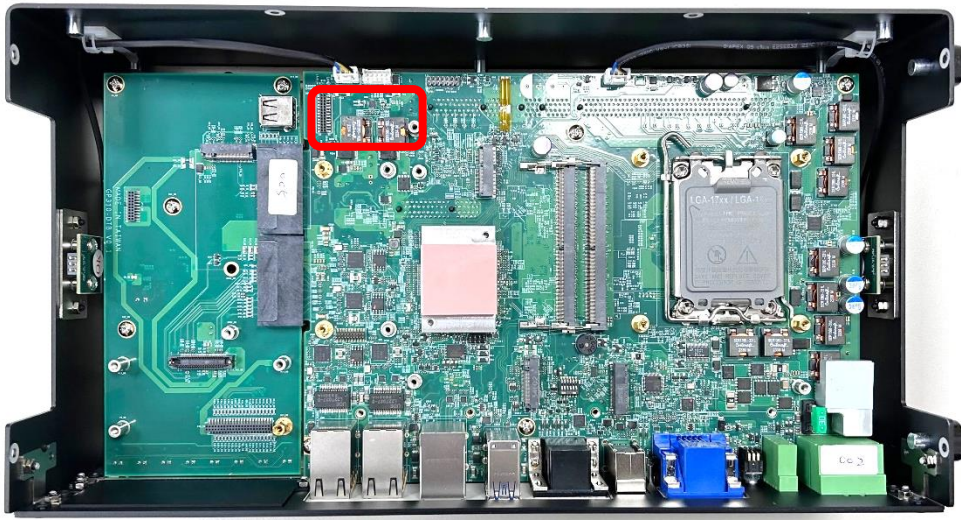

Step 2. Insert the connector of IGN module to the female connector on system motherboard. (Make sure all the pins of IGN module's connector are firmly connected.)

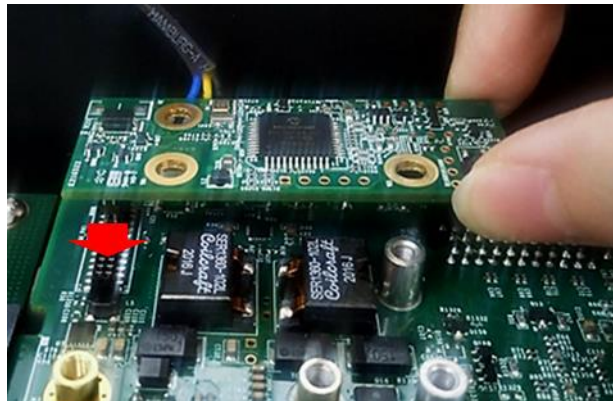

Step 3. Fasten a screw (M3x5L, included in the Module Pack) to secure the power ignition board.

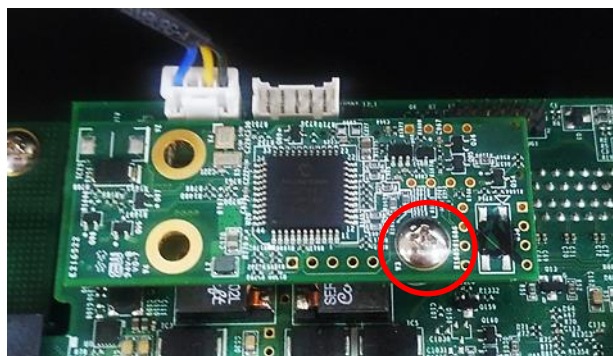

3.20 Installing GEB-3301 Module

3.20.1 Installing GEB-3301 Module onto GP-3100

Step 1. Locate the rear panel of the module. Remove the protective shell on the riser card.



Step 2. Loosen and remove the screws on the panels of the module.

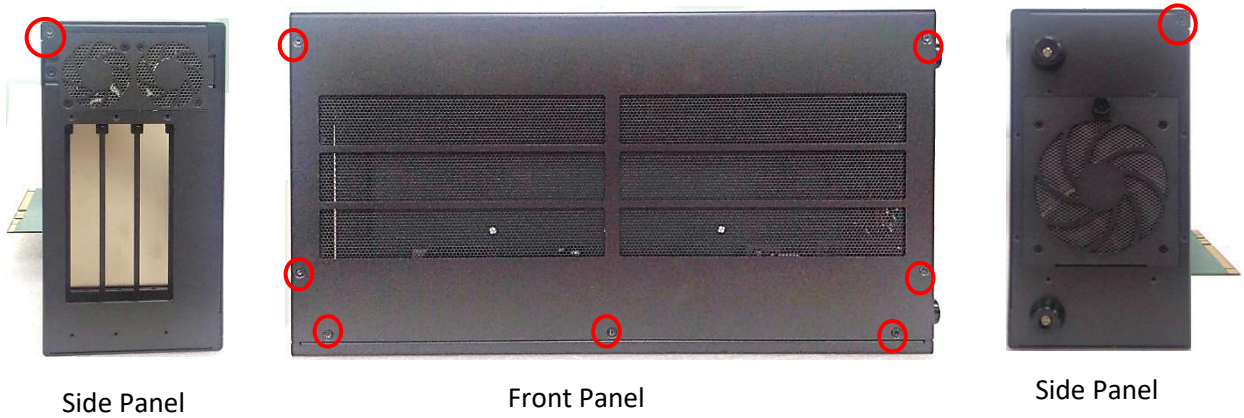

Step 3. Turn to the rear panel side of the module. Lift up and remove the top panel of the module.

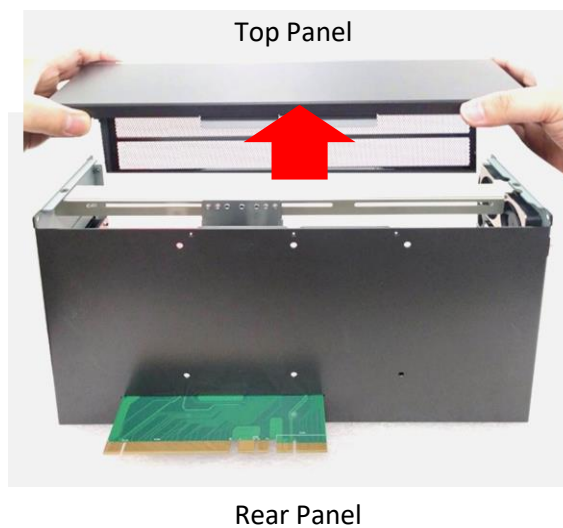

Step 4. Loosen and remove the screws on the bottom side of GP-3100 and remove the bracket.

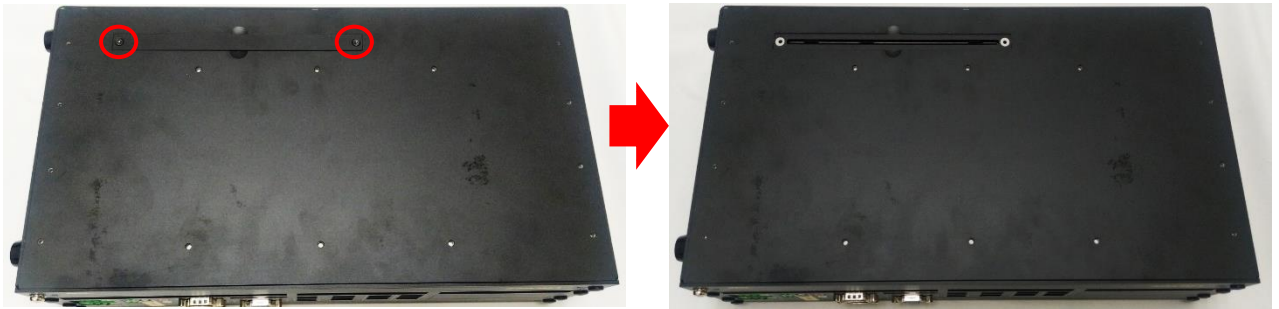

Step 5. Hold the module, align the riser card's golden pins with the socket of GP-3100. Insert the riser card firmly to the socket of GP-3100.

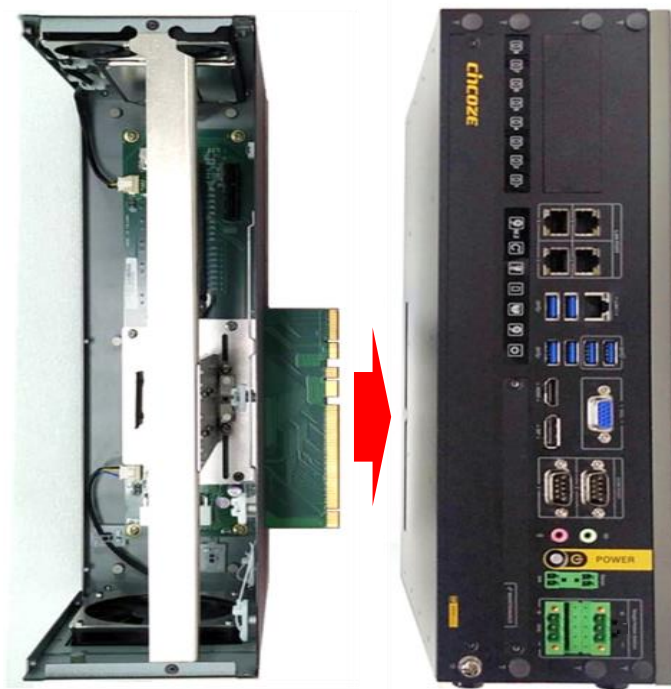

Step 6. Ensure the module is firmly connected to GP-3100, and fasten the 6 screws (M4x4L) for fixing the module and GP-3100 together.



Step 7. Put on the top panel and slide it back to the module.



Step 8. Fasten the screws back onto the panels.



Side Panel



Front Panel



Side Panel

3.20.2 Installing GPU Card



NOTE
(NOTE)

GEB-3301 maximum power budget for its PCIe16 slot is 300W. (Le budget de puissance maximal du GEB-3301 pour son emplacement PCIe x16 est de 300 W.)

Step 1. Please execute the installation step 1 to step 6 in chapter 3.20.1 first, and then loosen and remove the screw on the module's side panel.



Step 2. Press the wire and tape to close to the fan side, and then push out the fan seat.

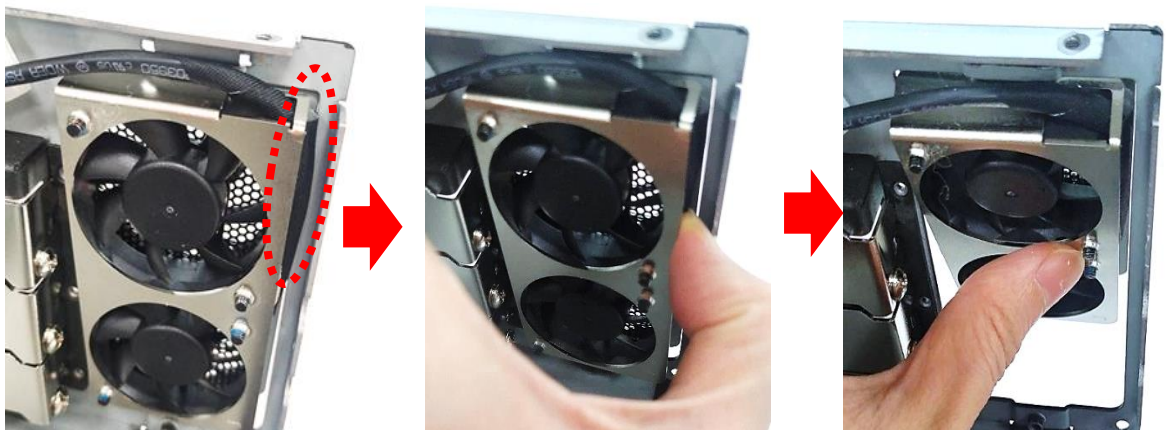

CAUTION
(ATTENTION)

This step is important! Failure to follow this step may scratch and damage the wire. (Cette étape est importante ! Ne pas suivre cette étape pourrait rayer et endommager le fil.)

Step 3. Loosen and remove the screw(s) to remove the I/O bracket(s).

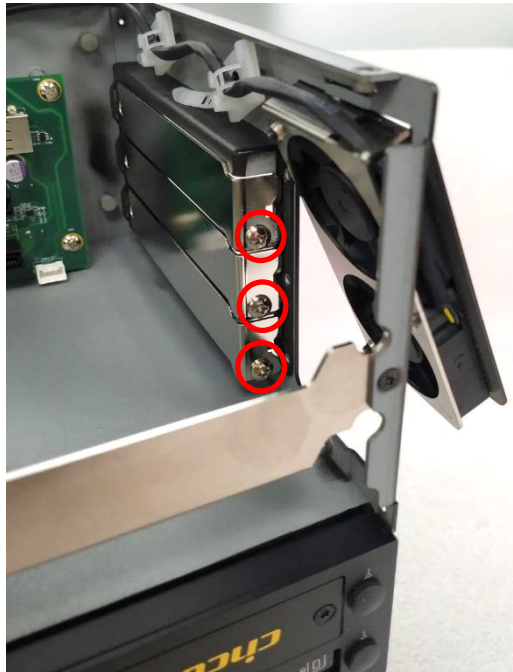

Step 4. Loosen but not remove the four screws.



Front View

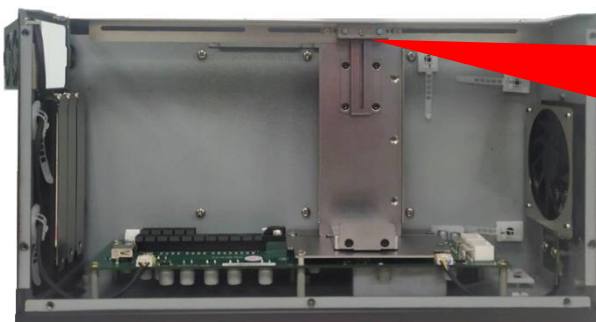
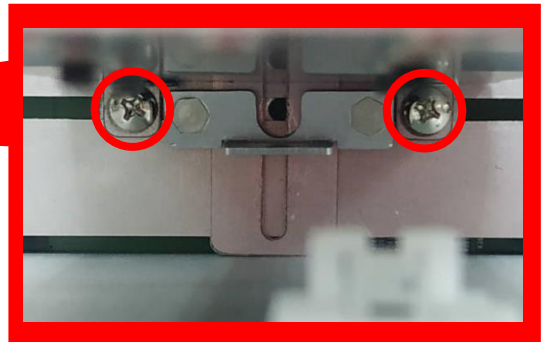

Top View



Step 5. Move the card retainer to an appropriate place according to your GPU card's dimension.

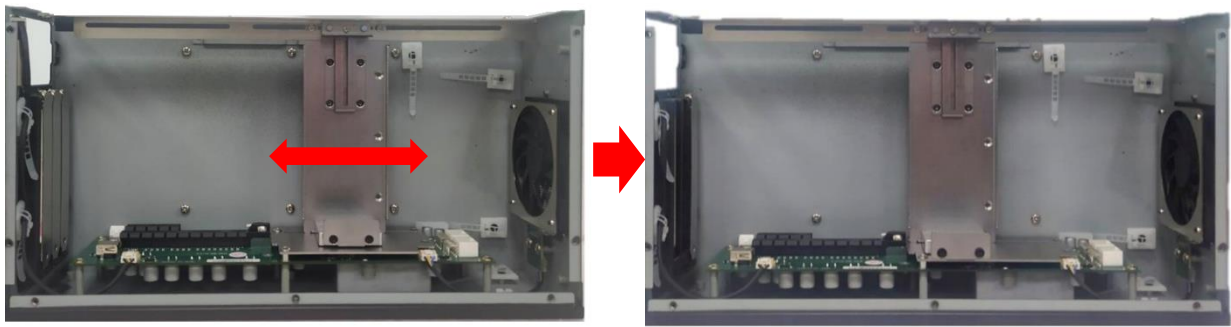

Step 6. Loosen the two screws and move the plate to an appropriate place according to the GPU card's dimension. The length of the pre-installed screws is 35 mm. User can also replace these screws with screws of two other lengths (45 mm / 25 mm) according to the GPU card's dimension.

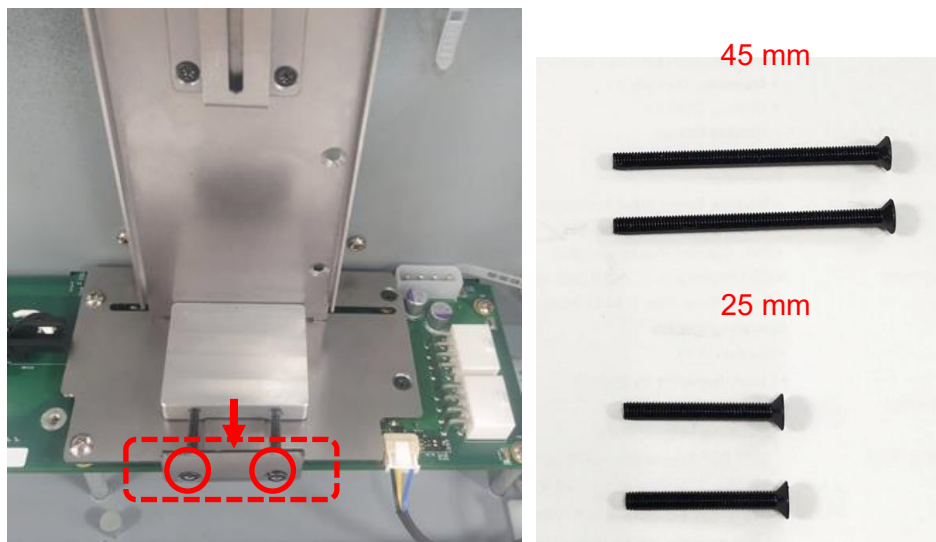

Step 7. Insert the ends of the two wires into the connectors on the PCB as indicated.

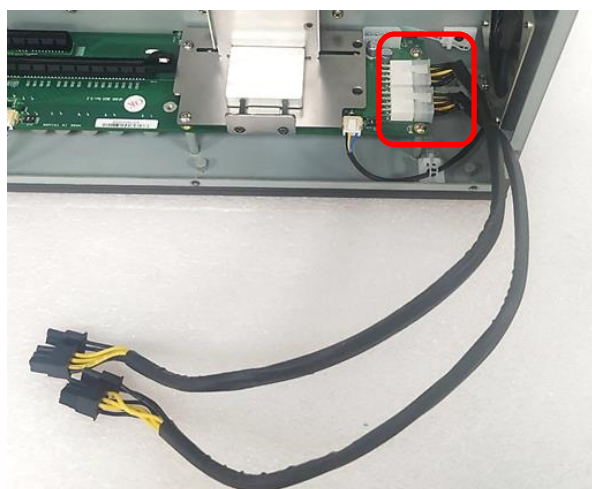

Step 8. Insert the other ends of the two wires into the connector on the GPU card. The plug of the wire is a flexible design and can be connected to the 6-pin or 8-pin connector. (The picture shown below is just an example, the actual connection should be made according to user's GPU card.)

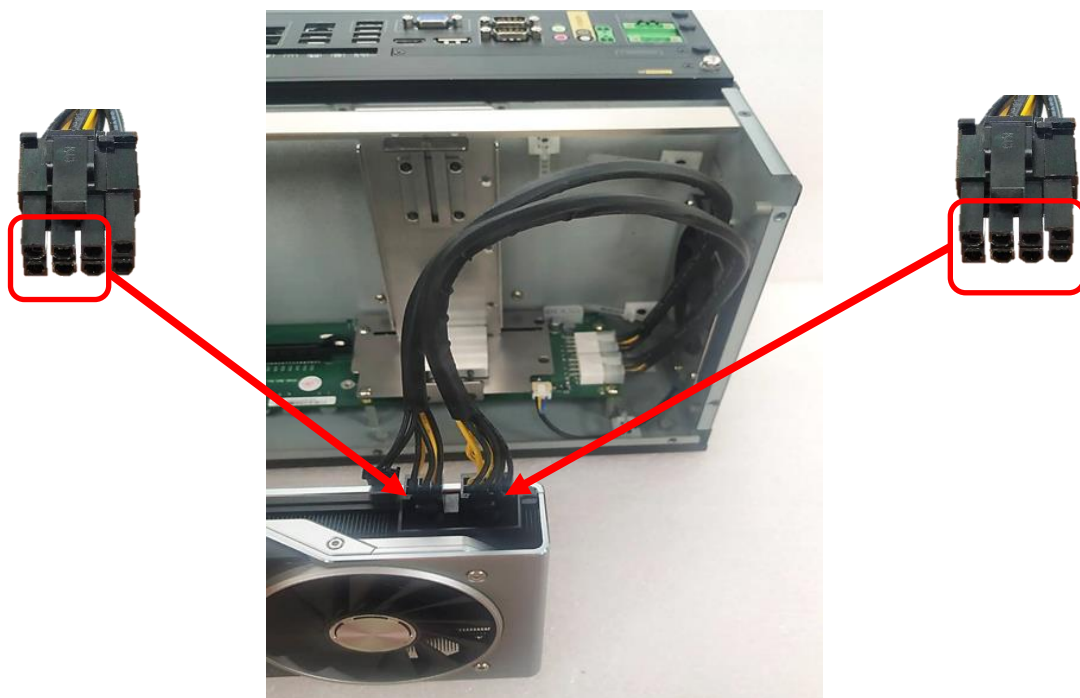

Step 9. If there is exposed PCB on the GPU card which may touch the card retainer, please paste the black sponge bars on the lateral sides of card retainer before inserting GPU card into the module. If not, please skip this step and directly go to the step 10.

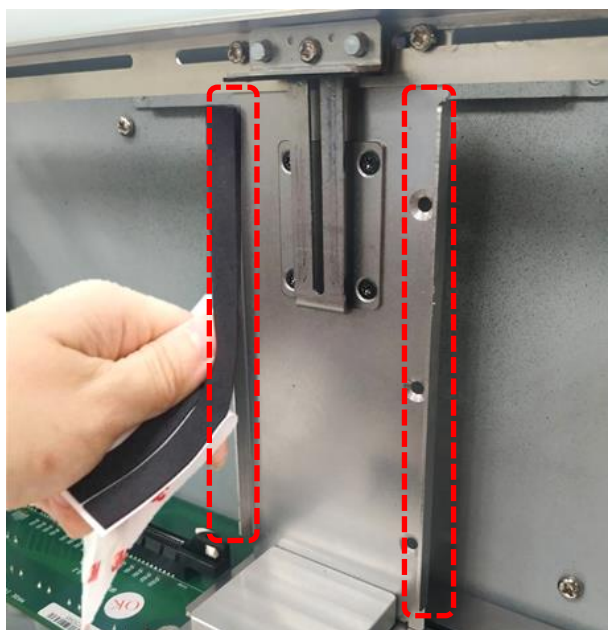

Step 10. Insert GPU card into the PCIe socket.

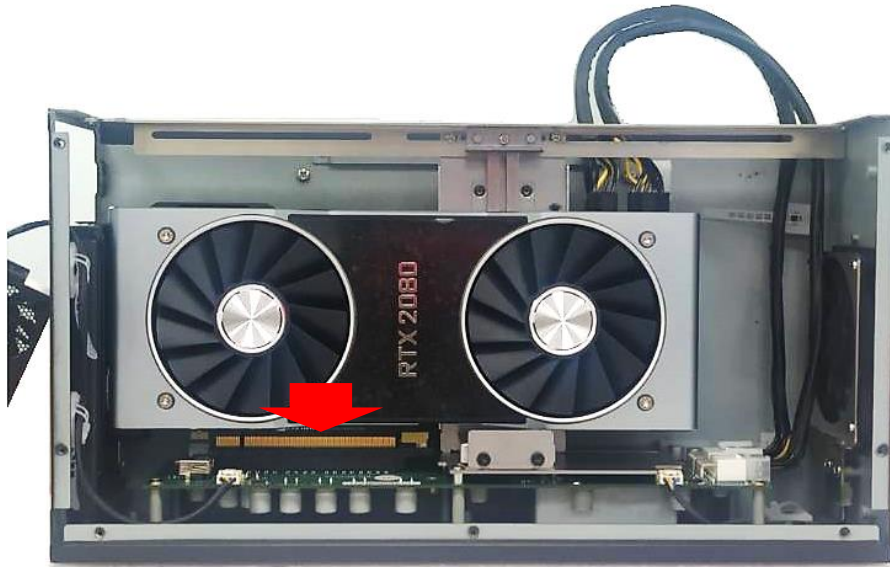

Step 11. Fasten the screws back.



Step 12. Fasten the four screws to fix the card retainer.



Front View

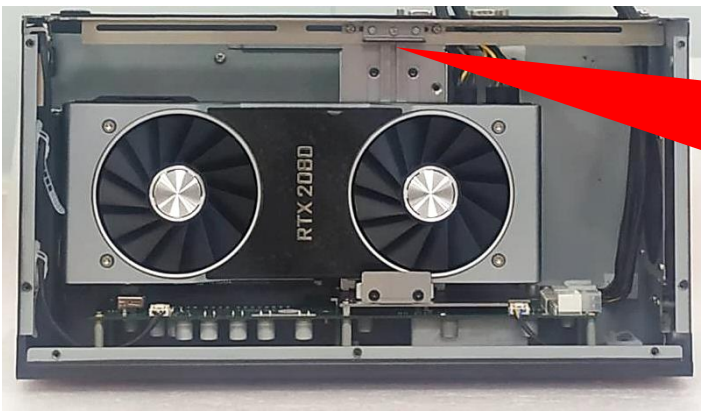
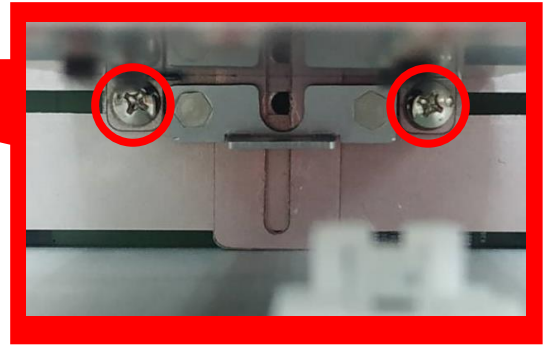

Top View

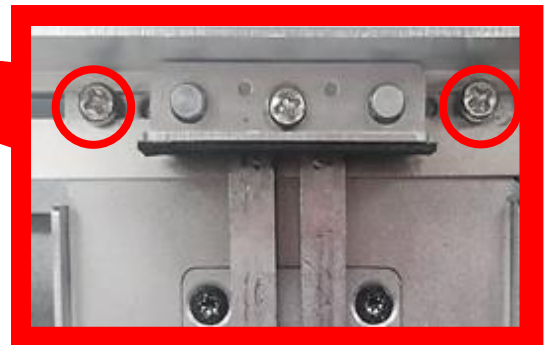

Step 13. Push the plate till it contacts the GPU card, and then fasten the two screws to fix the GPU card.



Step 14. Fasten the screw (M3X6L) to fix the card retainer.



NOTE
(NOTE)

It is normal that the GPU card might be too thick to fasten the screw to the hole. (Il est normal que la carte GPU puisse être trop épaisse pour fixer la vis dans le trou.)

Step 15. Loosen but not remove the screw.

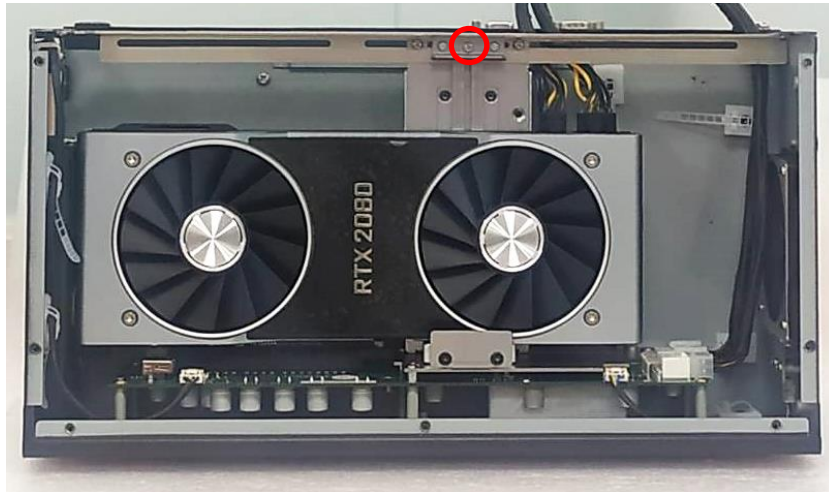

Step 16. Make sure that the metal plate slides down until it touches the GPU card, and then fasten the screw to fix the GPU card.

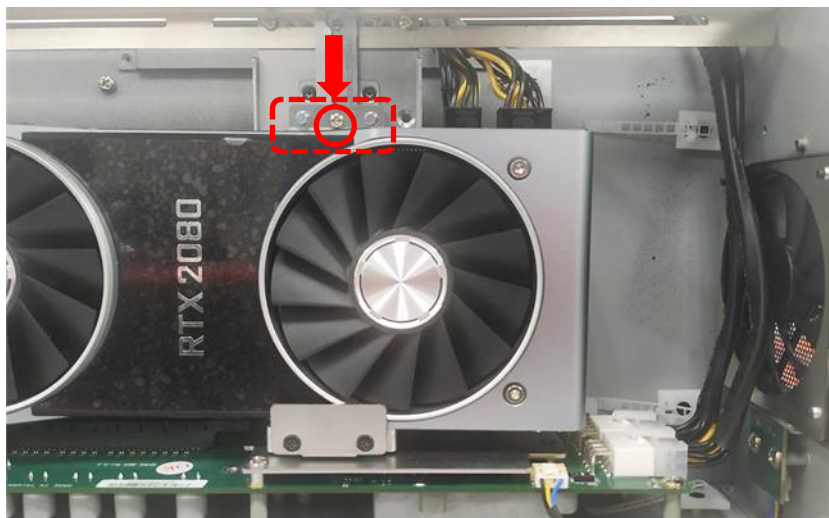

Step 17. Fasten the screw (M3x5L).



Step 18. Use the cable tie (included in the Module Pack) to tie the two wires together.

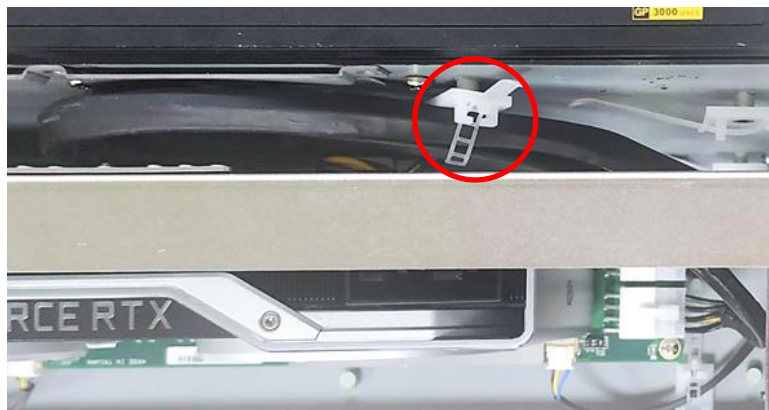

Step 19. Press the wire and tape to close to the fan side and meanwhile push the fan seat back to the module. Fasten the screw and execute the installation step 7~ 8 in chapter 3.20.1 in the end.

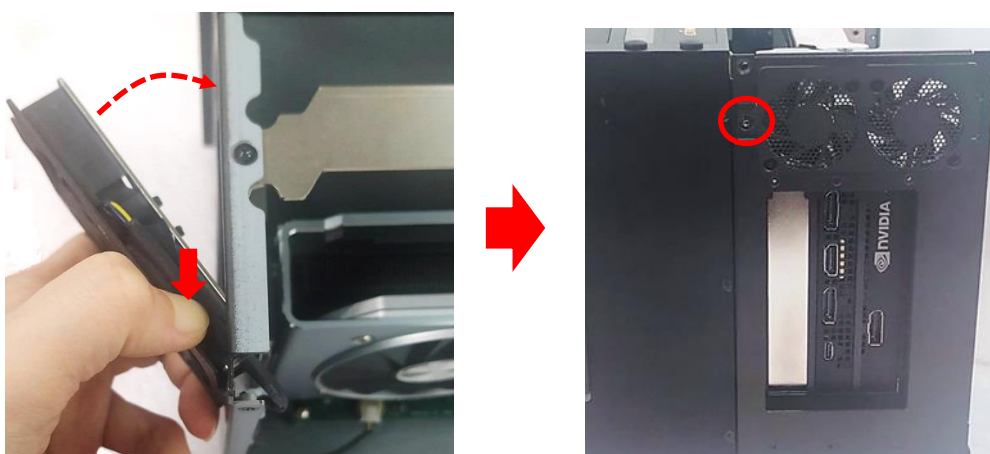

CAUTION
(ATTENTION)

This step is important! Failure to follow this step may scratch and damage the wire. (Cette étape est importante ! Ne pas suivre cette étape pourrait rayer et endommager le fil.)

3.20.3 Installing Rubber Foot Pad

Step 1. Locate the two screw holes on the side panel of GEB-3301.



Step 2. Attach on the two rubber foot pads and fasten the two screws (M4x8L) to fix them.



3.20.4 Installing Wall Mount

GP-3100 with GEB-3301 Module provides a wall mount kit that customers can install system on the wall in a convenient and economical way.

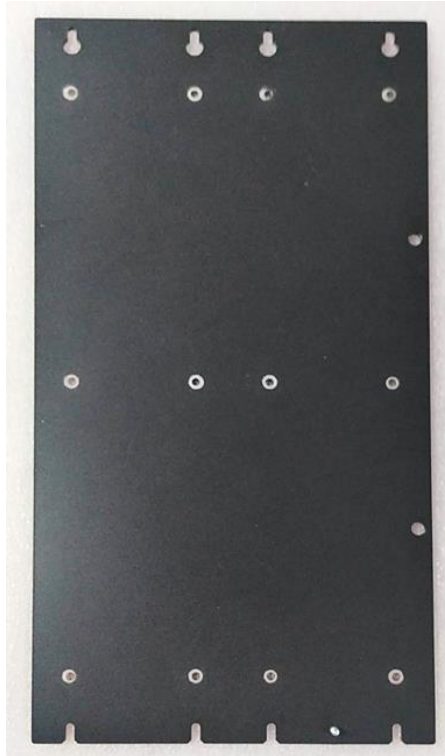

Step 1. After completing all the installation steps in chapter 3.20.1, attach the wall mount bracket onto the system according to the orientation shown below.



Step 2. Use provided 12 screws (M4x8L) to fasten the bracket.

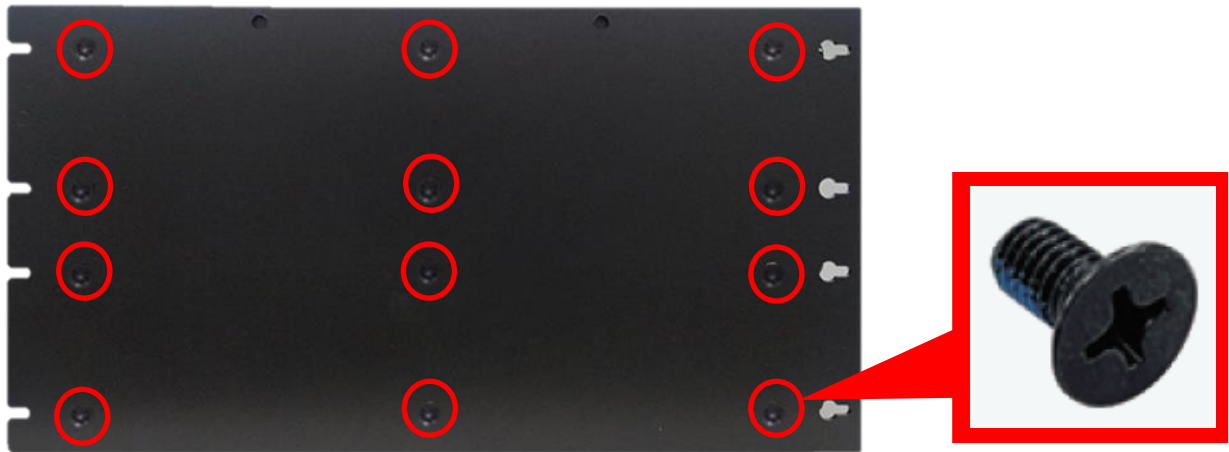

Step 3. The 4 bracket mounting holes are used to fix the system on the wall.



3.20.5 Installing 19" Rack Mount

GP-3100 with GEB-3301 Module provides the 19" Rack Mount kit that customers can install the system onto 19" Rack.

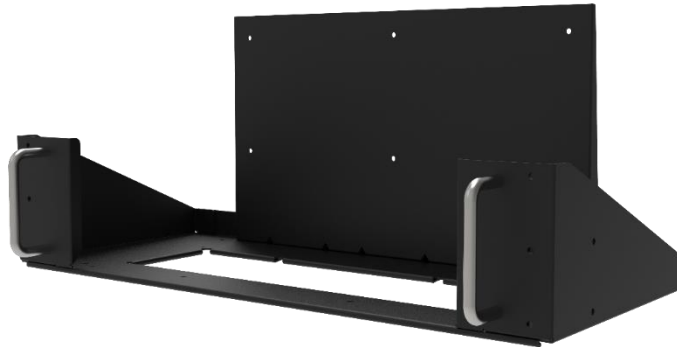

Before installing GP-3100/GEB-3301 onto the 19" Rack Mount, please follow the steps below to assemble the 19" Rack Mount kit first.

- (1) Locate the four screw holes.



- (2) Attach the two handles onto the seat bracket, and fasten the four screws (M5x12L) to fix them from the back side.

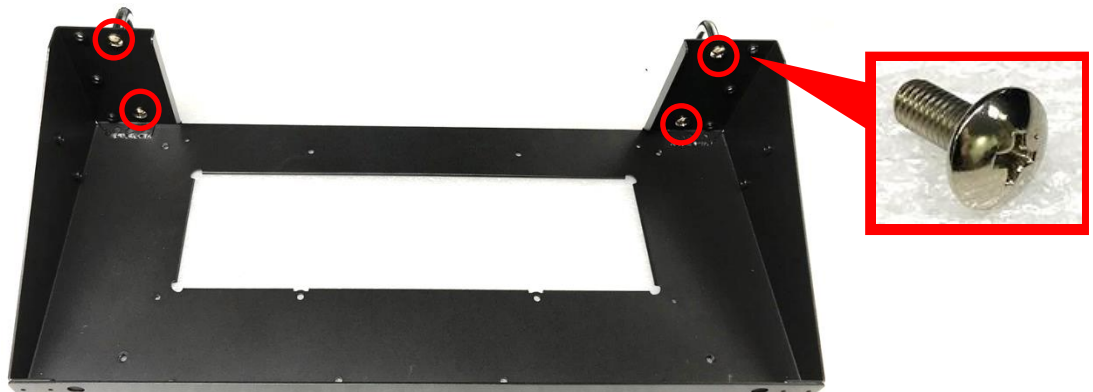

(3) Place the back panel onto the seat bracket as the indicated direction

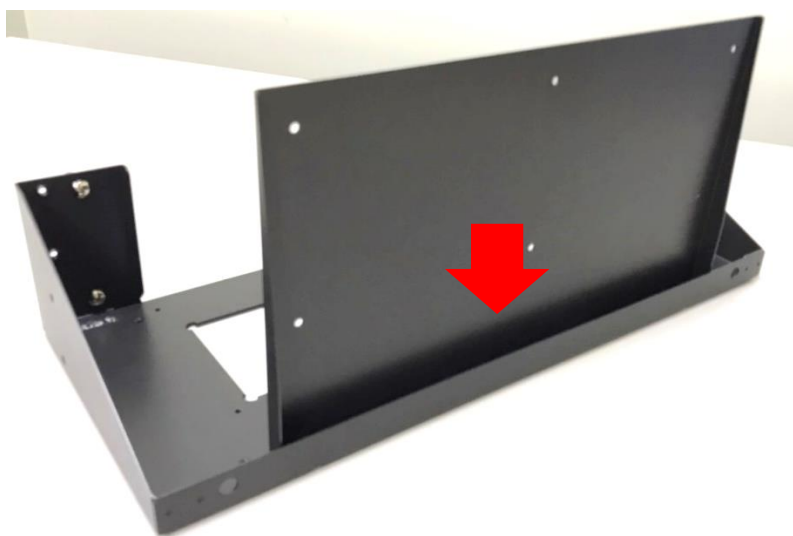

(4) Turn to the bottom side of the seat bracket, and fasten the four screws (M4x6L) to fix the back panel.



Step 1. Get assembled GP-3100/GEB-3301 ready. Loosen and remove the four screws on the front panel of the GEB-3301 module.



Step 2. Place the GP-3100/GEB-3301 into the assembled 19" Rack Mount kit.



Step 3. Turn to the bottom side of the 19" Rack Mount kit, and fasten the four screws (M3x8L).

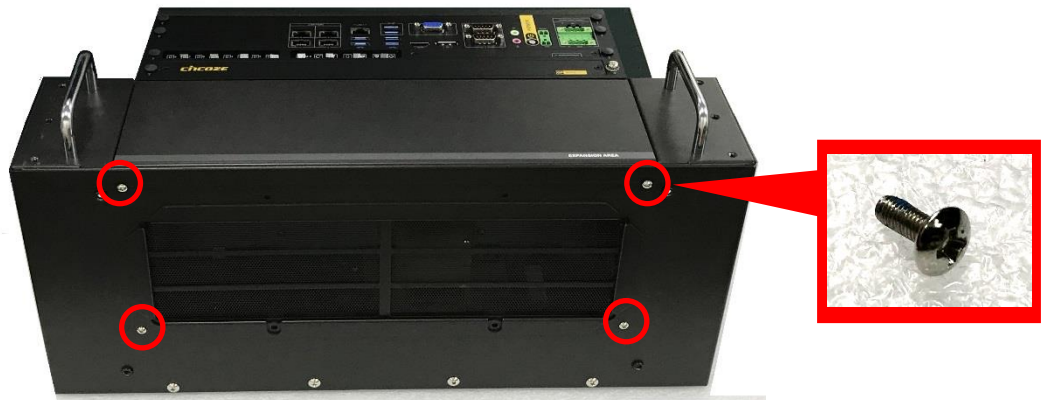

Step 4. Turn to the back side of the 19" Rack Mount kit, and fasten the 6 screws (M4x6L).

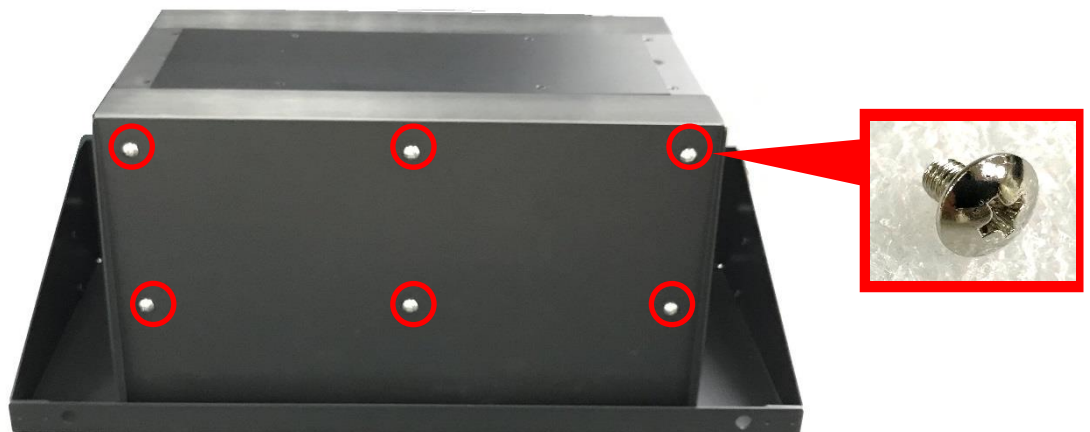

Step 5. Install the GP-3100/GEB-3301 with the 19" Rack Mount kit onto the 19" Rack by fastening screws as indicated below to complete the installation. (User needs to prepare the screws according to the rack on site)



3.21 Installing GEB-3601 Module

3.21.1 Installing GEB-3601 Module onto GP-3100

Step 1. Locate and remove the rear panel of the module. Remove the protective shell on the riser card.

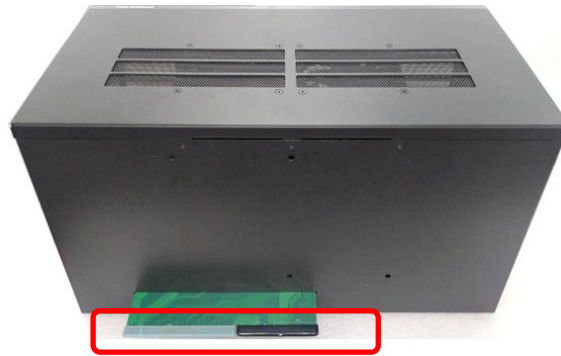

Step 2. Loosen and remove the screws on the panels of the module.

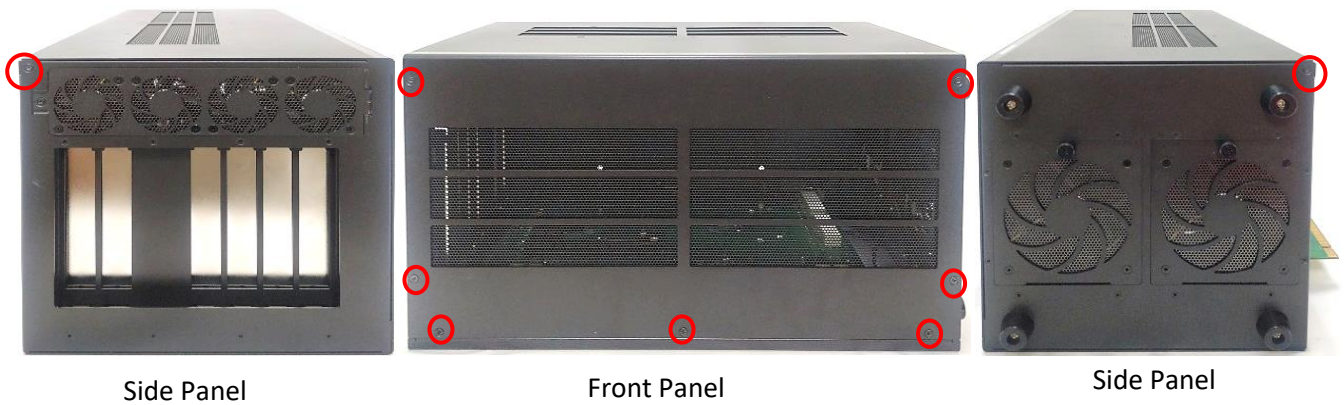

Step 3. Turn to the rear panel. Press the left side of the top panel, and lift the right side of the top panel up at about 30 degrees. Then keep the angle, gently and horizontally pull the top panel away.

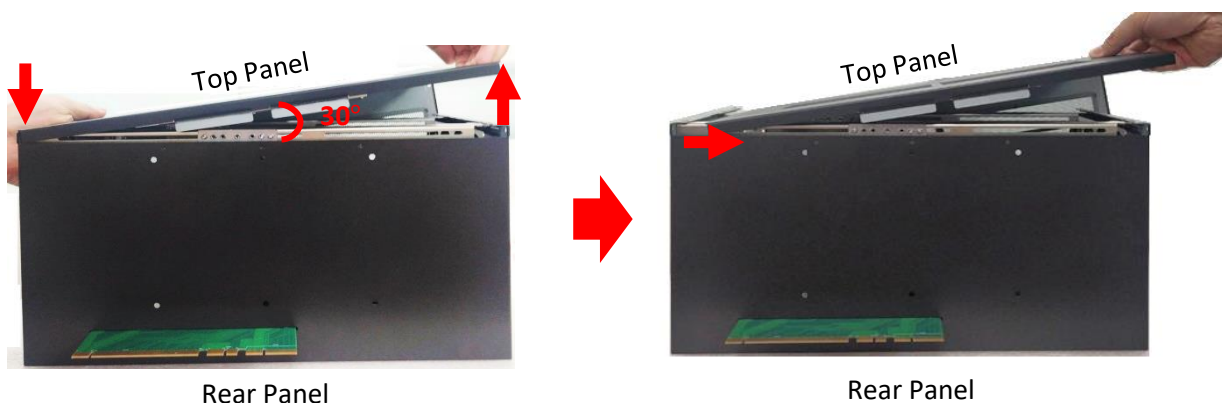

WARNING
(AVERTIR)

This step is very important! Failure to follow this step will damage the fan power connector. (Cette étape est très importante ! Ne pas suivre cette étape endommagera le connecteur d'alimentation du ventilateur.)

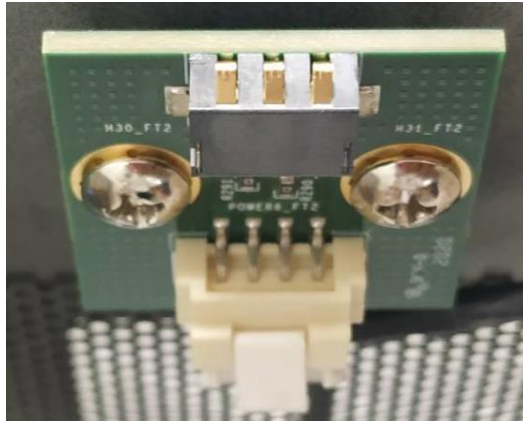

Fan Power Connector on GEB-3601

Step 4. Loosen and remove the two screws on the bottom side of GP-3100 and remove the bracket.

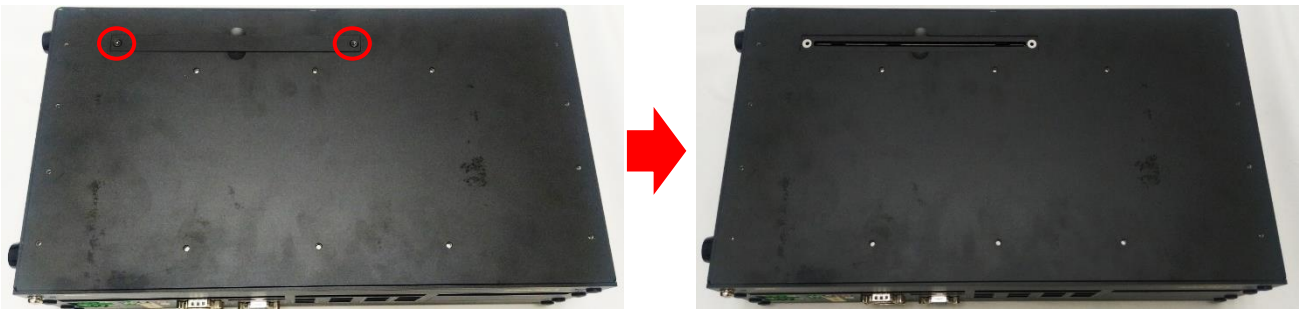

Step 5. Hold the module, align the riser card's golden pins with the socket of GP-3100. Insert the riser card firmly to the socket of GP-3100, and ensure the module is firmly connected to GP-3100.

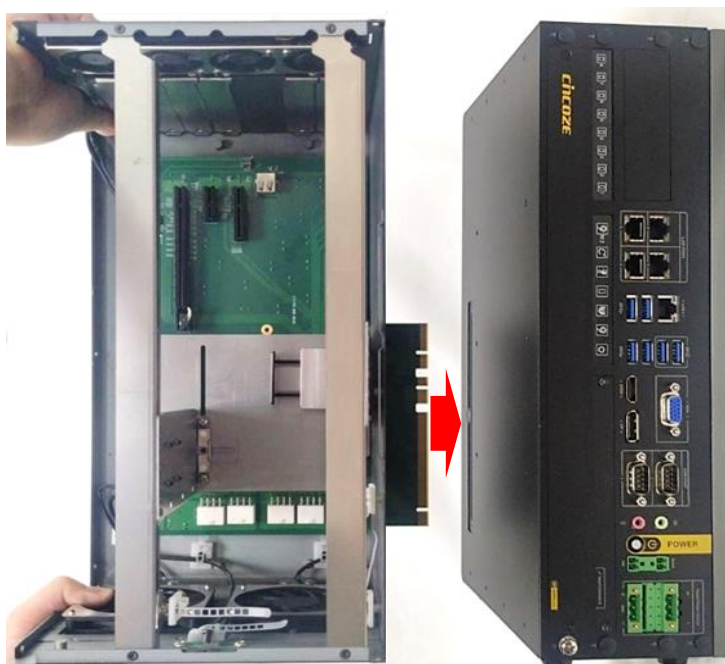

Step 6. Fasten the six screws (M4x4L).

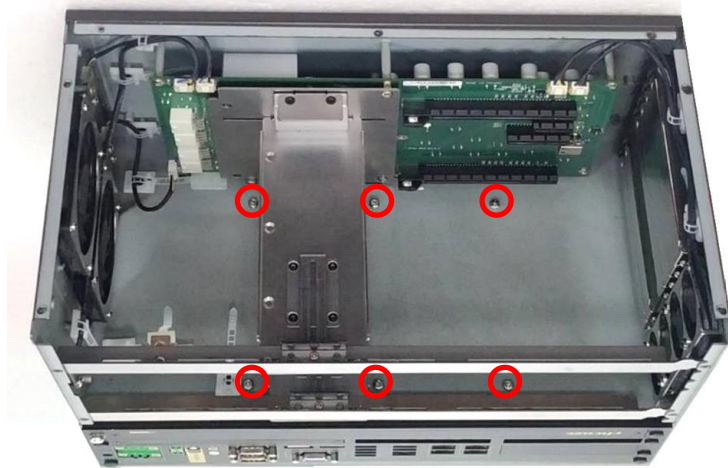

Step 7. Assembling the top panel back to the module.

7.1 Press the left side and hold the right side of the module's top panel at about 30 degrees as the picture below.



7.2 Keep holding the left side of the module's top panel, and press down the location on the panel as indicated.



7.3 Keep holding the left side of the module's top panel, and press down the location on the panel as indicated.



**WARNING
(AVERTIR)**

This step is very important! Failure to follow this step will damage the fan power connector. (Cette étape est très importante ! Ne pas suivre cette étape endommagera le connecteur d'alimentation du ventilateur.)



Fan Power Connector on GEB-3601

Step 8. Fasten the 9 screws on the panels.



Side Panel

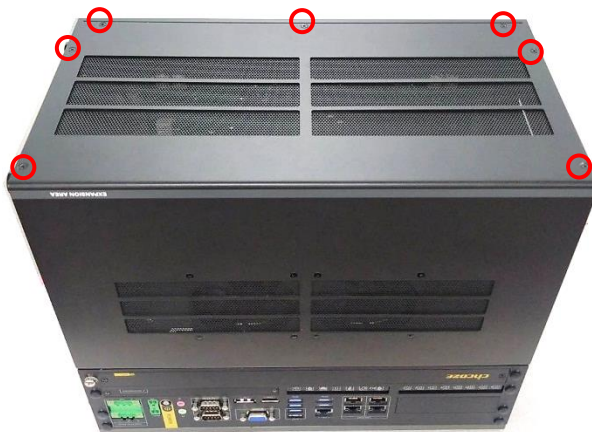

Front Panel



Side Panel

3.21.2 Installing GPU Card



NOTE
(NOTE)

GEB-3601 maximum power budget for its two PCIe16 slots is 600W (@48 VDC). When only one PCIe16 slot is connected, it has maximum power budget of 300W. When two PCIe16 slots are connected, each slot has maximum power budget of 300W (@ 48VDC).

(Le budget de puissance maximal du GEB-3601 pour ses deux emplacements PCIe x16 est de 600W (@48 VDC). Lorsqu'un seul emplacement PCIe x16 est connecté, il a un budget de puissance maximal de 300 W. Lorsque les deux emplacements PCIe x16 sont connectés, chaque emplacement a un budget de puissance maximal de 300W (@ 48VDC).)

Step 1. Please execute the installation step 1 to step 6 in chapter 3.21.1 first, and then loosen and remove the screw on the module's side panel.

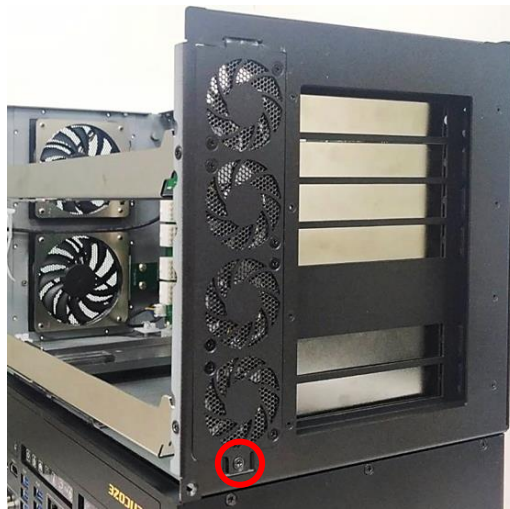

Step 2. Press the wire and tape to close to the fan side, and then push out the fan seat.



CAUTION
(ATTENTION)

This step is important! Failure to follow this step may scratch and damage the wire. (Cette étape est importante ! Ne pas suivre cette étape pourrait rayer et endommager le fil.)

Step 3. Loosen and remove the screw(s) to remove the I/O bracket(s).

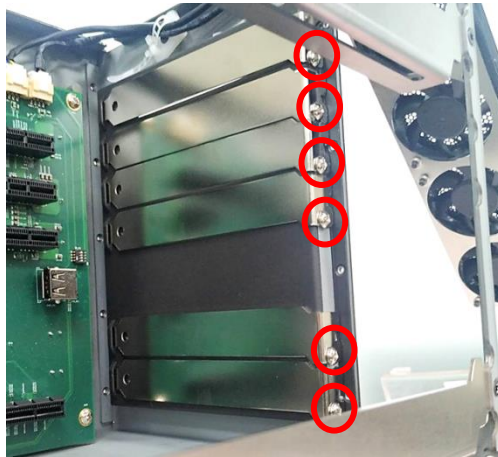

Step 4. Loosen but not remove the four screws.



Front View

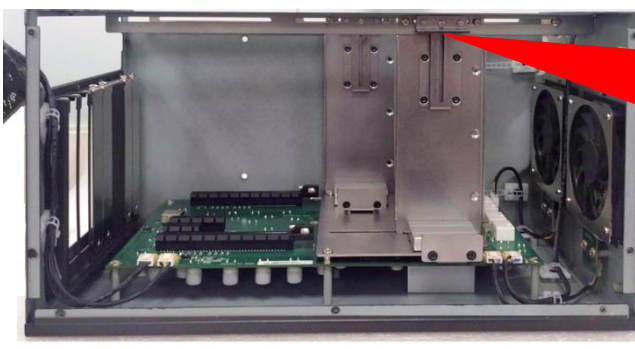
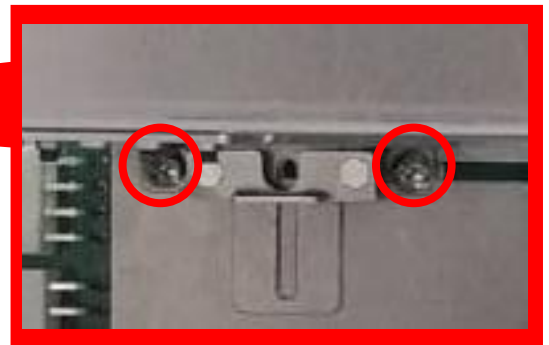

Top View

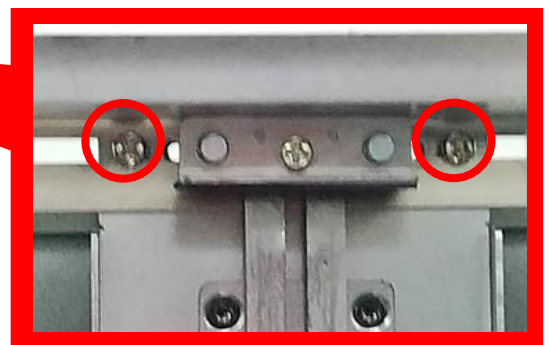

Step 5. Move the card retainer to an appropriate place according to the GPU card's dimension.

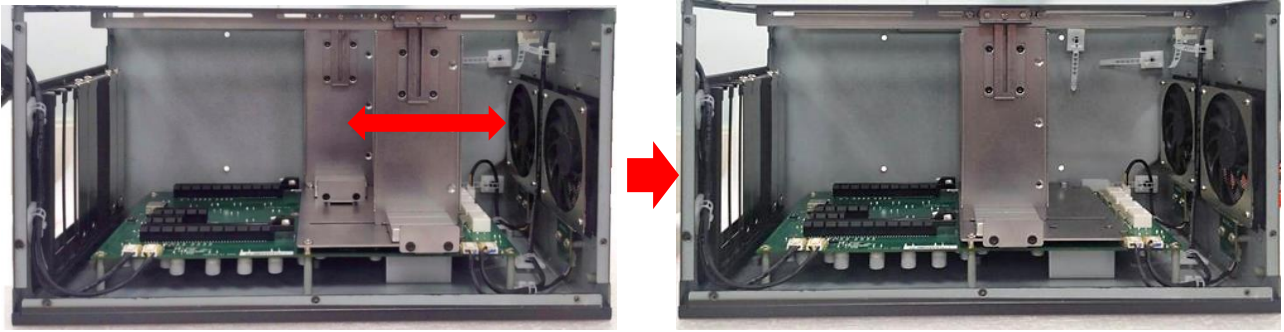

Step 6. Loosen the two screws and move the plate to an appropriate place according to your GPU card's dimension. The length of the pre-installed screws is 35 mm. User can also replace these screws with screws of two other lengths (45 mm/ 25 mm) according to the GPU card's dimension.

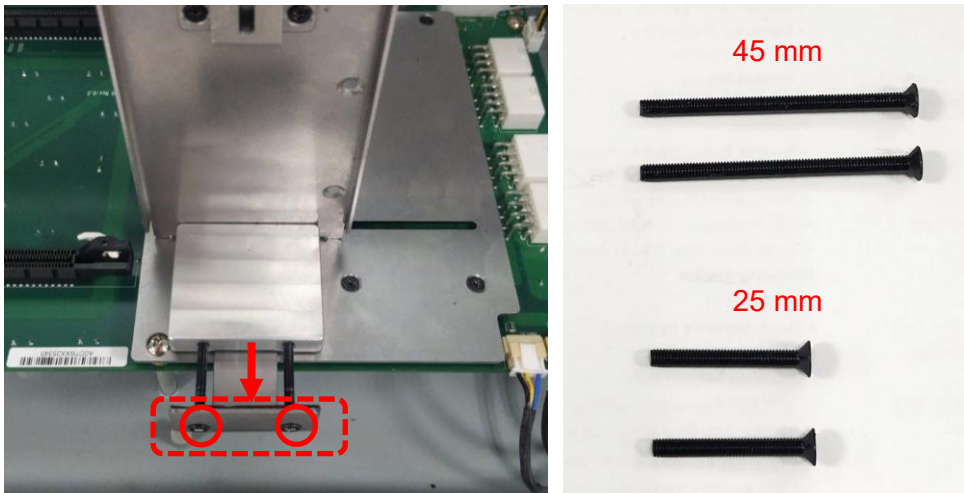

Step 7. Insert the GPU power cables into the power connectors (red set or blue set) as indicated.

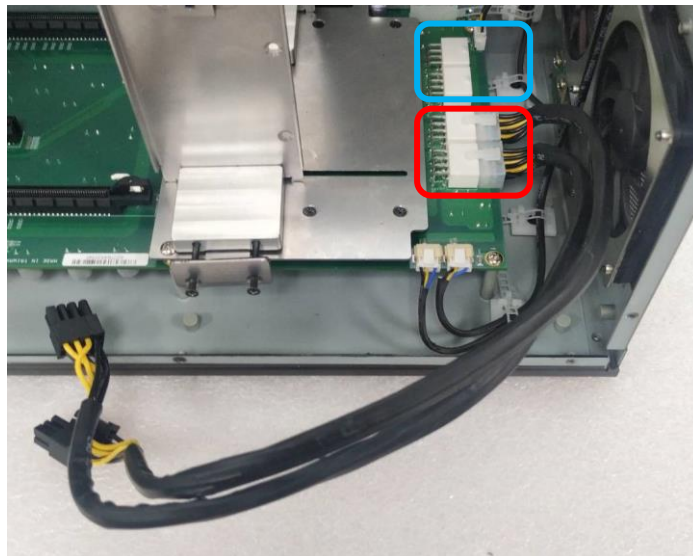

Step 8. Insert the other ends of the two wires into the connector on the GPU card. The plug of the wire is a flexible design and can be connected to the 6-pin or 8-pin connector. (The picture shown below is just an example, the actual connection should be made according to user's GPU card.)

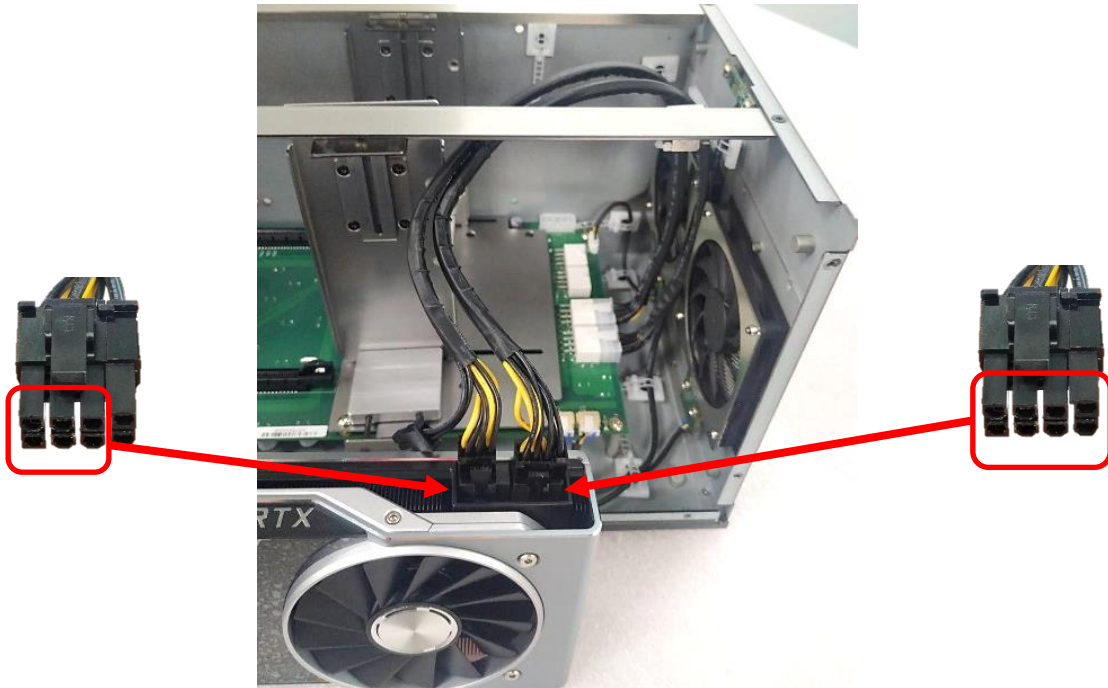

Step 9. If there is exposed PCB on the GPU card which may touch the card retainer, please paste the black sponge bars on the lateral sides of card retainer before inserting GPU card into the module. If not, please skip this step and directly go to the step 10.

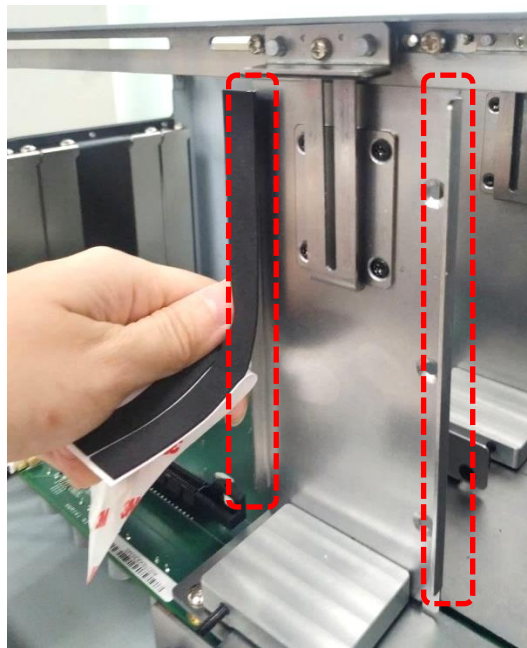

Step 10. Insert GPU card into the PCIe socket.

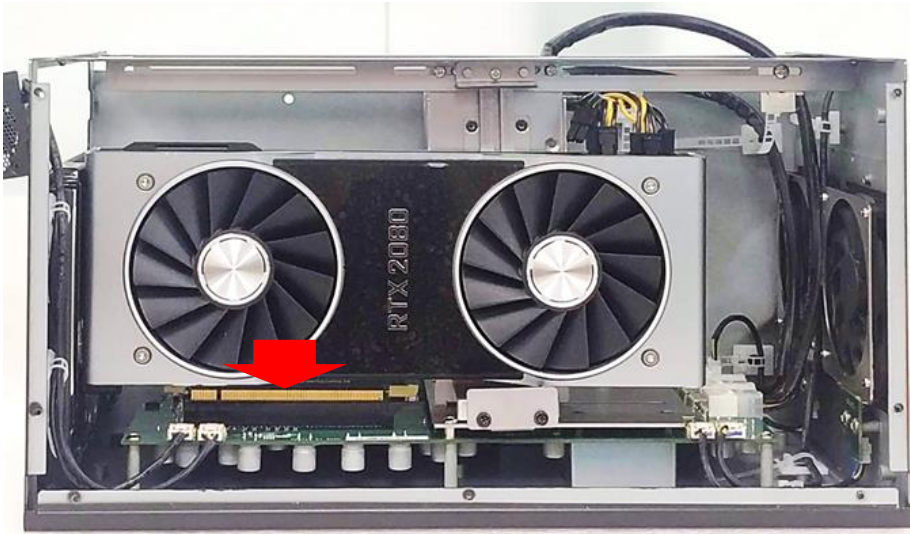

Step 11. Fasten the screws back.



Step 12. Fasten the four screws to fix the card retainer.

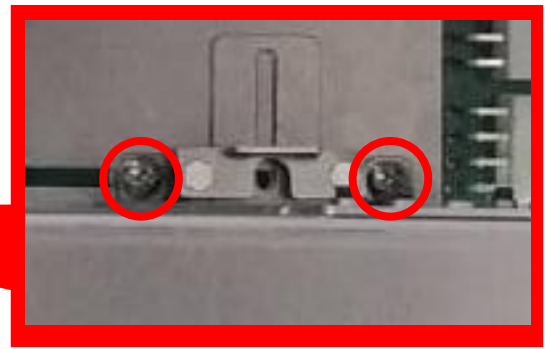
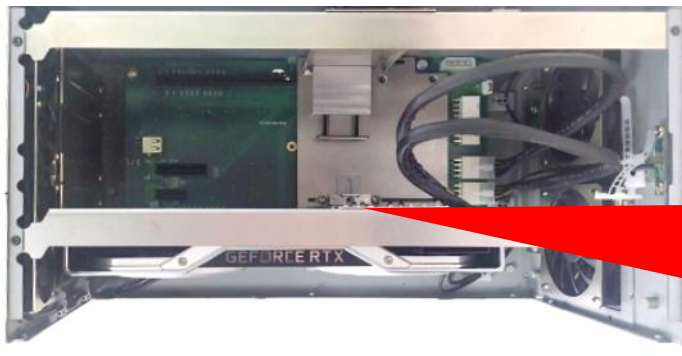

Front View

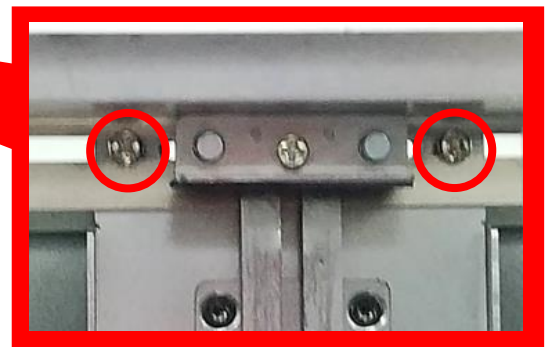
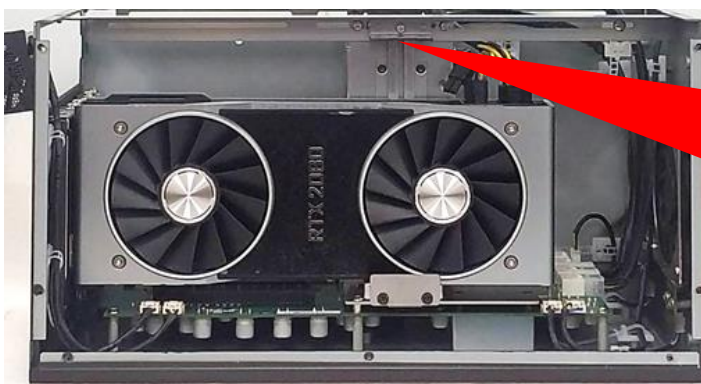

Top View

Step 13. Push the plate till it contacts the GPU card, and then fasten the two screws to fix the GPU card

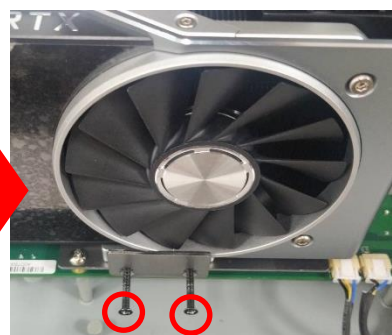
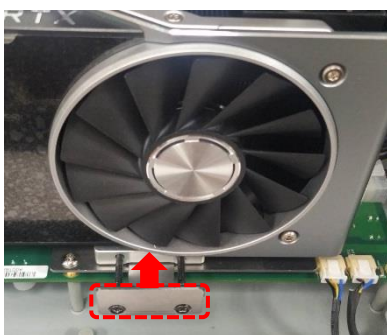

Step 14. Fasten the screw (M3X6L) to fix the card retainer.

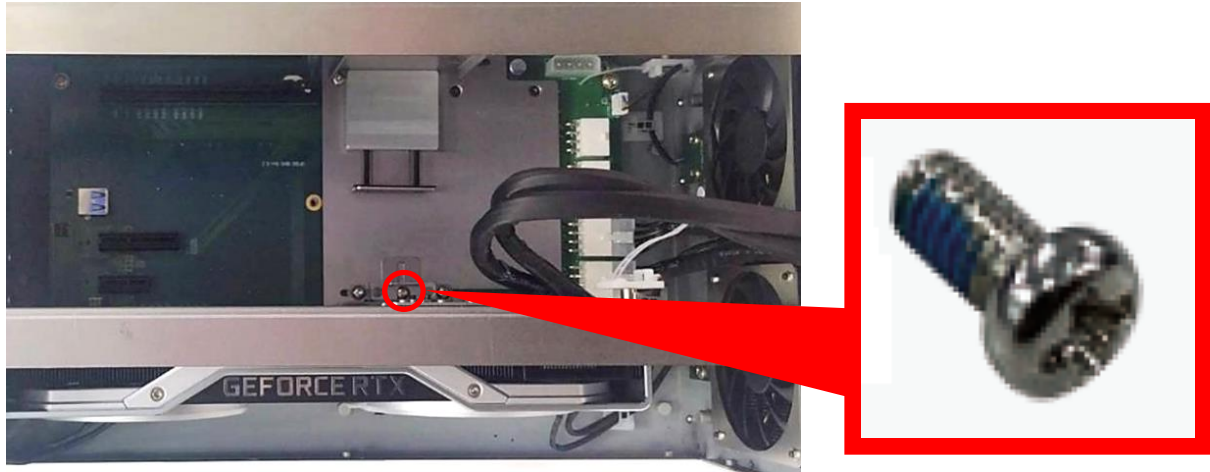

NOTE
(NOTE)

It is normal that the GPU card might be too thick to fasten the screw to the hole.
(Il est normal que la carte GPU puisse être trop épaisse pour fixer la vis dans le trou.)

Step 15. Loosen but not remove the screw.

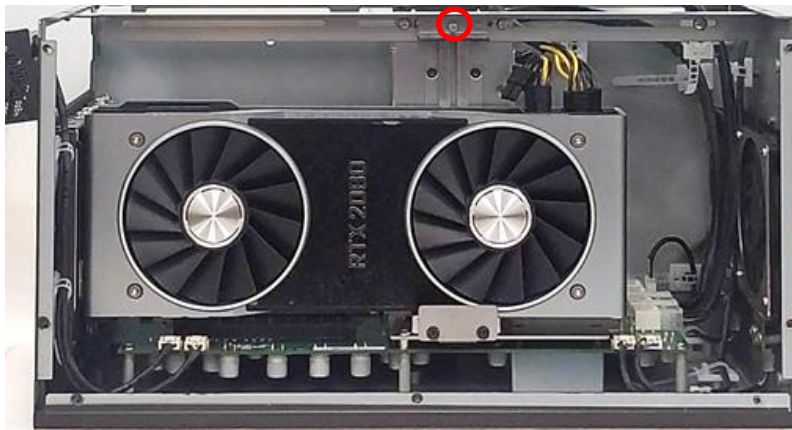

Step 16. Make sure that the metal plate slides down until it touches the GPU card, and then fasten the screw to fix the GPU card.



Step 17. Fasten the screw (M3x5L, included in the Module Pack).

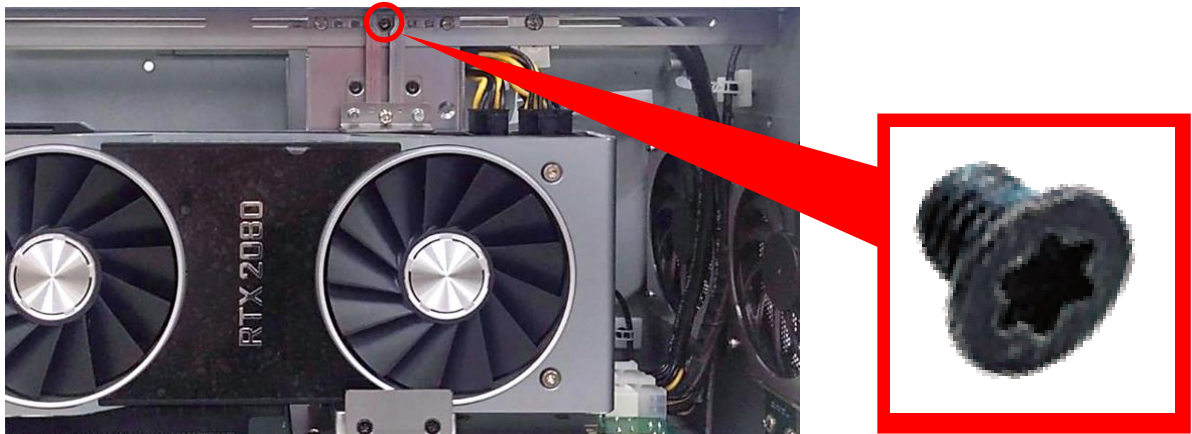

Step 18. Loosen but not remove the screw in order to move the cable tie seat to an appropriate place.



Step 19. Use the cable tie (included in the Module Pack) to tie the two wires together.

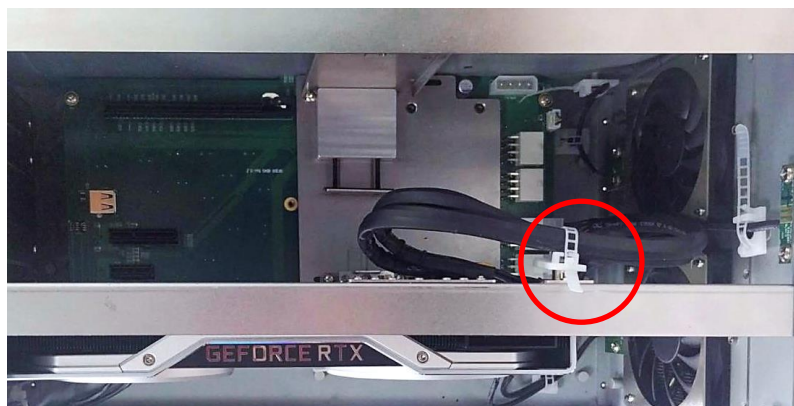

Step 20. Press the wire and tape to close to the fan side and meanwhile push the fan seat back to the module. Fasten the screw and execute the installation step 7~ 8 in chapter 3.21.1 in the end.

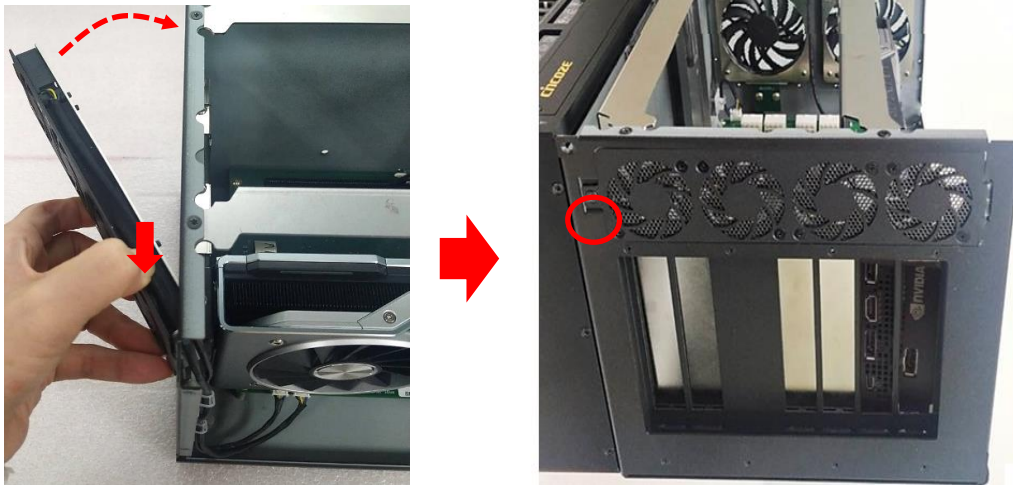

CAUTION
(ATTENTION)

This step is important! Failure to follow this step may scratch and damage the wire. (Cette étape est importante ! Ne pas suivre cette étape pourrait rayer et endommager le fil.)

3.21.3 Installing Rubber Foot Pad

Step 1. Locate the two screw holes on the side panel of GEB-3601.



Step 2. Attach on the two rubber foot pads and fasten the two screws (M4x8L) to fix them.

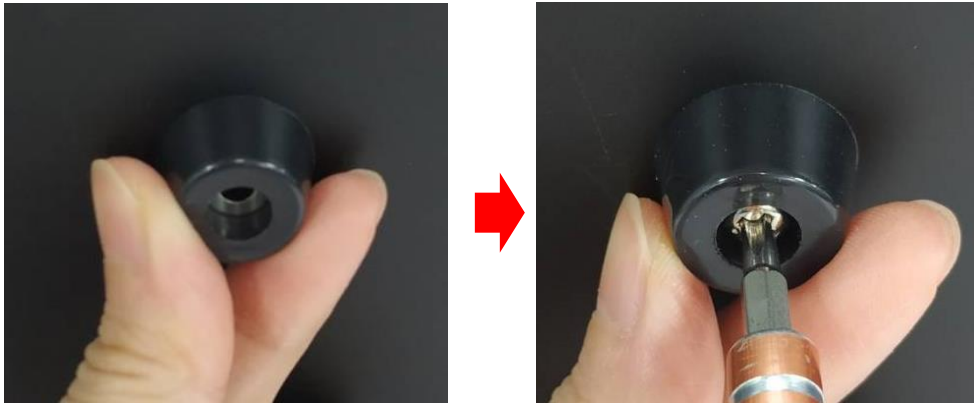

3.21.4 Installing Wall Mount

GP-3100 with GEB-3601 Module provides a wall mount kit that customers can install system on the wall in a convenient and economical way.

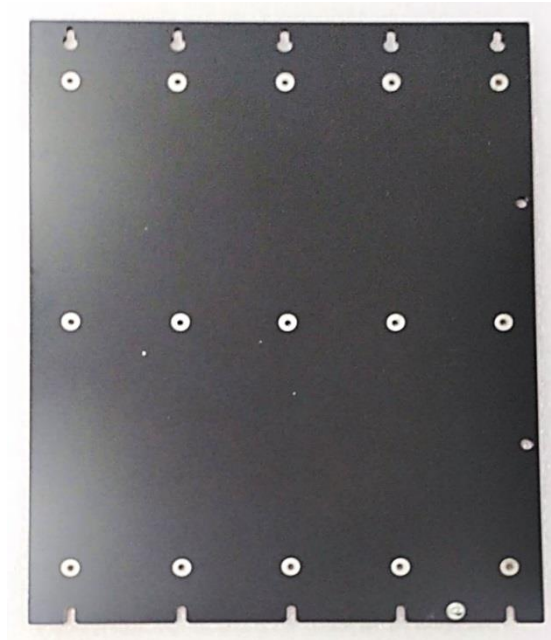

Step 1. After completing all the installation steps in chapter 3.21.1, attach the wall mount bracket onto the system according to the orientation shown below.



Step 2. Use provided 15 screws (M4x8L) to fasten the bracket.

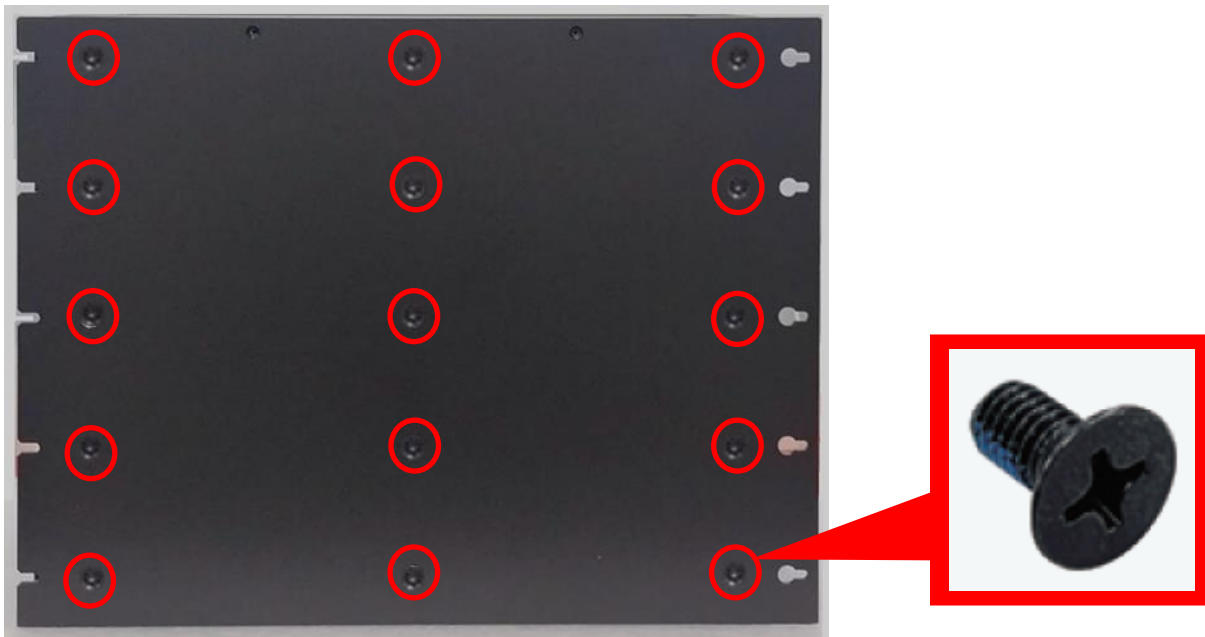

Step 3. The 10 bracket mounting holes are used to fix the system on the wall.



3.21.5 Installing 19" Rack Mount

GP-3100 with GEB-3601 Module provides the 19" Rack Mount kit that customers can install the system onto the 19" Rack.



Before installing GP-3100/GEB-3601 onto the 19" Rack Mount, please follow the steps below to assemble the 19" Rack Mount kit first.

- (1) Locate the four screw holes



- (2) Attach the two handles onto the seat bracket, and fasten the four screws (M5x12L) to fix them from the back side.

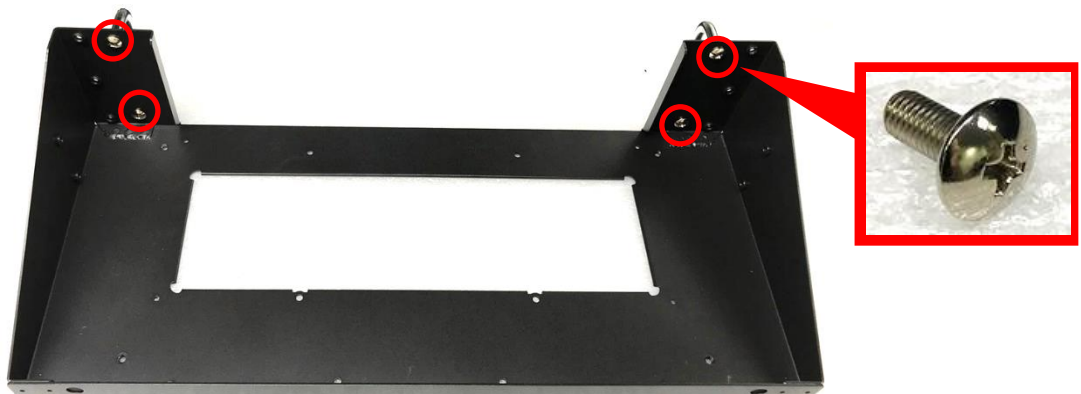

(3) Place the back panel onto the seat bracket as the indicated direction

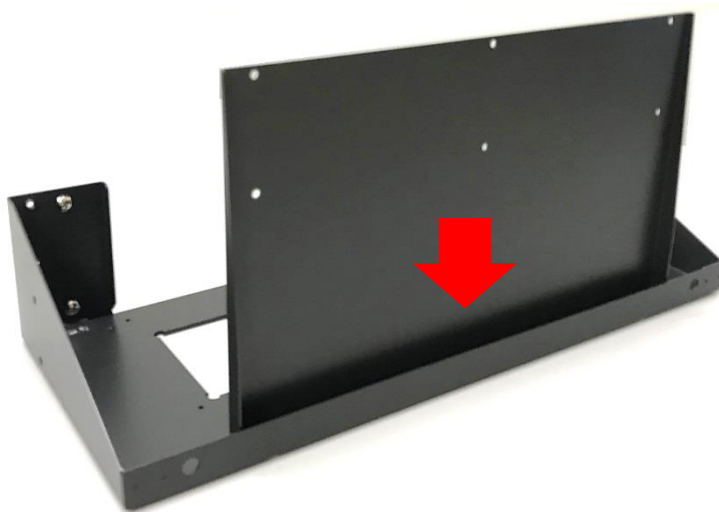

(4) Turn to the bottom side of the seat bracket. Fasten the four screws (M4x6L) to fix the back panel.

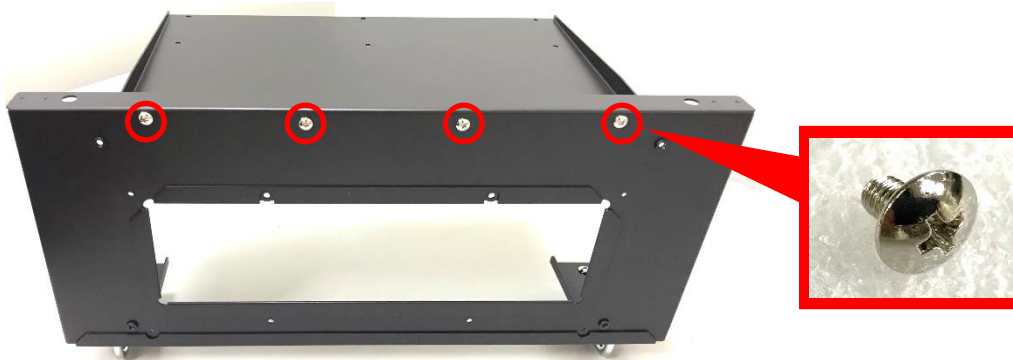

Step 1. Get the assembled GP-3100/GEB-3601 ready. Loosen and remove the four screws on the front panel of the GEB-3601 module.



Step 2. Place the GP-3100/GEB-3601 into the assembled 19" Rack Mount kit.

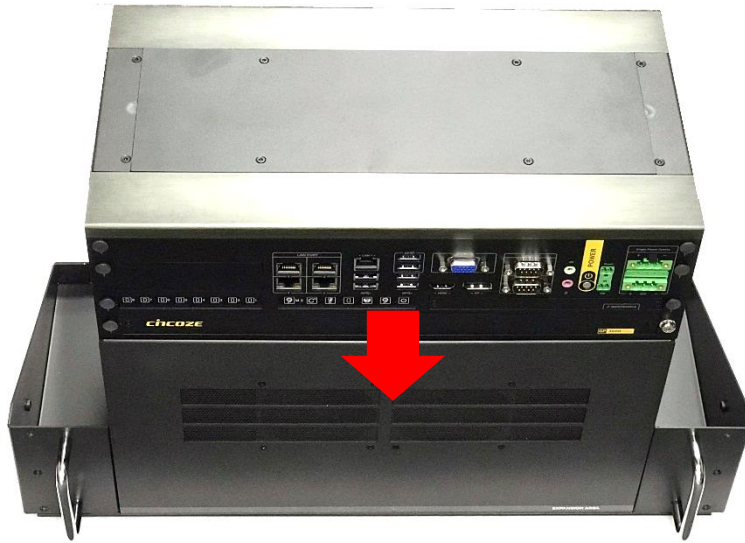

Step 3. Turn to the bottom side of the 19" Rack Mount kit, and fasten the four screws (M3x8L).



Step 4. Turn to the back side of the 19" Rack Mount kit, and fasten the 6 screws (M4x6L).



Step 5. Install the GP-3100/GEB-3601 with the 19" Rack Mount kit onto the 19" Rack by fastening screws as indicated below to complete the installation. (User needs to prepare the screws according to the rack on site)





Chapter 4

BIOS Setup

4.1 BIOS Introduction

The BIOS (Basic Input/ Output System) is a program located on a Flash Memory on the motherboard. When you start the computer, the BIOS program will gain control. The BIOS first operates an auto-diagnostic test called POST (power on self-test) for all the necessary hardware, it detects the entire hardware device and configures the parameters of the hardware synchronization.

BIOS Setup

Power on the computer and by pressing immediately allows you to enter Setup. If the message disappears before your respond and you still wish to enter Setup, restart the system to try again by turning it OFF then ON or pressing <Ctrl>, <Alt> and <Delete> keys.

Control Keys	
<<-> <->>	Move to select screen
<↑> <↓>	Move to select item
<Esc>	Quit the BIOS Setup
<Enter>	Select item
<Page Up/+>	Increases the numeric value or makes changes
<Page Down/->	Decreases the numeric value or makes changes
<Tab>	Select setup fields
<F1>	General help
<F2>	Previous value
<F3>	Load Optimized defaults
<F10>	Save configuration and Exit

Main Menu

The main menu lists the setup functions you can make changes to. You can use the arrow keys (↑ ↓) to select the item. The on-line description of the highlighted setup function is displayed at the bottom of the screen.

Sub-Menu

If you find a right pointer symbol appears to the left of certain fields that means a sub-menu can be launched from this field. A sub-menu contains additional options for a field parameter. You can use arrow keys (↑ ↓) to highlight the field and press <Enter> to call up the sub-menu. Then you can use the control keys to enter values and move from field to field within a sub-menu. If you want to return to the main menu, just press the <Esc >.

4.2 Main Setup

Press to enter BIOS CMOS Setup Utility, the Main Menu (as shown below) will appear on the screen. Use arrow keys to move among the items and press <Enter> to accept or enter a sub-menu.



4.2.1 System Date

Set the date. Please use <Tab> to switch between date elements.

4.2.2 System Time

Set the time. Please use <Tab> to switch between time elements.

4.3 Advanced Setup

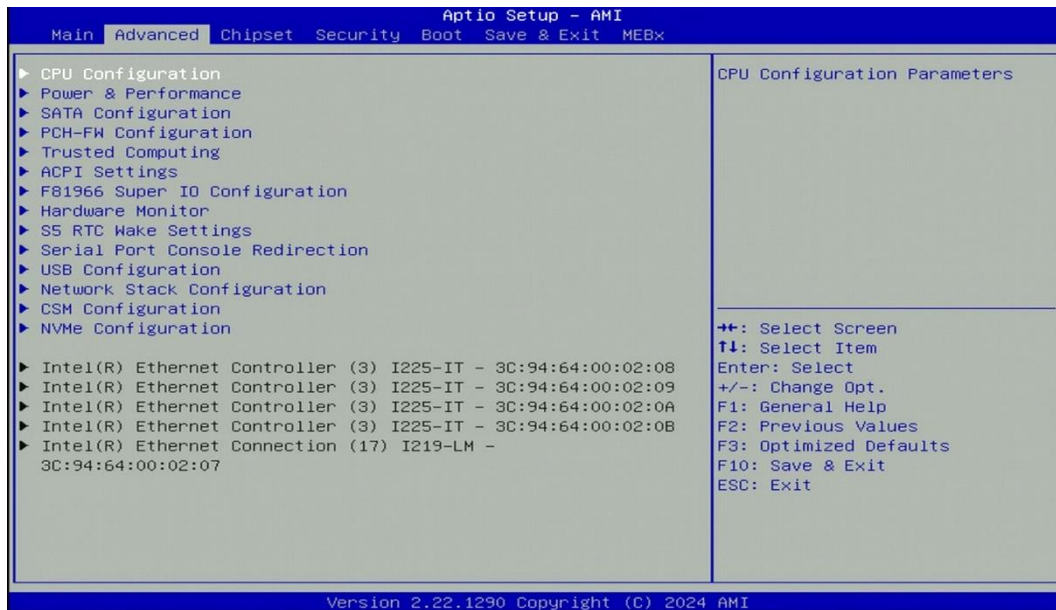

4.3.1 CPU Configuration

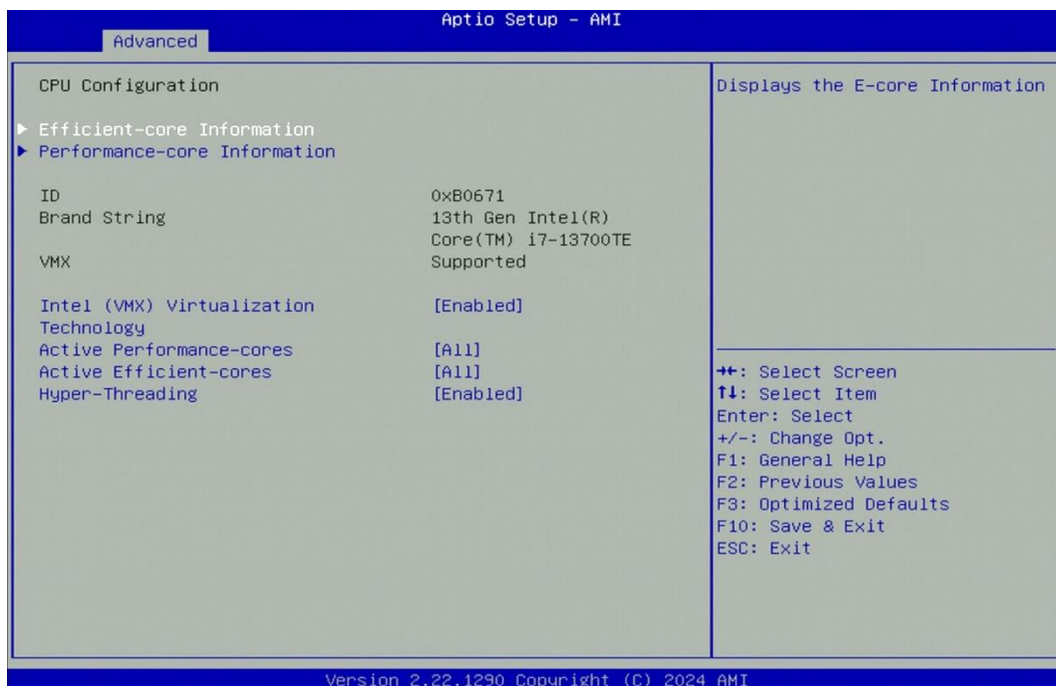

■ Efficient-core Information

This page displays the E-core Information.

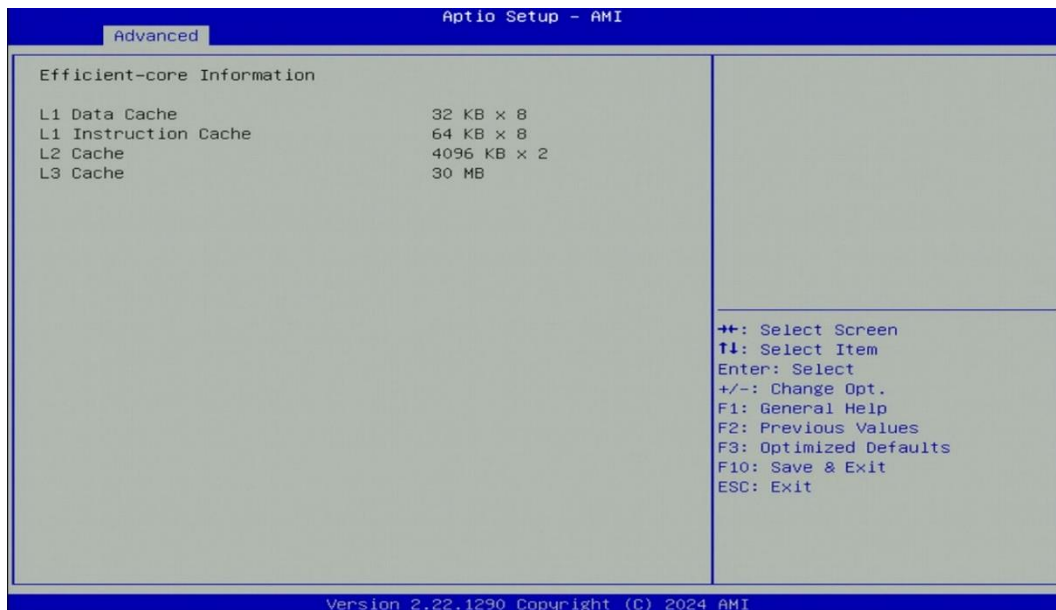

- **Performance-core Information**

This page displays the P-core Information.

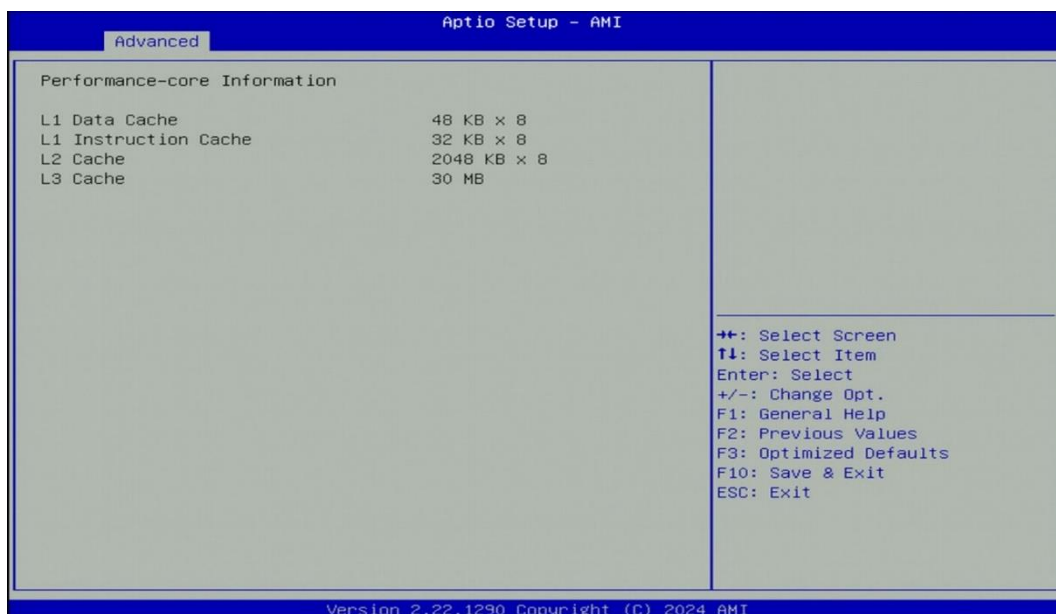

- **Intel (VMX) Virtualization Technology [Enabled]**

Enables or disables Intel Virtualization Technology. Virtualization enhanced by Intel Virtualization Technology will allow a platform to run multiple operating systems and applications in independent partitions. With virtualization, one computer system can function as multiple virtual systems.

- **Active Performance-cores**

Allows you to choose the number of active performance cores.

Configuration options: [All] [7] [6] [5] [4] [3] [2] [1].

- **Active Efficient-cores**

Allows you to choose the number of active efficient cores.

Configuration options: [All] [7] [6] [5] [4] [3] [2] [1] [0].

■ Hyper-threading

Enables or disables for Hyper-Threading Technology.

4.3.2 Power & Performance



■ SKU Power Config [Auto]

Allows users to choose the upper limit of CPU power.

Configuration options: [Auto] [35W]

4.3.3 SATA Configuration

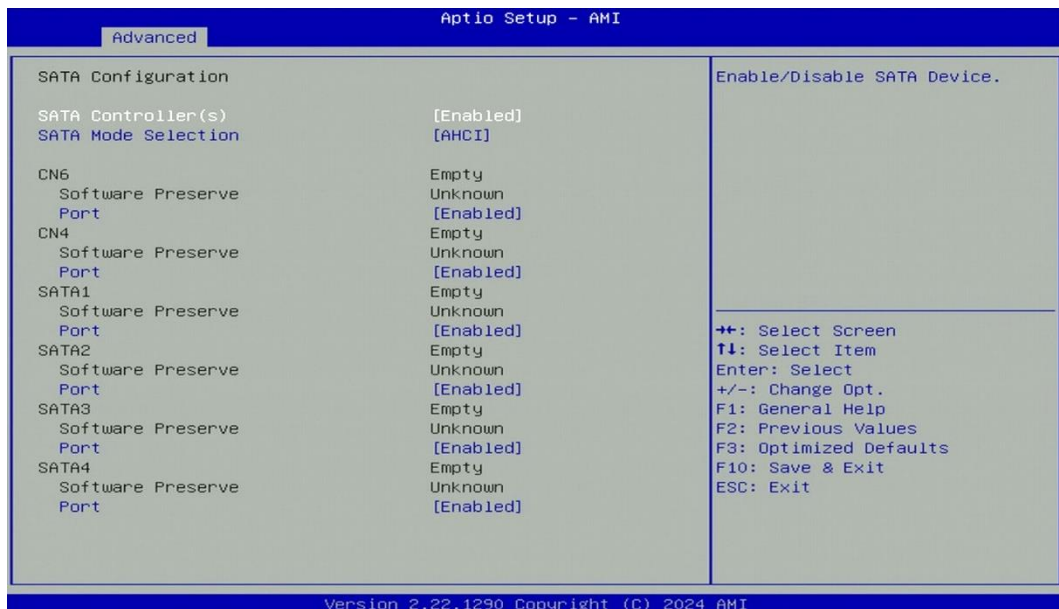

■ SATA Controller(s) [Enabled]

Enables or disables Serial ATA controller.

■ SATA Mode Selection [AHCI]

This item allows users to choose [AHCI] mode only.

- CN6 Port [Enabled]**
Enables or disables CN6 Port.
- CN4 Port [Enabled]**
Enables or disables CN4 Port.
- SATA 1 Port [Enabled]**
Enables or disables SATA 1 Port.
- SATA 2 Port [Enabled]**
Enables or disables SATA 2 Port.
- SATA 3 Port [Enabled]**
Enables or disables SATA 3 Port.
- SATA 4 Port [Enabled]**
Enables or disables SATA 4 Port.

4.3.4 PCH-FW Configuration



■ Firmware Update Configuration



❑ **ME FW Image Re-Flash [Disabled]**

Allows users to enable or disable ME firmware image re-flash function.

4.3.5 Trusted Computing



■ **Security Device Support [Enabled]**

Enables or disables Security Device Support function.

■ **SHA256 PCR Bank [Enabled]**

Enables or disables SHA256 PCR Bank function.

■ **SHA384 PCR Bank [Disabled]**

Enables or disables SHA384 PCR Bank function.

■ **SM3_256 PCR Bank [Disabled]**

Enables or disables SM3_256 PCR Bank function.

■ **Pending Operation [None]**

Allows you to select which mode of Pending Operation will operate.

Configuration options: [None], [TPM Clear]

- **Platform Hierarchy [Enabled]**

Enables or disables Platform Hierarchy function.

- **Storage Hierarchy [Enabled]**

Enables or disables Storage Hierarchy function.

- **Endorsement Hierarchy [Enabled]**

Enables or disables Endorsement Hierarchy function.

- **Physical Presence Spec Version [1.3]**

Allows you to select which mode Physical Presence Spec Version will operate.

Configuration options: [1.2], [1.3]

4.3.6 ACPI Settings

This item allows users to configure ACPI settings.

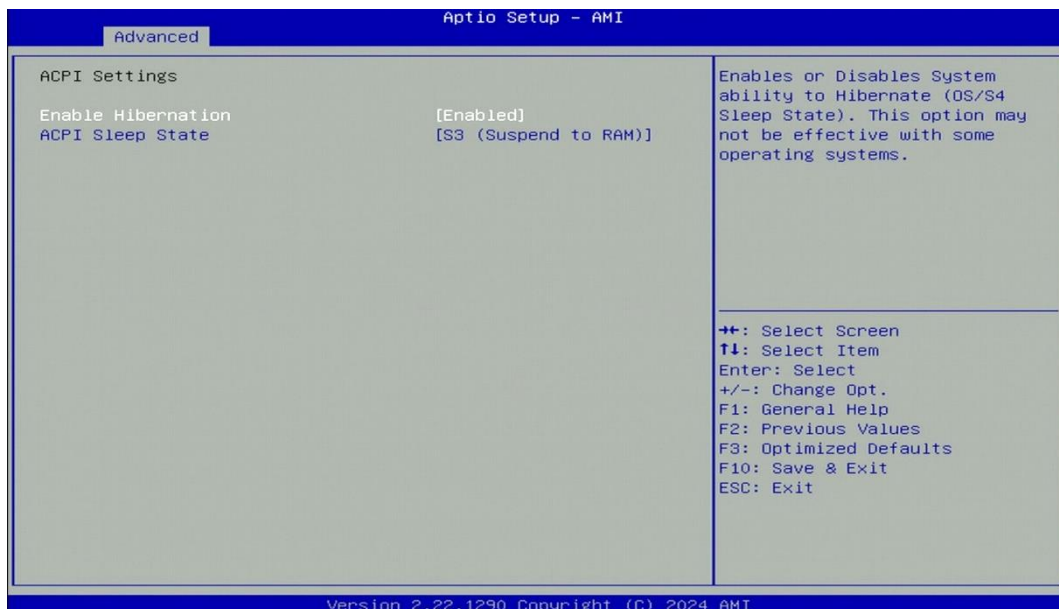

- **Enable Hibernation [Enabled]**

Enables or disables system ability to hibernate state (OS/S4 state). This option may not be effective with some OS.

- **ACPI Sleep State [S3 (Suspend to RAM)]**

Allows users to select the highest Advanced Configuration Power Interface® (ACPI) sleep state that system will enter when suspend button is pressed.

[Suspend Disabled]: Disables entering suspend state.

[S3 (suspend to RAM)]: Enables suspend to RAM state.

4.3.7 F81966 Super IO Configuration

The screen allows users to select options for the Super IO configuration, and change the value of the selected option.

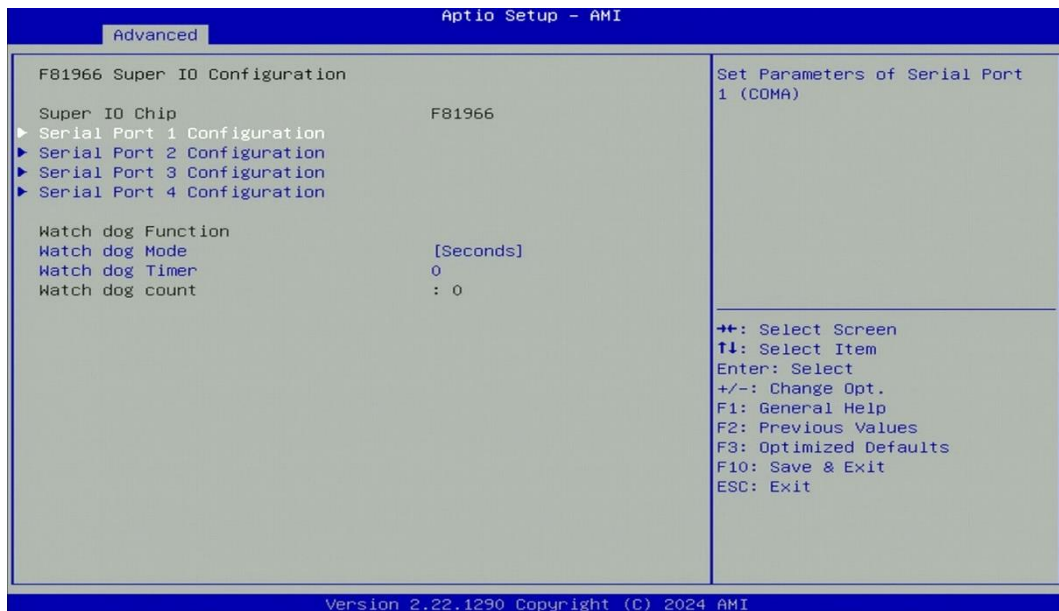

■ Serial Port 1 Configuration



❑ Serial Port [Enabled]

This item allows users to enable or disable serial port.

❑ Change Settings [Auto]

This item allows users to change the address & IRQ settings of the specified serial port.

❑ Onboard Serial Port 1 Mode [RS232]

This item allows users to select Serial Port Mode.

Configuration options: [RS232] [RS422/RS485 Full Duplex] [RS485 Half Duplex]

- **Watch Dog [Disabled]**
Enables or disables watch dog function.
- **Watch Dog Mode [Sec]**
Changes the Watch dog mode. Select [Sec] or [Min] mode.
- **Watch Dog Timer [0]**
User can set a value in the range of 0 to 255.

4.3.8 Hardware Monitor

These items display the current status of all monitored hardware devices/ components such as voltages and temperatures.

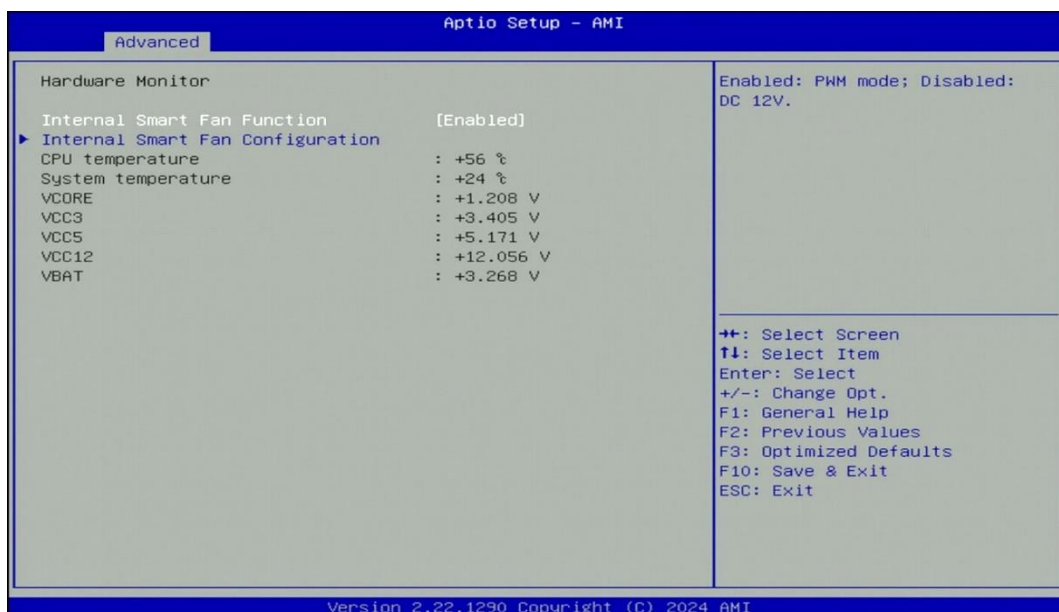

- **Internal Smart Fan Function [Enabled]**
Enables or disables smart fan function.
- **Internal Smart Fan Configuration**
Allows users to setting smart fan parameters.

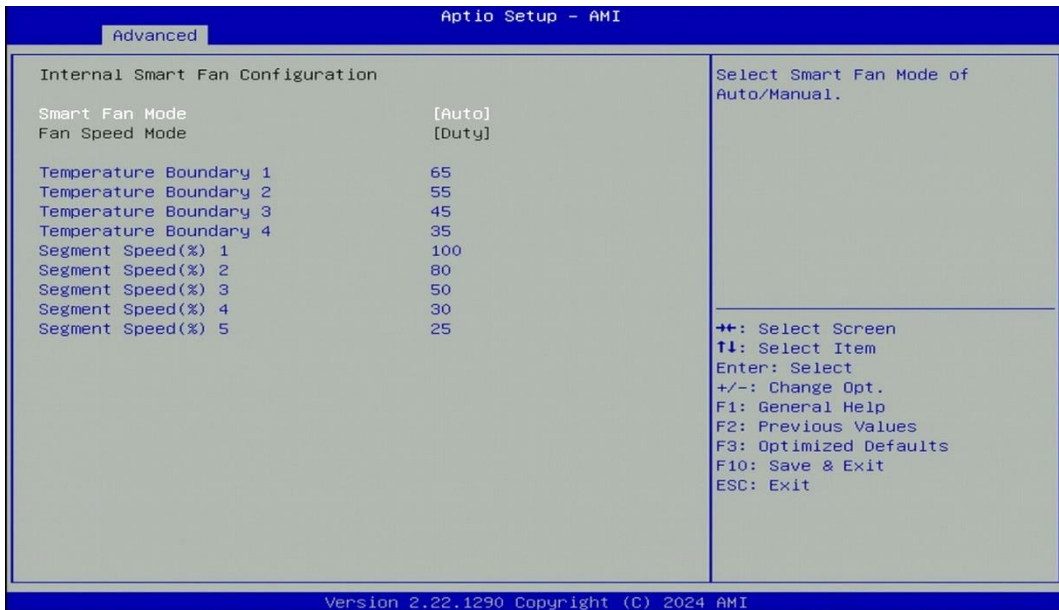

❑ **Smart Fan Mode [Auto]**

Allows you to select Smart Fan Mode.

Configuration options: [Auto] [Manual]

4.3.9 S5 RTC Wake Settings

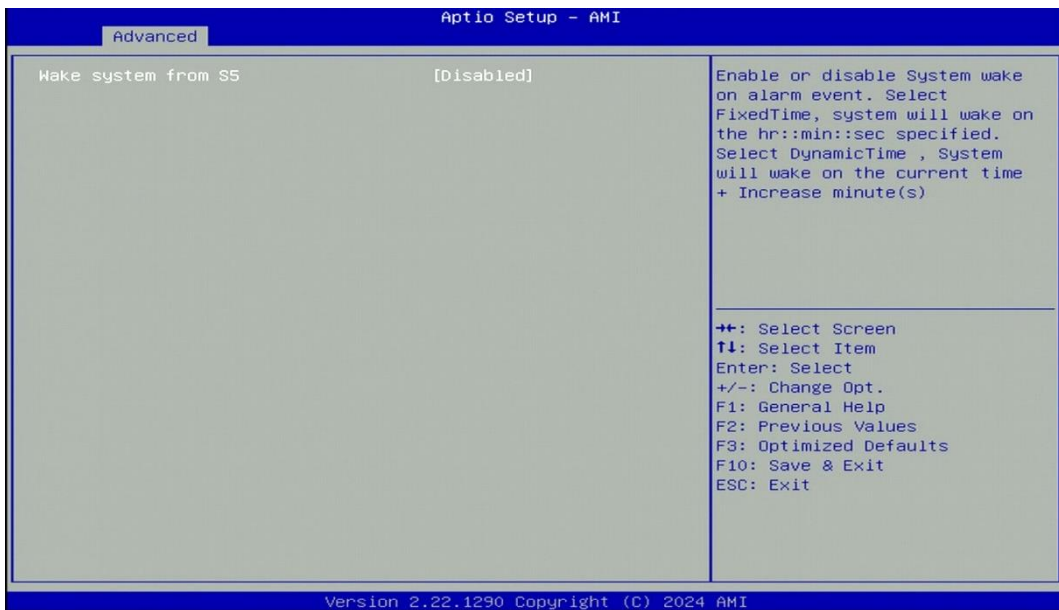

■ **Wake System from S5 [Disabled]**

This item allows users to change the way to wake system from S5 state.

[Fixed Time]: Set the specified time (HH:MM:SS) to wake system.

[Dynamic Time]: Set the increase time from current time to wake system.

4.3.10 Serial Port Console Redirection

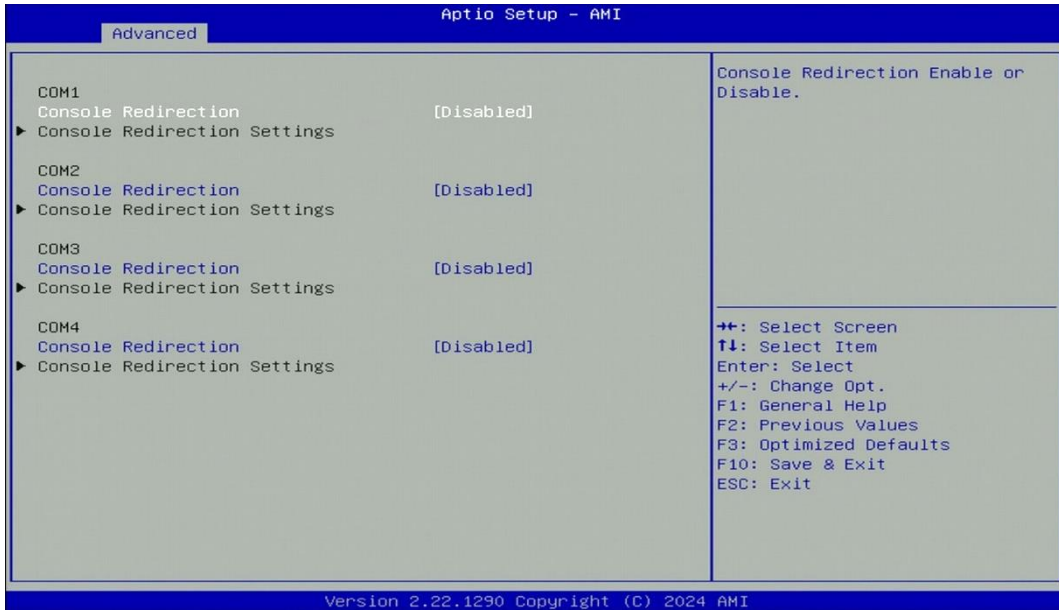

- **Console Redirection [Disabled]**

These items allow users to enable or disable console redirection function.

4.3.11 USB Configuration

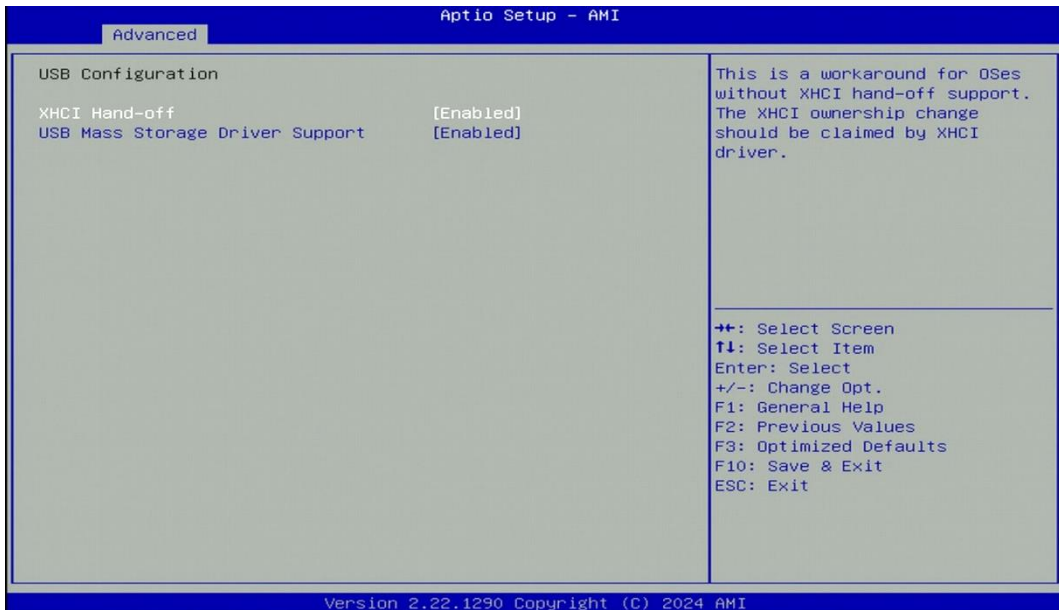

- **XHCI Hand-off [Enabled]**

This item allows users to enable or disable XHCI hand-off function.

- **USB Mass Storage Driver Support [Enabled]**

Enables or disables support for USB mass storage devices.

4.3.12 Network Stack Configuration

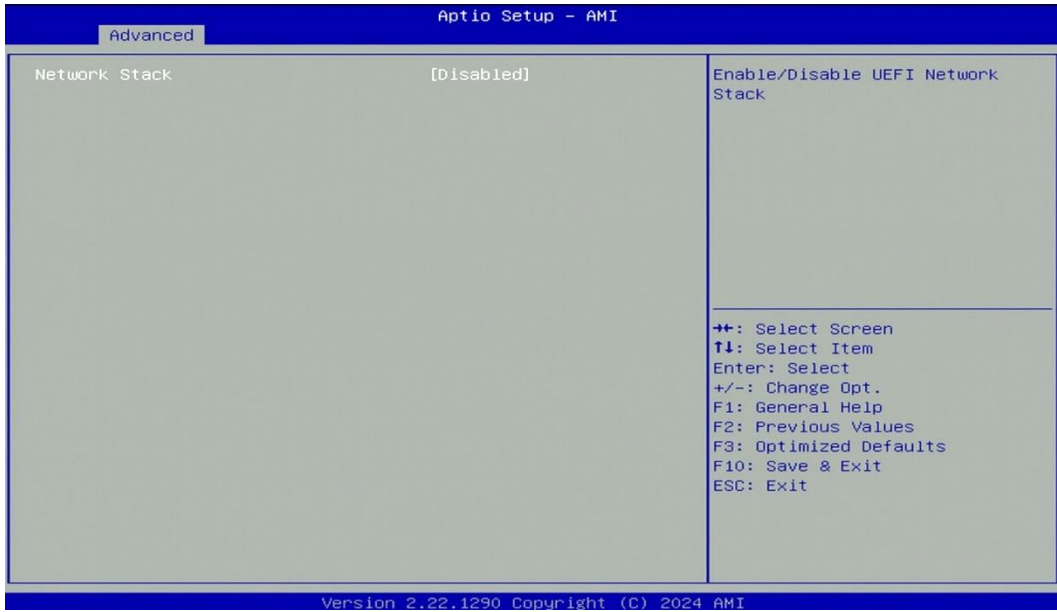

■ Network Stack [Disabled]

Enables or disables UEFI Network Stack.

4.3.13 CSM Configuration



■ CSM Support [Disabled]

Enables or disables compatibility support module.

4.3.14 NVMe Configuration

The screen allows users to select options for the NVMe configuration, and change the value of the selected option. If there is NVMe Device detected, the options will show as the NVMe Device is found.



4.4 Chipset Setup

This section allows you to configure chipset related settings according to user's preference.

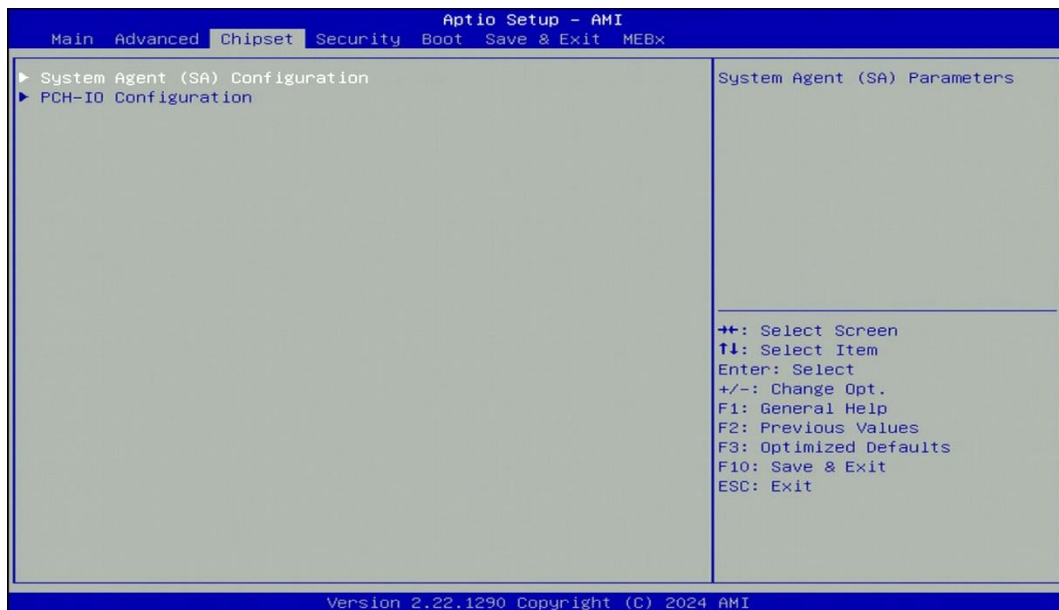

4.4.1 System Agent (SA) Configuration

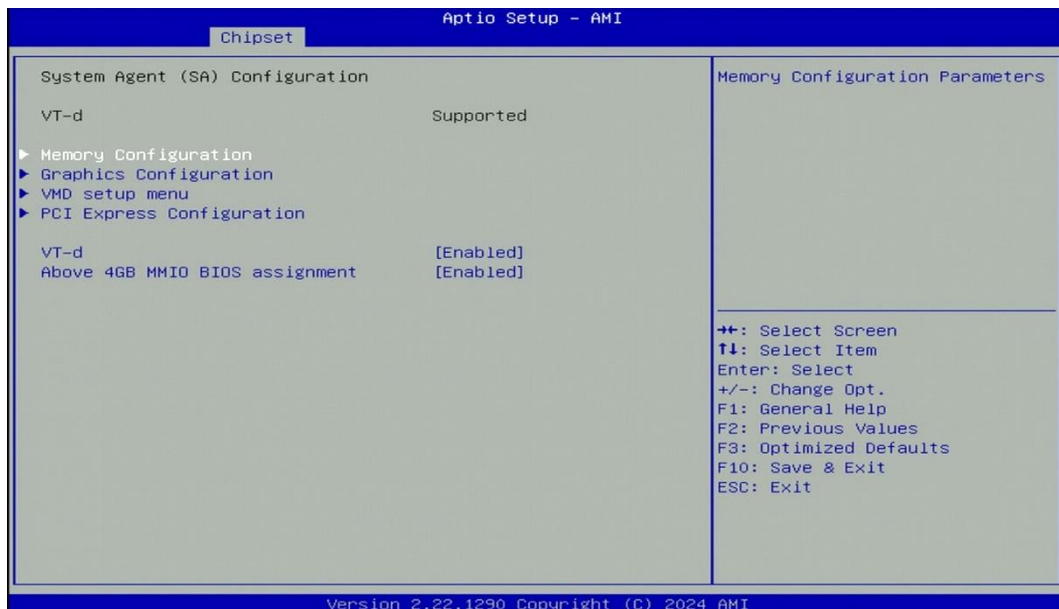

■ Memory Configuration

This item displays detailed memory configuration in the system.

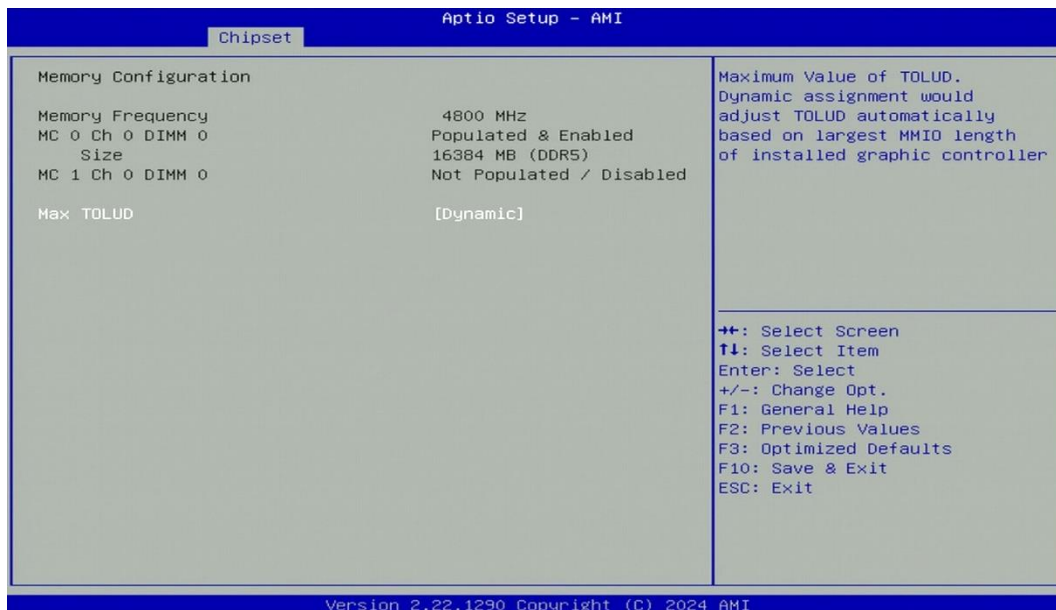

■ Graphics Configuration

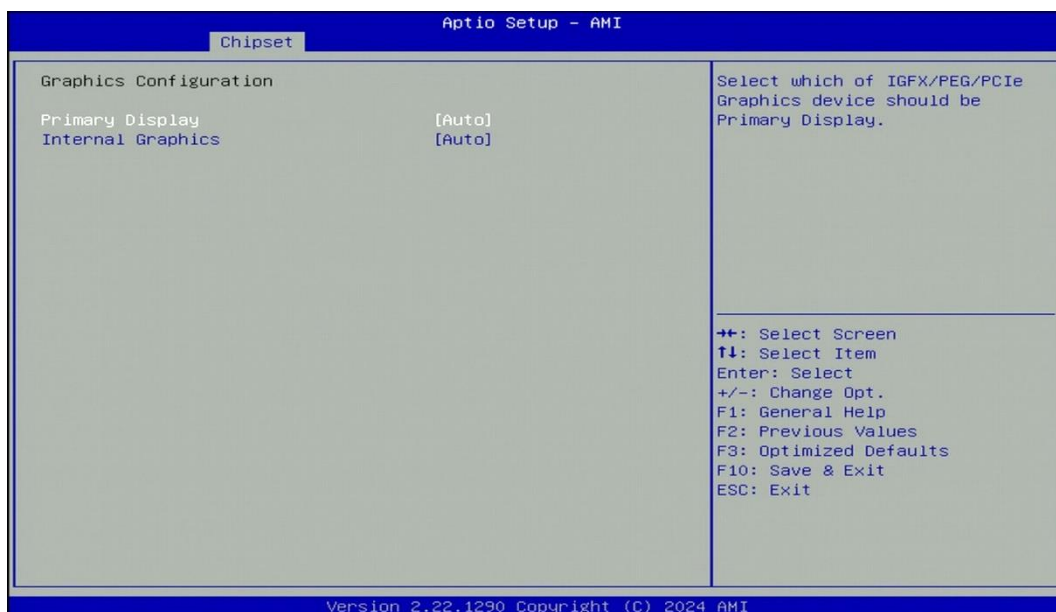

Primary Display [Auto]

Allows users to select which graphics device should be primary display or select SG for switchable graphics.

Configuration options: [Auto] [IGFX] [PEG Slot] [PCIe]

Internal Graphics [Auto]

This item allows users to enable or disable Internal Graphics. When set to [Auto], it will detect by BIOS. Configuration options: [Auto] [Disabled] [Enabled]

■ VMD Configuration



■ Enable VMD controller [Enabled]

Enables or disables VMD controller.

■ PCI Express Configuration

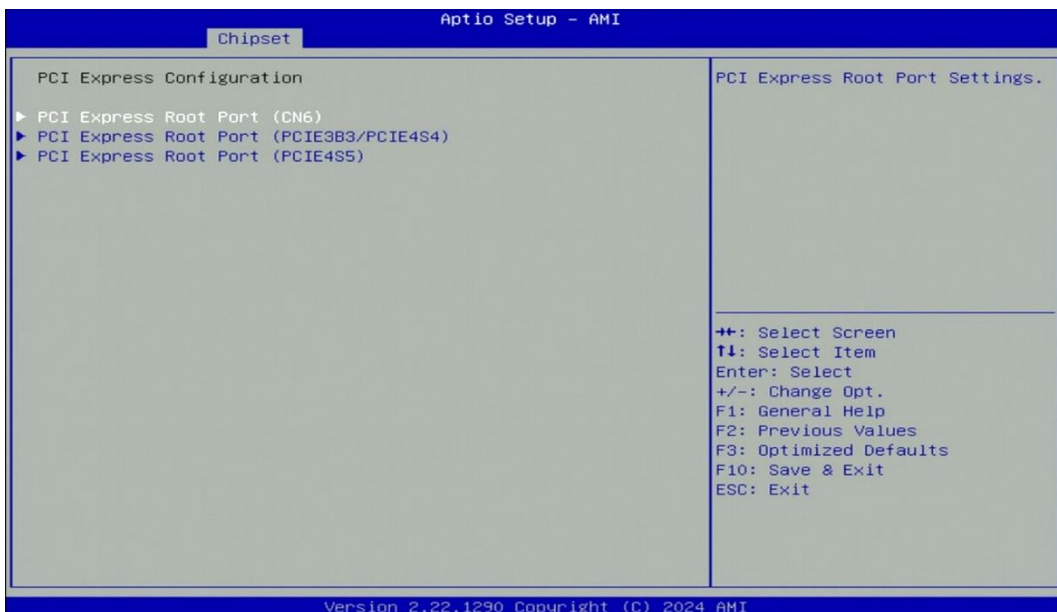

□ PCI Express Root Port (CN6)

■ PCI Express Root Port [Enabled]

Enables or disables PCI Express Root Port.

■ PCIe Speed [Auto]

Allows you to select PCI Express interface speed.

Configuration options: [Auto] [Gen1] [Gen2] [Gen3].

□ PCI Express Root Port (PCIE3B3/PCIE4S4)

- **PCI Express Root Port [Enabled]**

Enables or disables PCI Express Root Port.

- **PCIe Speed [Auto]**

Allows you to select PCI Express interface speed.

Configuration options: [Auto] [Gen1] [Gen2] [Gen3].

- **PCI Express Root Port (PCIe4S5)**

- **PCI Express Root Port [Enabled]**

Enables or disables PCI Express Root Port.

- **PCIe Speed [Auto]**

Allows you to select PCI Express interface speed.

Configuration options: [Auto] [Gen1] [Gen2] [Gen3].

- **VT-d [Enabled]**

This item allows users to enable or disable Intel® Virtualization Technology for Directed I/O (VT-d) function.

- **Above 4GB MMIO BIOS assignment [Enabled]**

This item allows users to enable or disable above 4GB Memory Mapped IO BIOS assignment function.

4.4.2 PCH-IO Configuration

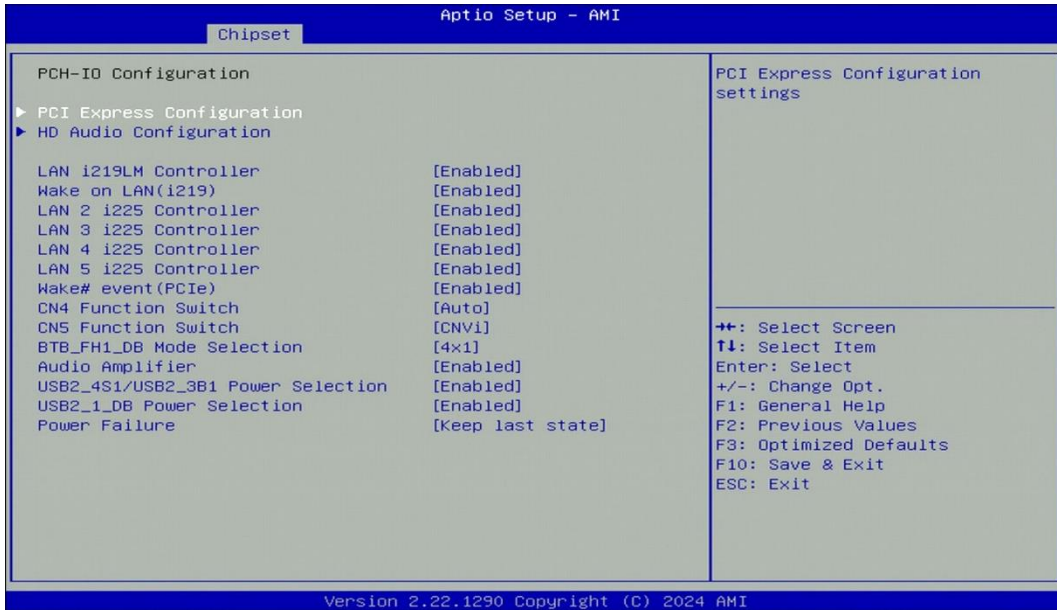

■ PCI Express Configuration

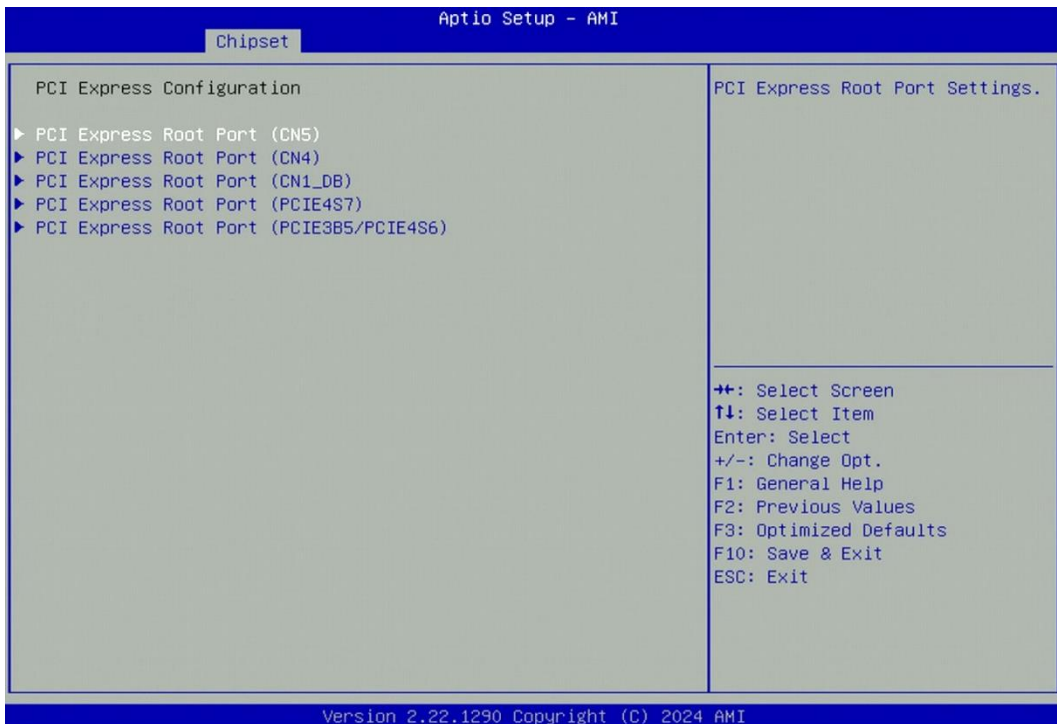

□ PCI Express Root Port (CN5)

■ PCI Express Root Port [Enabled]

Allows you to enable or disable the PCI Express Port.

■ PCIe Speed [Auto]

Allows you to select PCI Express interface speed.

Configuration options: [Auto] [Gen1] [Gen2] [Gen3].

- ❑ **PCI Express Root Port (CN4)**
 - **PCI Express Root Port [Enabled]**
Allows you to enable or disable the PCI Express Port.
 - **PCIe Speed [Auto]**
Allows you to select PCI Express interface speed.
Configuration options: [Auto] [Gen1] [Gen2] [Gen3].
- ❑ **PCI Express Root Port (CN1_DB)**
 - **PCI Express Root Port [Enabled]**
Allows you to enable or disable the PCI Express Port.
 - **PCIe Speed [Auto]**
Allows you to select PCI Express interface speed.
Configuration options: [Auto] [Gen1] [Gen2] [Gen3].
- ❑ **PCI Express Root Port (PCIE4S7)**
 - **PCI Express Root Port [Enabled]**
Allows you to enable or disable the PCI Express Port.
 - **PCIe Speed [Auto]**
Allows you to select PCI Express interface speed.
Configuration options: [Auto] [Gen1] [Gen2] [Gen3].
- ❑ **PCI Express Root Port (PCIE3B5/ PCIE4S6)**
 - **PCI Express Root Port [Enabled]**
Allows you to enable or disable the PCI Express Port.
 - **PCIe Speed [Auto]**
Allows you to select PCI Express interface speed.
Configuration options: [Auto] [Gen1] [Gen2] [Gen3].

■ **HD Audio Configuration**

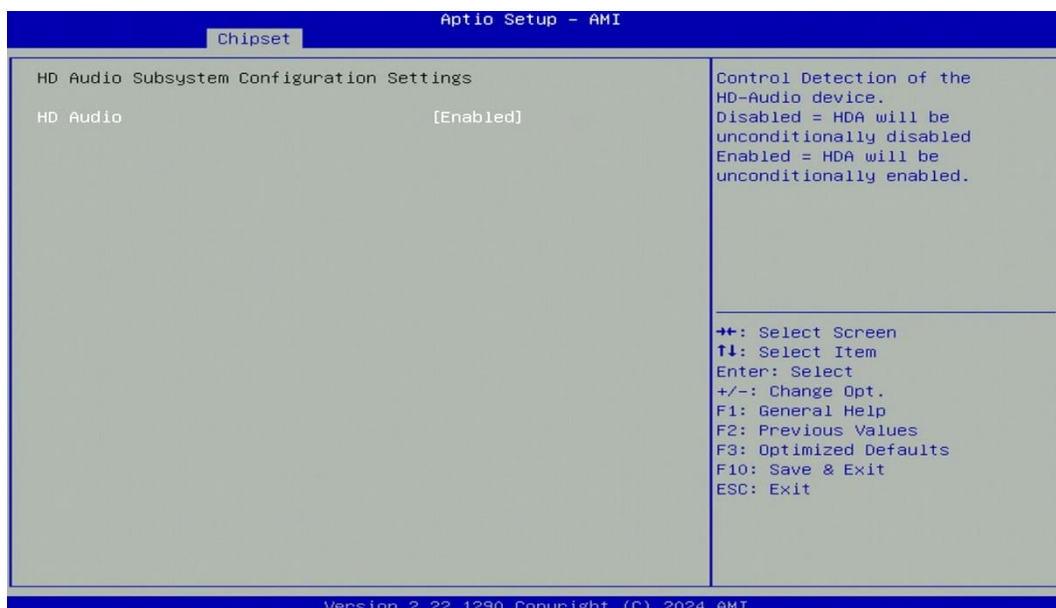

❑ **HD Audio [Enabled]**

Allows you to select HD Audio options.

[Enabled]: HD Audio device is unconditionally enabled.

[Disabled]: HD Audio device is unconditionally disabled.

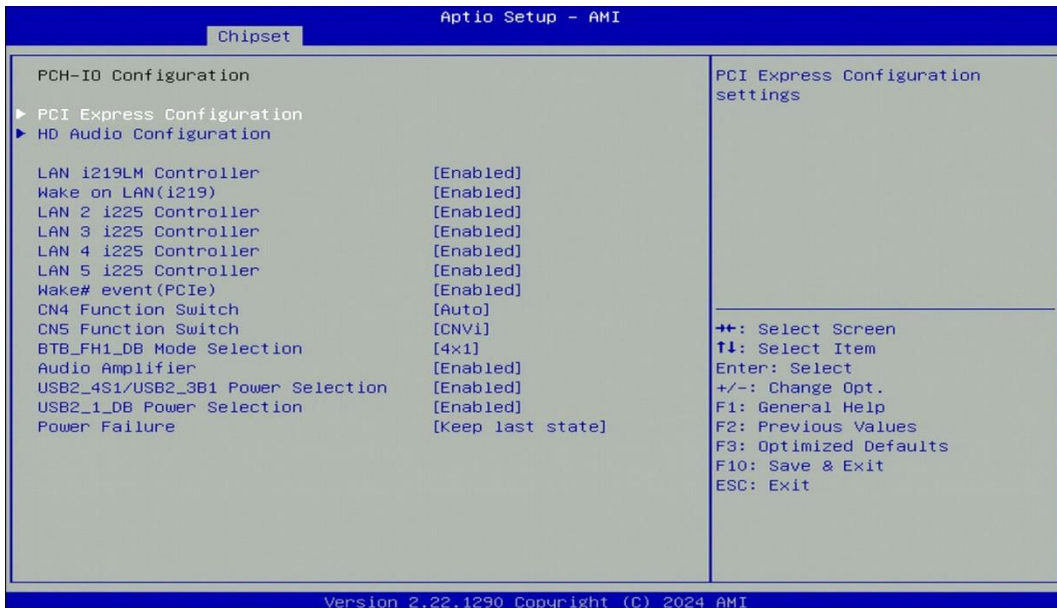

■ **LAN i219LM Controller [Enabled]**

Enables or disables i219LM LAN Controller.

■ **Wake On LAN (i219) [Enabled]**

Enables or disables integrated LAN i219LM Wake on LAN function.

■ **LAN 2 i225 Controller [Enabled]**

Enables or disables LAN 2 i225 Controller.

■ **LAN 3 i225 Controller [Enabled]**

Enables or disables LAN 3 i225 Controller.

■ **LAN 4 i225 Controller [Enabled]**

Enables or disables LAN 4 i225 Controller.

■ **LAN 5 i225 Controller [Enabled]**

Enables or disables LAN 5 i225 Controller.

■ **Wake# event (PCIe) [Enabled]**

Enables or disables Wake on LAN function.

■ **CN4 Function Switch [Auto]**

Allows you to change CN4 Function as [Auto], [SSD-SATA], [SSD-PCIe], [WWAN-PCIe], or [WWAN-USB3].

■ **CN5 Function Switch [CNVi]**

Allows users to select [CNVi] or [WiFi] for CN5 connector.

■ **BTB_FH1_DB Mode Selection [4x1]**

Allows users to select [4x1] or [1x4] for BTB_FH1_DB Mode.

■ **Audio Amplifier [Enabled]**

Enables or disables Audio Amplifier Function.

■ **USB2_4S1/USB2_3B1 Power Selection [Enabled]**

Enables or disables USB2_4S1/USB2_3B1 Function.

■ **USB2_1_DB Power Selection [Enabled]**

Enables or disables USB2_1_DB Function.

■ **Power Failure [Keep last state]**

Allows you to specify which power state system will enter when power is resumed after a power failure (G3 state).

[Always on]: Enters to power on state.

[Always off]: Enters to power off state.

[Keep last state]: Enters to the last power state before a power failure.

4.5 Security Setup

This section allows users to configure BIOS security settings.

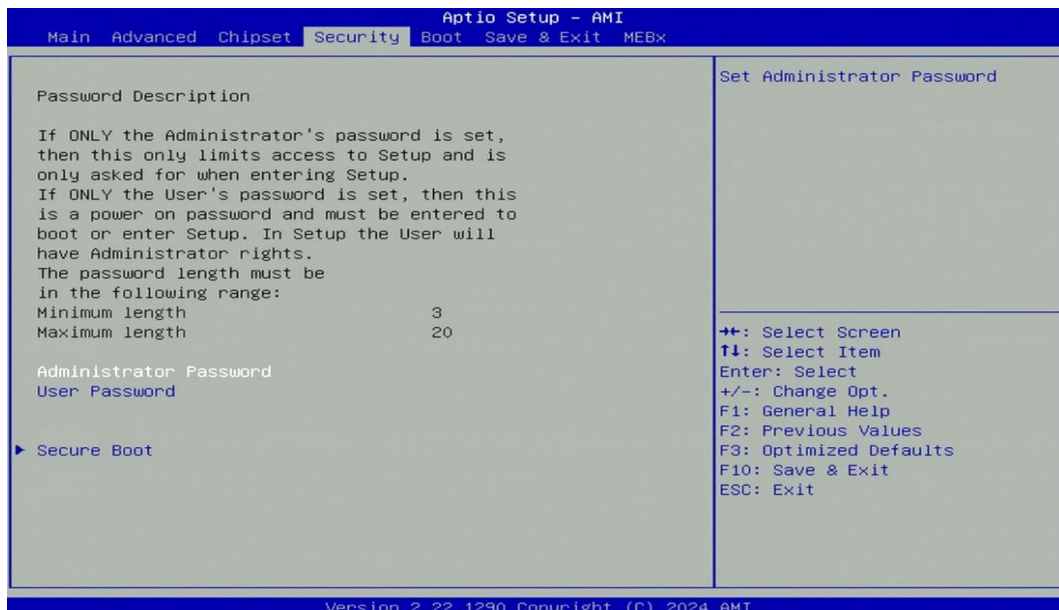

4.5.1 Administrator Password

Administrator Password controls access to the BIOS Setup utility.

4.5.2 User Password

User Password controls access to the system at boot and to the BIOS Setup utility.

4.5.3 Security Boot

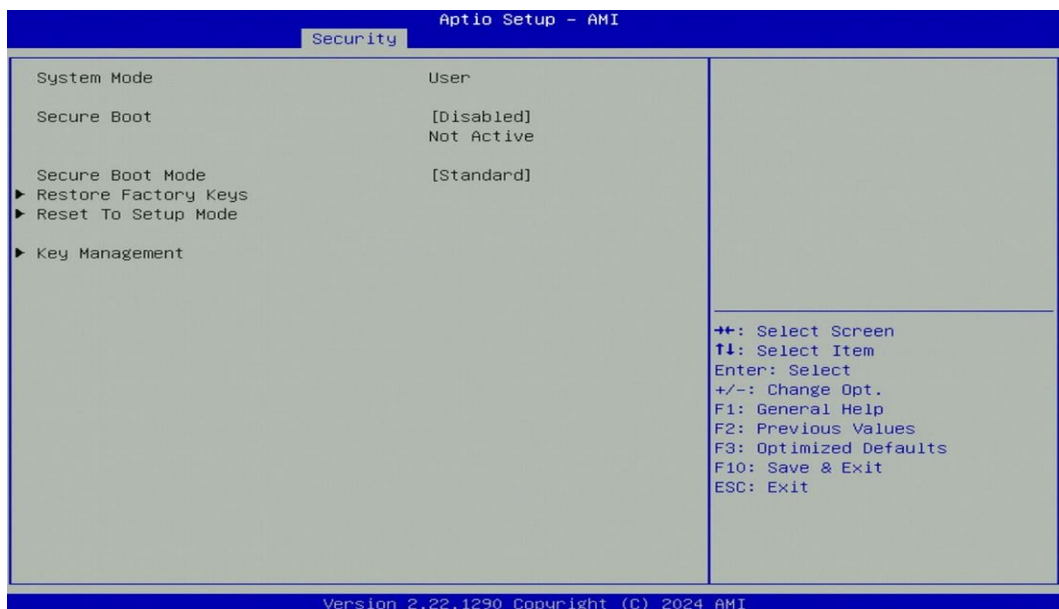

4.6 Boot Setup

This section allows you to configure Boot settings.

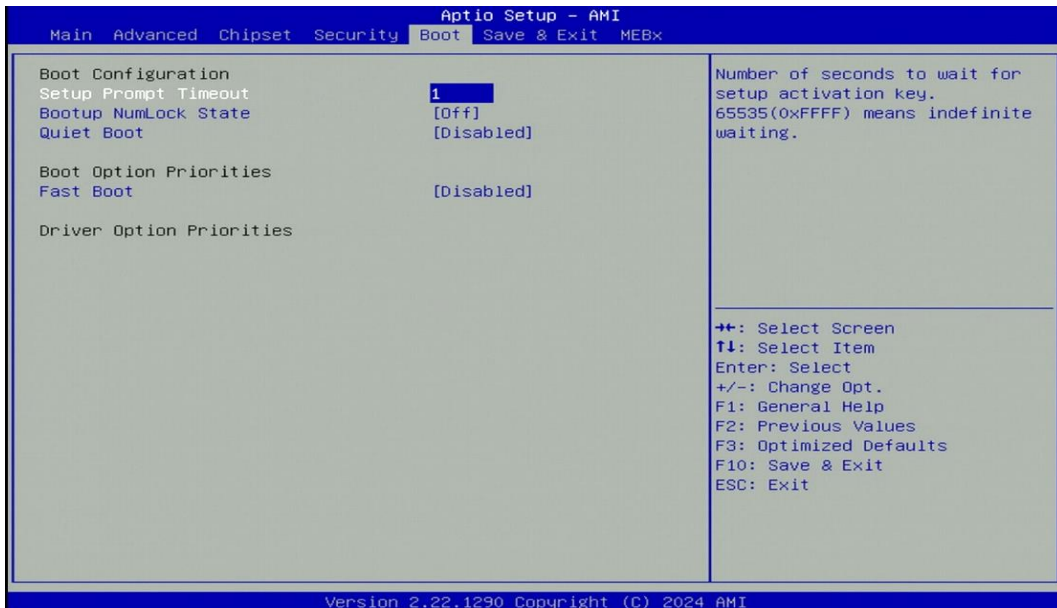

4.6.1 Setup Prompt Timeout [1]

Use this item to set number of seconds (1..65535) to wait for setup activation key.

4.6.2 Bootup NumLock State [Off]

Allows users to select the power-on state for keyboard NumLock.

4.6.3 Quiet Boot [Disabled]

Allows users to enable or disable Quiet Boot function.

4.6.4 Fast Boot [Disabled]

Allows users to enable or disable Fast Boot function.

4.7 Save & Exit

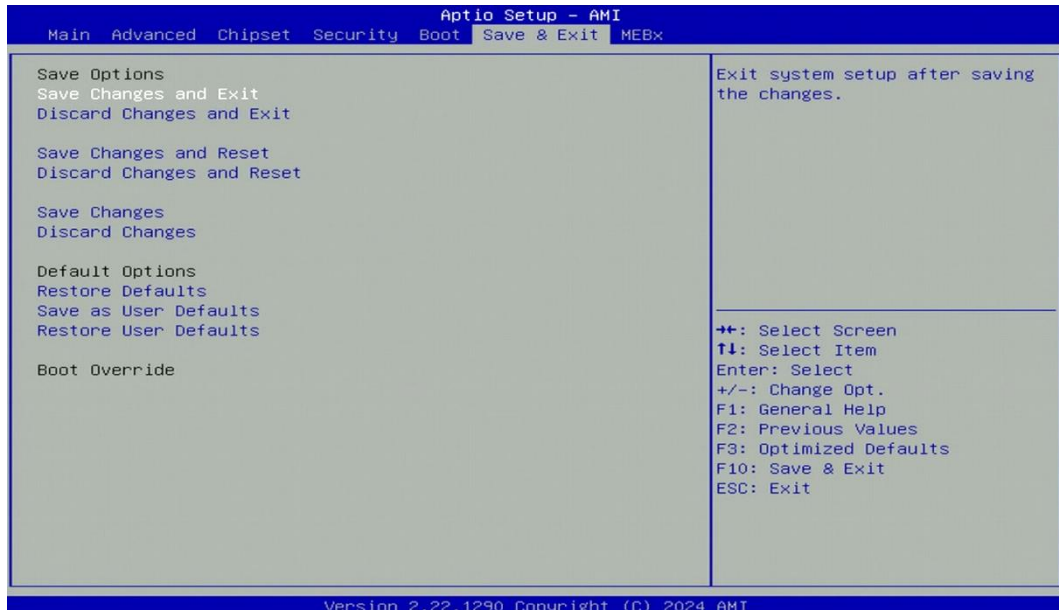

4.7.1 Save Changes and Exit

This item allows users to exit system setup after saving changes.

4.7.2 Discard Changes and Exit

This item allows users to exit system setup without saving changes.

4.7.3 Save Changes and Reset

This item allows users to reset the system after saving changes.

4.7.4 Discard Changes and Reset

This item allows users to reset system setup without saving any changes.

4.7.5 Save Changes

This item allows users to save changes done so far to any of the setup options.

4.7.6 Discard Changes

This item allows users to discard changes done so far to any of the setup options.

4.7.7 Restore Defaults

This item allows users to restore/ load default values for all the options.

4.7.8 Save as User Defaults

This item allows users to save the changes done so far as user defaults.

4.7.9 Restore User Defaults

This item allows users to restore the user defaults to all the options.

4.8 MEBx

This page is dedicated to configuring the ME function. After the system powers on, press the delete key promptly to access the BIOS menu, allowing users to view the following MEBx page.



Press enter key to enter the default password "admin" to enter the next step for password creation.

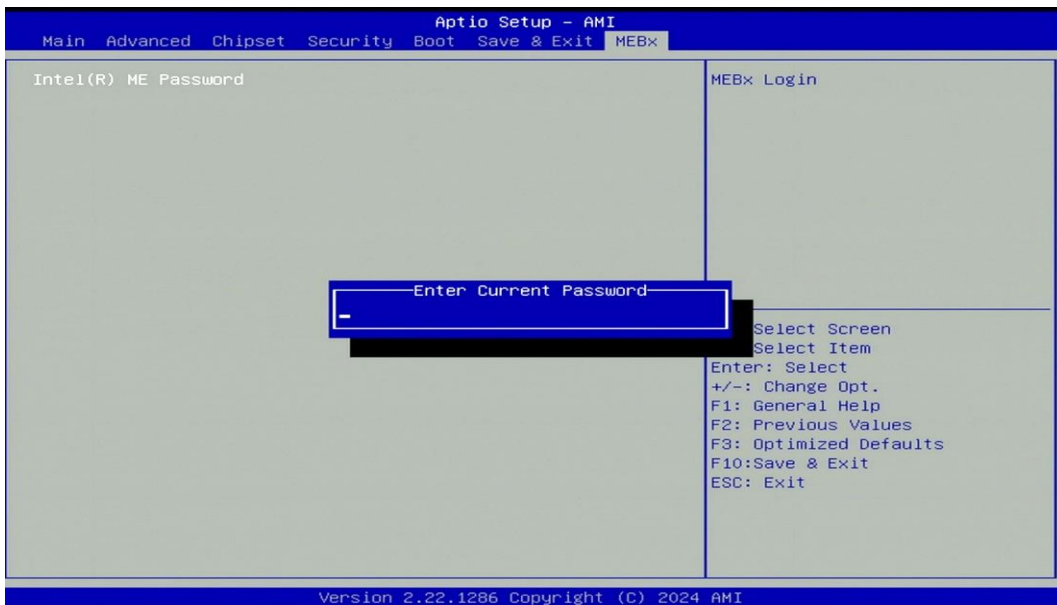

Create a new password using 8 characters including uppercase and lowercase letters, numbers and special symbols. (For example, "Abc123!!")

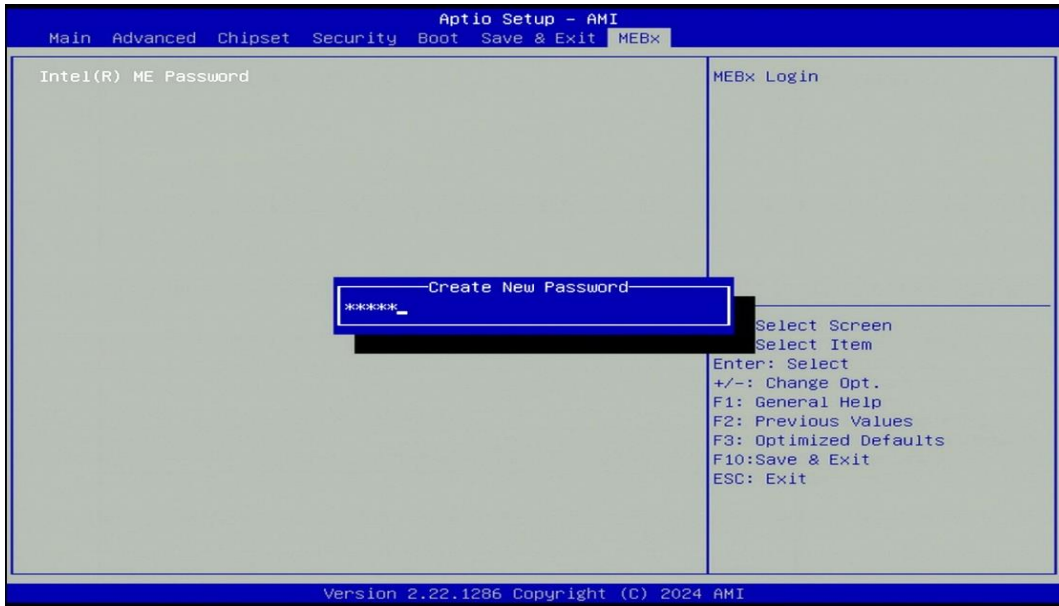

Enter the created password again for confirmation.

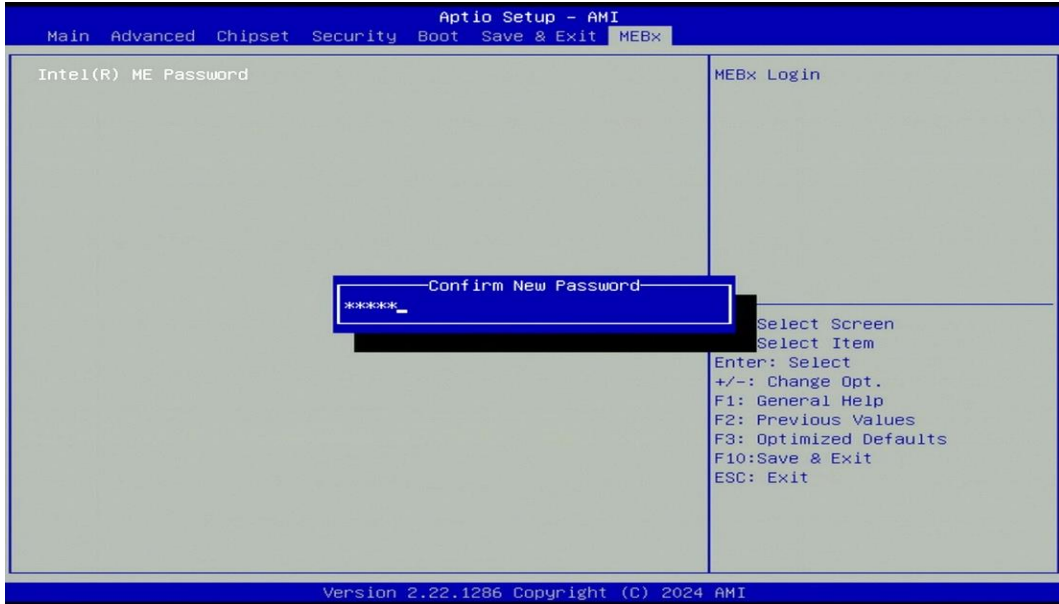

Afterward, you will be directed to the MEBx function setting page."

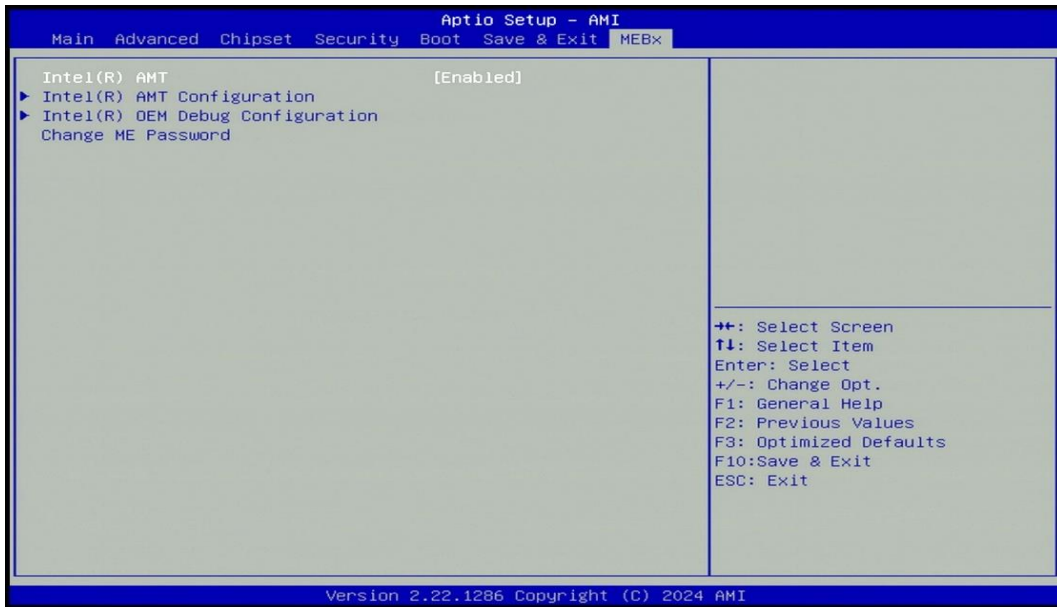



Chapter 5

Product Application

5.1 Where to download drivers?

Drivers for the GP-3100 Series can be downloaded from the CINCOZE website.

5.2 Where to find the technical documents?

The following documents are the most relevant technical references for the GP-3100 Series. All documents can be accessed via the CINCOZE Partner Zone:

- **Application Notes:** Navigate to *Home > Partner Zone > Technical Support > Application Notes*.
- **Configure & Installation:** Navigate to *Home > Partner Zone > Technical Support > Configure & Installation*.
- **Other Product Information:** Navigate to *Home > Partner Zone > Product Center > Product Information > GPU Embedded Computers > Dual Full-length GPU Expandable Computer > GP-3100 Series*.

Catalog	Document Title
Application Notes	DIO Application Guide
	DIO Technical Guide
	Instant Reboot Application Guide
	WDT Application Guide
	WDT Technical Guide
Configure & Installation	AT ATX Function Manual
	BIOS Administrator User Password Function Manual
	Clear CMOS Function Manual
	COM Function Manual
	CSM Function Manual
	Digital I/O Function Manual
	How to import Secure Boot Key?
	How to restore Windows image with Clonezilla?
	How to set TPM function under Windows?
	How to stop automatic driver update in Windows SOP
	How to Update BIOS and ME under UEFI shell?
	How to Update BIOS under UEFI shell?
	How to Update BIOS under Windows?
	IGN Module User Manual
	Intel AMT with KVM Remote Control
	POE Module User Manual
PXE Function Manual	
RAID Function Manual	

	Remote Switch Function Manual
	Wake On LAN Function Manual
	WDT Function Manual

cincoze

© 2024 Cincoze Co., Ltd. All rights reserved.

The Cincoze logo is a registered trademark of Cincoze Co., Ltd.

All other logos appearing in this catalog are the intellectual property of the respective company, product, or organization associated with the logo.

All product specifications and information are subject to change without notice.