

chcoze

GM-1100

User Manual



Embedded GPU Computing System

14/13/12th Gen Intel® Core™ Series Embedded GPU Computer,
Supports 1x MXM 3.1 GPU Expansion Socket

Contents

Preface	5
Revision.....	5
Copyright Notice	5
Acknowledgement	5
Disclaimer	5
Declaration of Conformity	5
Product Warranty Statement	6
Technical Support and Assistance	7
Conventions Used in this Manual	8
Safety Precautions	8
Package Contents.....	9
Ordering Information.....	10
Chapter 1 Product Introductions	11
1.1 Overview	12
1.2 Hardware Specification.....	15
1.3 External Layout	20
1.3.1 Front.....	20
1.3.2 Rear	20
1.4 Dimensions.....	21
Chapter 2 Switches & Connectors	22
2.1 Location of Switches and Connectors.....	23
2.2 Switches and Connectors Definition.....	24
2.3 Switches Definition	25
2.4 Definition of Connectors.....	28
2.5 Optional Module: Definition of Switches and Connectors	33
2.5.1 CMI-LAN01	33
2.5.2 CMI-M12LAN01.....	34
2.5.3 CMI-2P5GLAN01.....	34
2.5.4 CMI-10GXM12LAN01	34
2.5.5 CMI-XM12LAN01.....	35
2.5.6 CMI-10GLAN01.....	35
2.5.7 CMI-COM01.....	35
2.5.8 CMI-CAN01.....	36
2.5.9 CMI-DIO01.....	37
2.5.10 CFM-IGN01	38
Chapter 3 System Setup	39
3.1 Removing Top Cover	40
3.2 Installing CPU	42

3.3 Installing SO-DIMM.....	47
3.4 Installing M.2 Key B Module	48
3.4.1 M.2 Key B type 3052 Socket.....	48
3.4.2 M.2 Key B type 2242 Socket.....	50
3.5 Installing M.2 Key E Module	51
3.5.1 M.2 Key E type 2230 Socket.....	51
3.6 Installing Antenna.....	52
3.7 Installing Antenna Cutout Universal Bracket.....	54
3.7.1 Front Panel	54
3.7.2 Rear Panel	55
3.8 Installing MXM Module	56
3.9 Removing Maintenance Area Panel.....	59
3.10 Installing 2.5" SATA HDD/SSD	60
3.11 Installing M.2 Key M Module.....	62
3.12 Installing SIM Card	63
3.13 Installing CMI Module.....	64
3.13.1 CMI-LAN01/UB1312.....	64
3.13.2 CMI-2P5GLAN01/UB1312	66
3.13.3 CMI-10GXM12LAN01/UB1337	69
3.13.4 CMI-M12LAN01/UB1310	74
3.13.5 CMI-XM12LAN01/UB1330	76
3.13.6 CMI-10GLAN01/UB1328	78
3.13.7 CMI-CAN01/UB1338	82
3.13.8 CMI-COM01/UB1303	84
3.13.9 CMI-DIO01/UB1318	86
3.14 Installing CFM Module	88
3.14.1 CFM-PoE01.....	88
3.14.2 CFM-IGN01.....	91
3.15 Installing Top Cover	92
3.16 Installing Maintenance Area Panel.....	93
3.17 Installing Wall Mount Kit	94
3.18 Installing Side Mount Kit.....	95
3.19 Installing VESA Mount Accessories.....	96
3.20 Installing DIN-Rail Mount Kit.....	97
3.21 Installing External FAN.....	98
Chapter 4 BIOS Setup.....	100
4.1 BIOS Introduction.....	101
4.2 Main Setup.....	102
4.3 Advanced Setup	103
4.3.1 CPU Configuration.....	103

4.3.2 Power & Performance	105
4.3.3 SATA Configuration	105
4.3.4 PCH-FW Configuration	106
4.3.5 Trusted Computing Settings.....	107
4.3.6 ACPI Settings	108
4.3.7 F81966 Super IO Configuration.....	108
4.3.8 Hardware Monitor	110
4.3.9 S5 RTC Wake Settings.....	111
4.3.10 Serial Port Console Redirection.....	112
4.3.11 USB Configuration	112
4.3.12 Network Stack Configuration	113
4.3.13 CSM Configuration	113
4.3.14 NVMe Configuration	114
4.4 Security Setup	114
4.5 Boot Setup	116
4.6 Save & Exit	117
4.8 MEBx	118
Chapter 5 Product Application	121
5.1 Where to download drivers?	122
5.2 Where to find the technical documents?	122

Preface

Revision

Revision	Description	Date
1.00	New Release	2024/11/29
1.01	Antenna Cutout Universal Bracket (Model No. UB1332) Installation Added	2024/11/29
1.02	Antenna Cutout Universal Bracket (Model No. UB0932) Installation Added	2025/03/18
1.03	Intel 14th CPU support Added	2025/06/12
1.04	EN45545-2 Certification Obtained	2025/08/26
1.05	Added CMI-2P5GLAN01, CMI-10GXM12LAN01	2025/12/09
1.06	Correction Made	2025/12/17
1.07	Added CMI-CAN01	2026/04/16

Copyright Notice

© 2024 by Cincoze Co., Ltd. All rights are reserved. No parts of this manual may be copied, modified, or reproduced in any form or by any means for commercial use without the prior written permission of Cincoze Co., Ltd. All information and specifications provided in this manual are for reference only and remain subject to change without prior notice.

Acknowledgement

Cincoze is a registered trademark of Cincoze Co., Ltd. All registered trademarks and product names mentioned herein are used for identification purposes only and may be trademarks and/or registered trademarks of their respective owners.

Disclaimer

This manual is intended to be used as a practical and informative guide only and is subject to change without notice. It does not represent a commitment on the part of Cincoze. This product might include unintentional technical or typographical errors. Changes are periodically made to the information herein to correct such errors, and these changes are incorporated into new editions of the publication.

Declaration of Conformity



FCC

This equipment has been tested and found to comply with the limits for a Class A digital device, pursuant to Part 15 of the FCC Rules. These limits are designed to provide reasonable protection against harmful interference when the equipment is

operated in a commercial environment. This equipment generates, uses, and can radiate radio frequency energy and, if not installed and used in accordance with the instruction manual, may cause harmful interference to radio communications. Operation of this equipment in a residential area is likely to cause harmful interference in which case the user will be required to correct the interference at his own expense.



CE

The product(s) described in this manual complies with all application European Union (CE) directives if it has a CE marking. For computer systems to remain CE compliant, only CE-compliant parts may be used. Maintaining CE compliance also requires proper cable and cabling techniques.



UL

A product that carries the "UL Listed" approval mark means that the product has been tested by UL to nationally recognized Safety Standards and has been found to be free from reasonably foreseeable risk of fire, electric shock and related hazards



E-Mark

The "E" mark is based on ECE regulations issued by the Economic Commission for Europe. It is an organizational part of the UN and the members are EU countries and many others. Therefore, the acceptance of approved components is much broader, especially in the eastern part of Europe. It is necessary to confirm whether a particular country has accepted (signed) the application of an ECE-regulation; as the application it is not mandatory for the countries.

Product Warranty Statement

Warranty

Cincoze products are warranted by Cincoze Co., Ltd. to be free from defect in materials and workmanship for 2 years from the date of purchase by the original purchaser. During the warranty period, we shall, at our option, either repair or replace any product that proves to be defective under normal operation. Defects, malfunctions, or failures of the warranted product caused by damage resulting from natural disasters (such as by lightning, flood, earthquake, etc.), environmental and atmospheric disturbances, other external forces such as power line disturbances, plugging the board in under power, or incorrect cabling, and damage caused by misuse, abuse, and unauthorized alteration or repair, and the product in question is either software, or an expendable item (such as a fuse, battery, etc.), are not warranted.

RMA

Before sending your product in, you will need to fill in Cincoze RMA Request Form and obtain an

RMA number from us. Our staff is available at any time to provide you with the most friendly and immediate service.

■ RMA Instruction

- Customers must fill in Cincoze Return Merchandise Authorization (RMA) Request Form and obtain an RMA number prior to returning a defective product to Cincoze for service.
- Customers must collect all the information about the problems encountered and note anything abnormal and describe the problems on the “Cincoze Service Form” for the RMA number apply process.
- Charges may be incurred for certain repairs. Cincoze will charge for repairs to products whose warranty period has expired. Cincoze will also charge for repairs to products if the damage resulted from acts of God, environmental or atmospheric disturbances, or other external forces through misuse, abuse, or unauthorized alteration or repair. If charges will be incurred for a repair, Cincoze lists all charges, and will wait for customer’s approval before performing the repair.
- Customers agree to ensure the product or assume the risk of loss or damage during transit, to prepay shipping charges, and to use the original shipping container or equivalent.
- Customers can be sent back the faulty products with or without accessories (manuals, cable, etc.) and any components from the system. If the components were suspected as part of the problems, please note clearly which components are included. Otherwise, Cincoze is not responsible for the devices/parts.
- Repaired items will be shipped along with a "Repair Report" detailing the findings and actions taken.

Limitation of Liability

Cincoze’ liability arising out of the manufacture, sale, or supplying of the product and its use, whether based on warranty, contract, negligence, product liability, or otherwise, shall not exceed the original selling price of the product. The remedies provided herein are the customer’s sole and exclusive remedies. In no event shall Cincoze be liable for direct, indirect, special or consequential damages whether based on contract of any other legal theory.

Technical Support and Assistance

1. Visit the Cincoze website at www.cincoze.com where you can find the latest information about the product.
2. Contact your distributor or our technical support team or sales representative for technical support if you need additional assistance. Please have following information ready before you call:
 - Product name and serial number

- Description of your peripheral attachments
- Description of your software (operating system, version, application software, etc.)
- A complete description of the problem
- The exact wording of any error messages

Conventions Used in this Manual



WARNING
(AVERTIR)

This indication alerts operators to an operation that, if not strictly observed, may result in severe injury.

(Cette indication avertit les opérateurs d'une opération qui, si elle n'est pas strictement observée, peut entraîner des blessures graves.)



CAUTION
(ATTENTION)

This indication alerts operators to an operation that, if not strictly observed, may result in safety hazards to personnel or damage to equipment.

(Cette indication avertit les opérateurs d'une opération qui, si elle n'est pas strictement observée, peut entraîner des risques pour la sécurité du personnel ou des dommages à l'équipement.)



NOTE
(NOTE)

This indication provides additional information to complete a task easily.

(Cette indication fournit des informations supplémentaires pour effectuer facilement une tâche.)

Safety Precautions

Before installing and using this device, please note the following precautions.

1. Read these safety instructions carefully.
2. Keep this User's Manual for future reference.
3. Disconnect this equipment from any AC outlet before cleaning.
4. For plug-in equipment, the power outlet socket must be located near the equipment and must be easily accessible.
5. Keep this equipment away from humidity.
6. Put this equipment on a reliable surface during installation. Dropping it or letting it fall may cause damage.
7. Make sure the voltage of the power source is correct before connecting the equipment to the power outlet.
8. Use a power cord that has been approved for using with the product and that it matches the voltage and current marked on the product's electrical range label. The voltage and current rating of the cord must be greater than the voltage and current rating marked on the product.
9. Position the power cord so that people cannot step on it. Do not place anything over the power cord.

10. All cautions and warnings on the equipment should be noted.
11. If the equipment is not used for a long time, disconnect it from the power source to avoid damage from transient overvoltage.
12. Never pour any liquid into an opening. This may cause fire or electrical shock.
13. Never open the equipment. For safety reasons, the equipment should be opened only by qualified service personnel.

If one of the following situations arises, get the equipment checked by service personnel:

- The power cord or plug is damaged.
 - Liquid has penetrated into the equipment.
 - The equipment has been exposed to moisture.
 - The equipment does not work well, or you cannot get it to work according to the user's manual.
 - The equipment has been dropped and damaged.
 - The equipment has obvious signs of breakage.
14. CAUTION: Danger of explosion if battery is incorrectly replaced. Replace only with the same or equivalent type recommended by the manufacturer.
 15. Equipment intended only for use in a RESTRICTED ACCESS AREA.
 16. Output of the external power source shall comply with ES1, PS3 requirements, output rating between 9-48 VDC, minimum 13-2.2A, with minimum rated maximum ambient temperature 70°C, and has to be evaluated according to UL/IEC/EN 60950-1 and/or UL/IEC/EN 62368-1. Please contact Cincoze for more information.
 17. Ensure to connect the power cord of the power adapter to a socket-outlet with an earth connection.
 18. Dispose of used batteries promptly. Keep away from children. Do not disassemble and do not dispose of in fire.

Package Contents

Before installation, please ensure all the items listed in the following table are included in the package.

Item	Description	Q'ty
1	GM-1100 GPU Computer	1
2	CPU Heat Sink Pack	1
3	Screws Pack	1
4	Power Terminal Block Connector	2
5	Remote Function Terminal Block Connector	1
6	External Fan Terminal Block Connector	2
7	Wall Mount Kit	1
8	M.2 Key B Type 3052 to Type 3042 Adapter Bracket	1

Note: Notify your sales representative if any of the above items are missing or damaged.

Ordering Information

Model No.	Product Description
GM-1100	14/13/12th Gen Intel® Core™ Series Embedded GPU Computer, Supports 1x MXM 3.1 GPU Expansion Socket



Chapter 1

Product Introductions

1.1 Overview

The GM-1100 is a compact and rugged embedded MXM GPU computer for high-performance computing needs. It combines powerful computing and graphics processing capabilities with highly flexible expansion, making it ideal for edge AI applications with limited installation space.

Key Features

- Intel® 14/13/12th Gen Core™ i9/i7/i5/i3 Processors (max 65 W TDP)
- Supports 1x MXM 3.1 Type A/B form factor GPU module expansion
- 1x 2.5GbE LAN, 1x 20Gbps USB3.2 Gen2 x2, Type C Connector
- 1x M.2 Key M Type 2280 Socket For Storage/Add-on Card Expansion
- 1x M.2 Key E Type 2230 Socket For Wireless/Bluetooth/Storage/Intel CNVi Module Expansion
- 1x M.2 Key B Type 3042/3052 Socket For 5G/GNSS/Storage/Add-on Card Expansion
- 2x M.2 Key B Type 2242 Socket For GNSS/Storage/Add-on Card Expansion
- Optional CMI & CFM Modules for I/O Expansion & Power Ignition Sensing Function
- Wide operating temperature -40°C to 70°C (-40°F to 158°F)

Certification



MIL-STD-810H



EN 50121-3-2



EN 62368-1



EN 45545



3X Performance boost

Equipped with a 14th generation Intel® Core (Raptor Lake-S Refresh) processor, the GM-1100 is capable of three times the computing performance of its predecessor. For highly complex or specialized tasks the hybrid or P-core monolithic architecture can be chosen for the best performance based on specific needs.

14th Intel® Raptor Lake-S Refresh



MXM GPU module

Type A and B MXM GPU modules allow comprehensive options to suit lightweight AI or high-performance AI inference applications. The special modular design also means painless upgrades to higher-end MXM modules to bolster performance in the future.

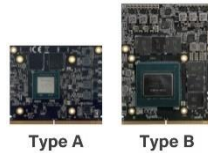

High-speed connections and data storage

Native 2.5GbE LAN and 20Gbps USB 3.2 Gen2x2 Type-C high-speed connections effectively improve the efficiency of image and file transfer. Storage options include two 2.5" HDD/SSD bays and options for high-speed NVMe SSD storage.



Ideal for mobility applications

Compact size (260 x 200 x 85 mm), multiple M.2 expansion slots for 5G or Wi-Fi communication modules, and compliance with rail transit certification (EN50121-3-2) and vehicle certification (E-mark) make the GM-1100 ideal for mobility applications.

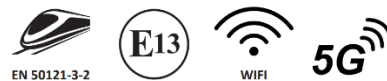

Superior cooling performance

The innovative thermal design improves system cooling by providing independent heat dissipation channels for the CPU and GPU to the upper cover and sides of the extruded aluminum case. Combined with an external fan, it provides a solid foundation for stable and reliable operation.



Rugged safety

The harsh challenges of the Edge AI environment are overcome with industrial grade wide temperature (-40 to 70°C/ -40 to 158°F) and wide voltage (9 to 48 VDC) support, and passing the US military shock standard (MIL-STD-810H) to ensure product stability and safety.



1.2 Hardware Specification

Model Name	GM-1100
System	
Processor	<ul style="list-style-type: none"> • 14th Generation Intel® Raptor Lake-S Refresh Series CPU: <ul style="list-style-type: none"> - Intel® Core™ i9-14900 24 Cores Up to 5.8 GHz, TDP 65W - Intel® Core™ i7-14700 20 Cores Up to 5.4 GHz, TDP 65W - Intel® Core™ i5-14500 14 Cores Up to 5.0 GHz, TDP 65W - Intel® Core™ i5-14400 10 Cores Up to 4.7 GHz, TDP 65W - Intel® Core™ i3-14100 4 Cores Up to 4.7 GHz, TDP 60W - Intel® Core™ i9-14901E 8 Cores Up to 5.6 GHz, TDP 65W - Intel® Core™ i7-14701E 8 Cores Up to 5.4 GHz, TDP 65W - Intel® Core™ i5-14501E 6 Cores Up to 5.2 GHz, TDP 65W - Intel® Core™ i5-14401E 6 Cores Up to 4.7 GHz, TDP 65W - Intel® Core™ i9-14900T 24 Cores Up to 5.5 GHz, TDP 35W - Intel® Core™ i7-14700T 20 Cores Up to 5.2 GHz, TDP 35W - Intel® Core™ i5-14500T 14 Cores Up to 4.8 GHz, TDP 35W - Intel® Core™ i5-14400T 10 Cores Up to 4.5 GHz, TDP 35W - Intel® Core™ i3-14100T 4 Cores Up to 4.4 GHz, TDP 35W - Intel® Core™ i9-14901TE 8 Cores Up to 5.5 GHz, TDP 45W - Intel® Core™ i7-14701TE 8 Cores Up to 5.2 GHz, TDP 45W - Intel® Core™ i5-14501TE 6 Cores Up to 5.1 GHz, TDP 45W - Intel® Core™ i5-14401TE 6 Cores Up to 4.5 GHz, TDP 45W - Intel® Processor 300 2 Cores Up to 3.9 GHz, TDP 46W - Intel® Processor 300T 2 Cores Up to 3.4 GHz, TDP 35W • 13th Generation Intel® Raptor Lake-S Series CPU: <ul style="list-style-type: none"> - Intel® Core™ i9-13900E 24 Cores Up to 5.2 GHz, TDP 65W - Intel® Core™ i7-13700E 16 Cores Up to 5.1 GHz, TDP 65W - Intel® Core™ i5-13500E 14 Cores Up to 4.6 GHz, TDP 65W - Intel® Core™ i5-13400E 10 Cores Up to 4.6 GHz, TDP 65W - Intel® Core™ i3-13100E 4 Cores Up to 4.4 GHz, TDP 65W - Intel® Core™ i9-13900TE 24 Cores Up to 5.0 GHz, TDP 35W - Intel® Core™ i7-13700TE 16 Cores Up to 4.8 GHz, TDP 35W - Intel® Core™ i5-13500TE 14 Cores Up to 4.5 GHz, TDP 35W - Intel® Core™ i3-13100TE 4 Cores Up to 4.1 GHz, TDP 35W • 12th Generation Intel® Alder Lake-S Series CPU: <ul style="list-style-type: none"> - Intel® Core™ i9-12900E 16 Cores Up to 5.0 GHz, TDP 65W - Intel® Core™ i7-12700E 12 Cores Up to 4.8 GHz, TDP 65W - Intel® Core™ i5-12500E 6 Cores Up to 4.5 GHz, TDP 65W

	<ul style="list-style-type: none"> - Intel® Core™ i3-12100E 4 Cores Up to 4.2 GHz, TDP 60W - Intel® Core™ i9-12900TE 16 Cores Up to 4.8 GHz, TDP 35W - Intel® Core™ i7-12700TE 12 Cores Up to 4.7 GHz, TDP 35W - Intel® Core™ i5-12500TE 6 Cores Up to 4.3 GHz, TDP 35W - Intel® Core™ i3-12100TE 4 Cores Up to 4.0 GHz, TDP 35W - Intel® Pentium® G7400E 2 Cores Up to 3.6 GHz, TDP 46W - Intel® Pentium® G7400TE 2 Cores Up to 3.0 GHz, TDP 35W - Intel® Celeron® G6900E 2 Cores Up to 3.0 GHz, TDP 46W - Intel® Celeron® G6900TE 2 Cores Up to 2.4 GHz, TDP 35W
Chipset	<ul style="list-style-type: none"> • Intel R680E Chipset
Memory	<ul style="list-style-type: none"> • 2x DDR5 SO-DIMM sockets, support Un-buffered and ECC Type memory, up to 96GB. - Core™ i9/i7: Support 5600/4800 MHz with Single Rank memory and 5200/4800 MHz with Dual Rank memory. - Core™ i5/i3/Pentium®/Celeron®/Intel® Processor: Support 4800 MHz.
BIOS	<ul style="list-style-type: none"> • AMI BIOS
Graphics	
Graphics Engine	<ul style="list-style-type: none"> • Integrated Intel® UHD Graphics 770: Core™ i9/i7/i5 • Integrated Intel® UHD Graphics 730: Core™ i3 • Integrated Intel® UHD Graphics 710: Pentium®/Celeron®
Maximum Display Output	<ul style="list-style-type: none"> • Supports Triple Independent Display
DP	<ul style="list-style-type: none"> • 1x DisplayPort Connector (4096 x 2304 @60Hz) *Verified maximum resolution: 3840 x 2160@60Hz
HDMI	<ul style="list-style-type: none"> • 1x HDMI Connector (4096 x 2160@30Hz) *Verified maximum resolution: 3840 x 2160@30Hz
VGA	<ul style="list-style-type: none"> • 1x VGA Connector (1920 x 1200 @60Hz)
Audio	
Audio Codec	<ul style="list-style-type: none"> • Realtek® ALC888, High Definition Audio
Line-out	<ul style="list-style-type: none"> • 1x Line-out, Phone Jack 3.5mm
Mic-in	<ul style="list-style-type: none"> • 1x Mic-in, Phone Jack 3.5mm
I/O	
LAN	<ul style="list-style-type: none"> • 1x 2.5GbE LAN, RJ45 - Intel® I225 • 1x 1GbE LAN, RJ45 - Intel® I219
COM	<ul style="list-style-type: none"> • 4x RS-232/422/485 with Auto Flow Control (Supports 5V/12V), DB9
USB	<ul style="list-style-type: none"> • 1x 20Gbps USB3.2 Gen 2x2, Type C • 3x 10Gbps USB 3.2 Gen 2x1, Type A • 4x 5Gbps USB 3.2 Gen 1x1, Type A
Storage/ Expansion	

2.5" SSD/HDD	<ul style="list-style-type: none"> • 2x 2.5" Front Accessible SATA HDD/SSD Bay Supporting Hot Swap Function (SATA 3.0) (Up to 15mm in Height)
M.2 M Key Socket	<ul style="list-style-type: none"> • 1x M.2 Key M Type 2280 Socket (PCIe Gen 4x4 / SATA), Support Storage/ Add-on Card Expansion
M.2 Key E Socket	<ul style="list-style-type: none"> • 1x M.2 Key E Type 2230 Socket (PCIe Gen 3x2 / USB2.0), Support Wireless/Bluetooth/Storage/Intel CNVi Module Expansion
M.2 Key B Socket	<ul style="list-style-type: none"> • 1x M.2 Key B Type 3042/3052 Socket (PCIe Gen 3x2 / USB3.2 Gen2x1 / SATA), Support 5G/GNSS/Storage/Add-on Card Expansion • 2x M.2 Key B Type 2242 Socket (PCIe Gen 4x2 / USB2.0 / SATA), Support GNSS/Storage/Add-on Card Expansion
MXM Socket	<ul style="list-style-type: none"> • 1x MXM Carrier Board Socket for MXM GPU Module Expansion
SIM Socket	<ul style="list-style-type: none"> • 2x SIM Socket
CMI (Combined Multiple I/O) Interface	<ul style="list-style-type: none"> • 1x High Speed CMI Interface for optional CMI Module Expansion • 1x Low Speed CMI Interface for optional CMI Module Expansion
CFM (Control Function Module) Interface	<ul style="list-style-type: none"> • 1x CFM IGN Interface for optional CFM-IGN Module Expansion
Other Function	
RAID	<ul style="list-style-type: none"> • Support RAID 0/1/5/10
External FAN Connector	<ul style="list-style-type: none"> • 2x External FAN Connector, 4-pin Terminal Block (Support Smart Fan by BIOS)
Power Ignition Sensing	<ul style="list-style-type: none"> • Support Power Ignition Sensing Function with Delay Time Management and Selectable 12V/24V (With Optional CFM Module)
Clear CMOS Switch	<ul style="list-style-type: none"> • 1x Clear CMOS Switch
Reset Button	<ul style="list-style-type: none"> • 1x Reset Button
Instant Reboot	<ul style="list-style-type: none"> • Support 0.2sec Instant Reboot Technology
Watchdog Timer	<ul style="list-style-type: none"> • Software Programmable Supports 256 Levels System Reset
Antenna Holes	<ul style="list-style-type: none"> • 2x Antenna Holes
Status LED Indicator	<ul style="list-style-type: none"> • HDD LED 、 GPIO LED 、 IGN LED 、 GPU LED 、 Ethernet LED
Power	
Power Button	<ul style="list-style-type: none"> • 1x ATX Power On/Off Button
Power Mode Switch	<ul style="list-style-type: none"> • 1x AT/ATX Mode Switch
Power Input	<ul style="list-style-type: none"> • 9-48 VDC, Single Power Source Connector Type: 2x 3-pin Terminal Block, Each Terminal Block Current Limitation is 15A • Power input voltage from 9V to 23V must use dual power connectors, power input voltage from 24V to 48V can use single power connector
Remote Power On/Off	<ul style="list-style-type: none"> • 1x Remote Power On/Off, 2-pin Terminal Block
Max. Power Consumption	<ul style="list-style-type: none"> • 35W CPU: 187.51W • 65W CPU: 258.96W - Test conducted with CPU, 1x RAM, and 1x storage - 100% load during burn-in testing.

Inrush Current (Peak)	<ul style="list-style-type: none"> • 35W CPU: 5.467 A@24V • 65W CPU: 5.725 A@24V
Physical	
Dimension (W x D x H)	• 260 x 200 x 85 mm
Weight Information	• 4.73 kg
Mechanical Construction	• Extruded Aluminum with Heavy Duty Metal
Mounting	• Wall / Side / DIN-RAIL / VESA Mount
Physical Design	<ul style="list-style-type: none"> • Fanless Design • Cableless Design • Jumper-less Design • Unibody Design
Reliability & Protection	
Reverse Power Input Protection	• Yes
Over Voltage Protection	<ul style="list-style-type: none"> • Protection Range: 51-58V • Protection Type: shut down operating voltage, re-power on at the present level to recover
Over Current Protection	• 30A
CMOS Battery Backup	• SuperCap Integrated for CMOS Battery Maintenance-free Operation
MTBF	<ul style="list-style-type: none"> • 313,541 Hours - Database: Telcordia SR-332 Issue3, Method 1, Case 3
Operating System	
Windows	• Windows®11, Windows®10
Linux	• Ubuntu Desktop 22.04 LTS
Environment	
Operating Temperature	<ul style="list-style-type: none"> • 35W TDP Processor: -40°C to 70°C (-40°F to 158°F) • 45W TDP Processor with external FAN: -40°C to 60°C (-40°F to 140°F) • 65W TDP Processor with external FAN: -40°C to 60°C (-40°F to 140°F) * PassMark BurnInTest: 100% CPU, 2D/3D Graphics (without thermal throttling) * With extended temperature peripherals; Ambient with air flow * According to IEC60068-2-1, IEC60068-2-2, IEC60068-2-14
Storage Temperature	• -40°C to 70°C
Relative Humidity	• 95%RH @ 70°C (Non-condensing)
Shock	• MIL-STD-810H
Vibration	• MIL-STD-810H
EMC	<ul style="list-style-type: none"> • CE, UKCA, FCC, ICES-003 Class A • EN 50155 (EN 50121-3-2 Only) • E-mark
EMI	<ul style="list-style-type: none"> • CISPR 32 Conducted & Radiated: Class A • EN/BS EN 50121-3-2 Conducted & Radiated: Class A • EN/BS EN IEC 61000-3-2 Harmonic current emissions: Class A

	<ul style="list-style-type: none"> • EN/BS EN 61000-3-3 Voltage fluctuations & flicker • FCC 47 CFR Part 15B, ICES-003 Conducted & Radiated: Class A
EMS	<ul style="list-style-type: none"> • EN/IEC 61000-4-2 ESD: Contact: 6 kV; Air: 8 kV • EN/IEC 61000-4-3 RS: 80 MHz to 1000 MHz: 20 V/m • EN/IEC 61000-4-4 EFT: AC Power: 2 kV; Signal: 2 kV • EN/IEC 61000-4-5 Surges: AC Power: 2 kV • EN/IEC 61000-4-6 CS: 10V (**Compliant with the standard when utilizing shielded cable.) • EN/IEC 61000-4-8 PFMF: 50 Hz, 1A/m • EN/IEC 61000-4-11 Voltage Dips & Voltage Interruptions: 0.5 cycles at 50 Hz
Fire Protection	<ul style="list-style-type: none"> • EN45545-2
Safety	<ul style="list-style-type: none"> • UL, cUL, CB, IEC, EN 62368-1

** Product Specifications and features are for reference only and are subject to change without prior notice. For more information, please refer to the latest product datasheet from Cincoze's website.*

1.3 External Layout

1.3.1 Front

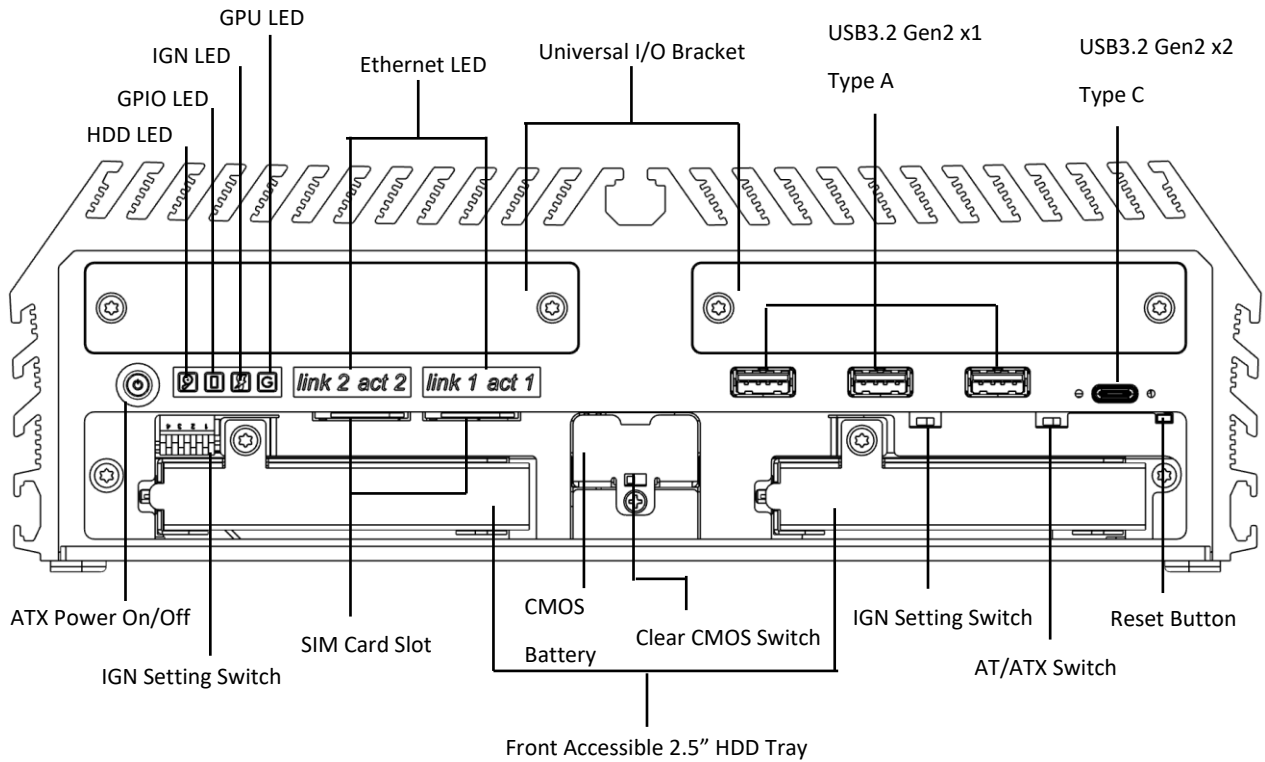

1.3.2 Rear

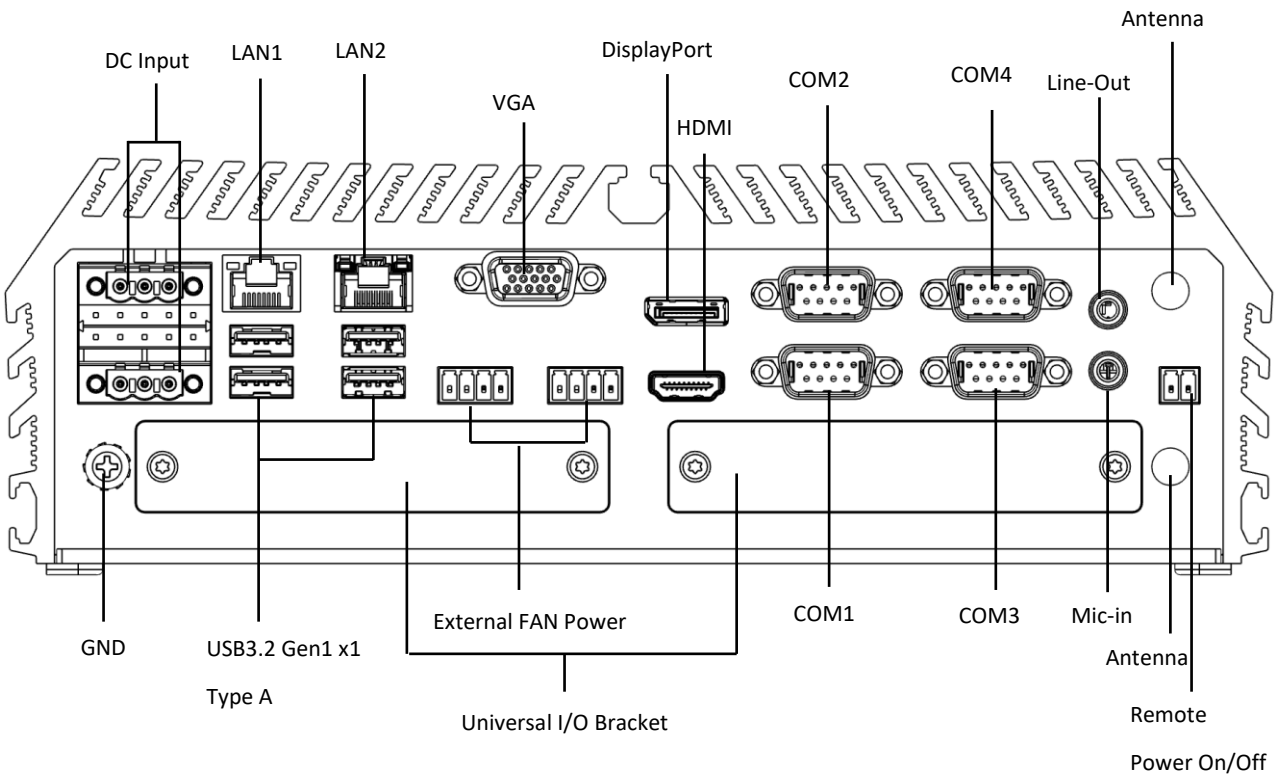

1.4 Dimensions

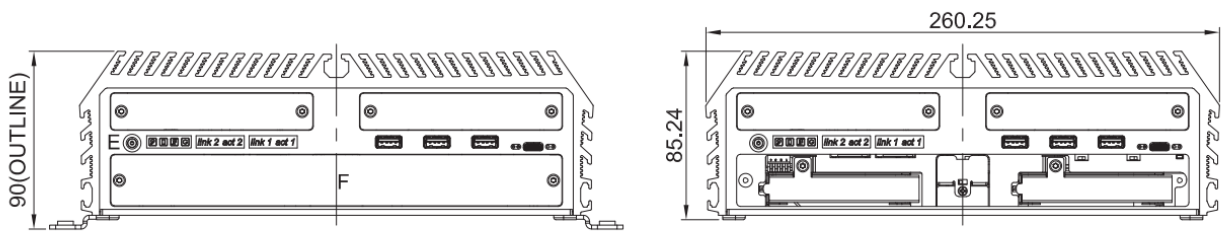
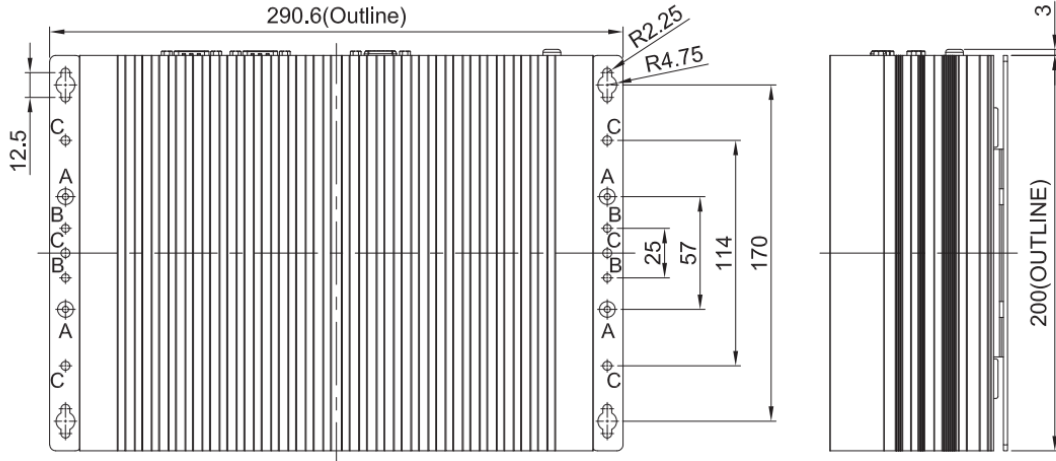

Unit: mm



Chapter 2

Switches & Connectors

2.1 Location of Switches and Connectors

2.1.1 Top View

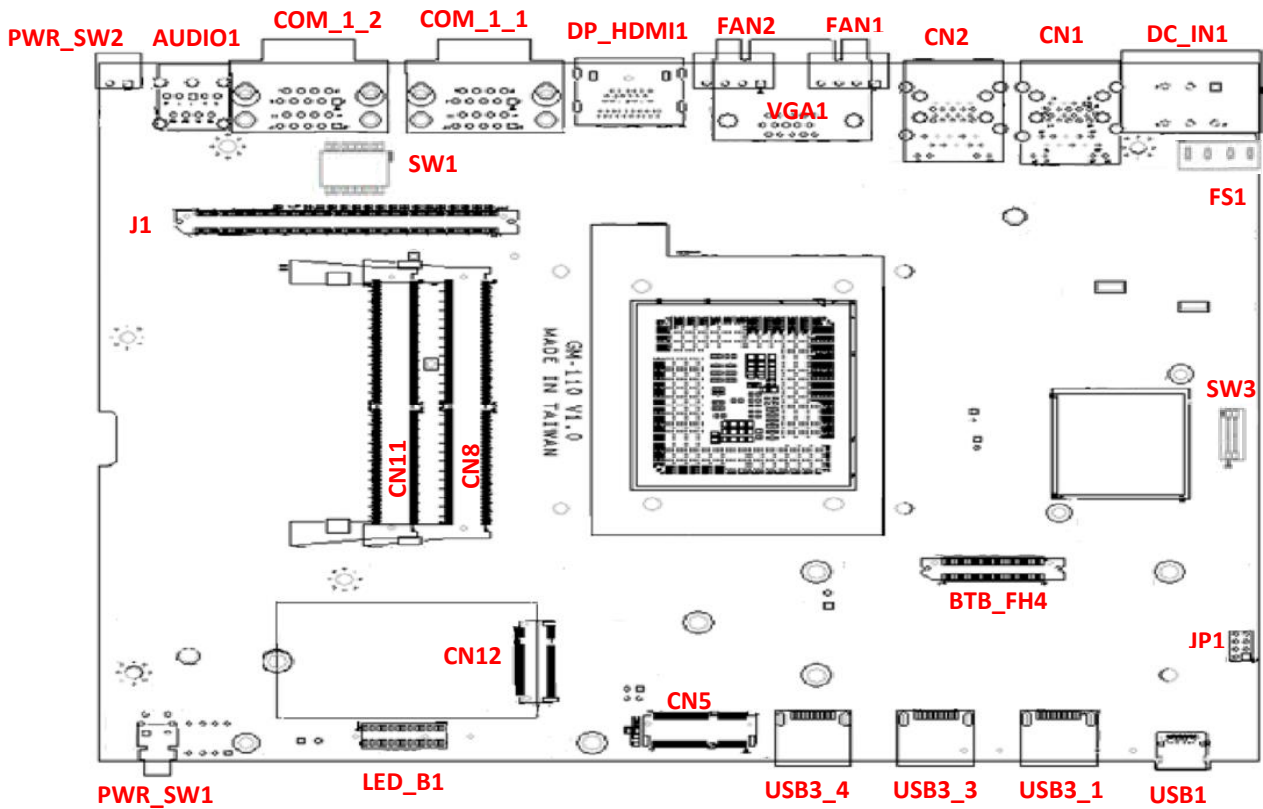

2.1.2 Bottom View

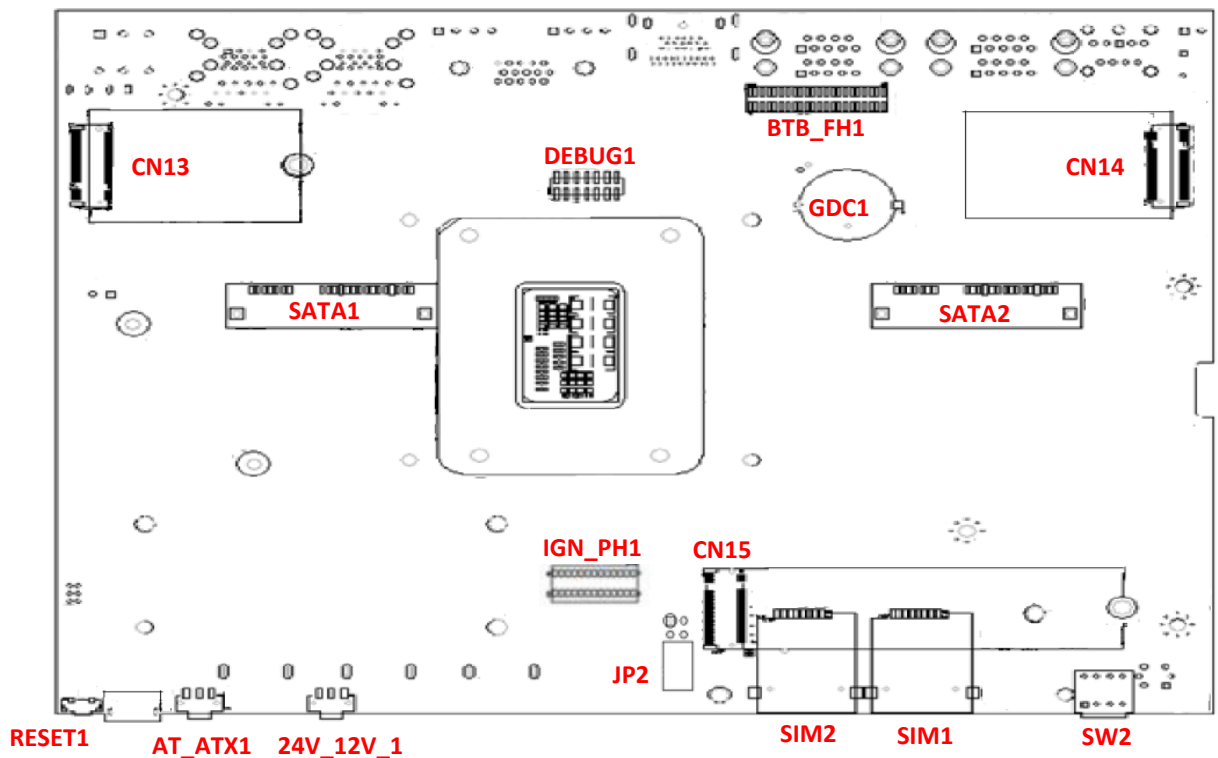

2.2 Switches and Connectors Definition

Location	Definition
AT_ATX1	AT / ATX Power Mode Switch
AUDIO1	Headphone Line out and MIC Phone in Connector
BTB_FH1	Board to Board Connector for DIO or COM Port 5/6 Module
BTB_FH4	Board to Board Connector for 1GbE /2.5GbE/ 10GbE LAN Module
CN5	M.2 Key E Type 2230 Connector (Support PCIE/CNVi/USB2)
CN8, CN11	DDR5 SO-DIMM Sockets
CN1	LAN1 (1GbE) and USB3.2 GEN1x1 Ports (2Ports)
CN2	LAN2 (2.5GbE) and USB3.2 GEN1x1 Ports (2Ports)
CN12	M.2 Key B Type 3052 Connector (Support PCIE/SATA/USB3)
CN13, CN14	M.2 Key B Type 2242 Connector (Support PCIE/SATA)
CN15	M.2 Key M Type 2280 Connector (Support PCIE/SATA)
COM_1_1, COM_1_2	COM1~COM4 Connector (Support RS232/RS422/RS485)
DC_IN1	3 Pins x2 DC 9-48V Power Input with Power Ignition Connector
DEBUG1	Debug Port Header
DP_HDMI1	Display Port and HDMI Connector
FAN1	CPU Smart Fan Connector
FAN2	GPU (MXM) Smart FAN Connector
FS_1	DC Input Fuse 30A/58V
GDC1	Super Cap for CMOS Backup
IGN_PH1	IGN Module Board to Board Connector
J1	PEG to MXM Carrier Board Connector
JP2	RTC Battery Board Connector
JP1	SPI BIOS Programmer Connector
LED_B1	LED Board Connector for HDD/ GPIO/ IGN/ GPU LED
PWR_SW1	System Power Button with Power on LED
PWR_SW2	Remote Power On/Off Switch Connector
RESET1	System Reset Button
SATA1, SATA2	2.5" SATA HDD/SSD Connector
SIM1, SIM2	SIM Card Socket 1 and 2
SW1	COM1/COM2/COM3/COM4 Power Select Switch
SW2	IGN Module Function and Boot Delay Time Setting Switch
SW3	Super CAP Control Switch
USB1	USB3.2 GEN2x2 TYPE C Connector
USB3_1, USB3_3, USB3_4	USB3.2 GEN2x1 TYPE A Connector
VGA1	VGA DB 15 Connector
24V_12V_1	IGN Module Voltage Mode Setting Switch

2.3 Switches Definition

AT_ATX1: AT / ATX Power Mode Switch

Switch	Definition
Left	AT Power Mode
Right	ATX Power Mode (Default)



CN1: LAN1 (1GbE) and USB3.2 GEN1x1 Ports (2Ports)

LAN LED Status Definition

Link Speed LED Status	Definition
Steady Green	1 Gbps Network Link
Steady Orange	100 Mbps Network Link
Off	10 Mbps Network Link
Link Act LED Status	Definition
Blinking Yellow	Link and Data Activity
Steady Yellow	Link but No Activity
Off	No Link

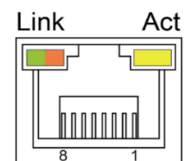

CN2: LAN2 (2.5GbE) and USB3.2 GEN1x1 Ports (2Ports)

LAN LED Status Definition

Link Speed LED Status	Definition
Steady Green	2.5 Gbps Network Link
Steady Orange	1 Gbps Network Link
Off	100 Mbps/ 10 Mbps Network Link
Link Act LED Status	Definition
Blinking Yellow	Link and Data Activity
Steady Yellow	Link but No Activity
Off	No Link

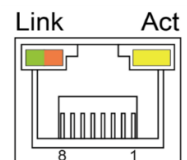

JP2: RTC Battery Board Connector

Clear CMOS Setting Switch on the Battery Board

Switch	Definition
Left	Normal (Default)
Right	Clear CMOS



WARNING
(AVERTIR)

After performing Clear CMOS, the system will take several minutes to start. This is normal. During this process, the system will POST three times, and the system's Power LED will alternate between green and blue lights.

(Après avoir effectué Clear CMOS, le système prendra plusieurs minutes pour démarrer. Cela est normal. Pendant ce processus, le système effectuera trois fois le POST, et la LED d'alimentation du système alternera entre les lumières verte et bleue.)

LED_B1: LED Board Connector for HDD/ GPIO/ IGN/ GPU/ LAN LED



HDD GPIO IGN GPU LAN2 Link LAN2 Act LAN1 Link LAN1 Act

LED Type	Status	LED Color		
HDD LED	No activity	No light		
	SATA/M.2 SSD data activity	Blinking Yellow		
GPIO LED	No activity	No light		
	GPIO activity	Green		
IGN LED	IGN module not installed		No light	
	IGN module installed	IGN disabled		Green
		IGN enabled	ACC OFF	Blue
			ACC ON	Green
GPU LED	GPU (MXM Module) not installed		No light	
	GPU (MXM Module) Installed		Green	
LAN1 Link LED	1Gbps Network Link		Green	
	100Mbps Network Link		Orange	
	10Mbps Network Link		No light	
LAN1 Act LED	Link and data Activity		Blinking Yellow	
	Link but no Activity		Steady Yellow	
	No Link		No light	
LAN2 Link LED	2.5Gbps Network Link		Green	
	1Gbps Network Link		Orange	
	100Mbps Network Link		No light	
LAN2 Act LED	Link and data activity		Blinking Yellow	
	Link but no activity		Steady Yellow	
	No Link		No light	

PWR_SW1: System Power Button with Power on LED

Switch	Definition	
Push	Power System	
LED Type	LED Status	Status
Power LED	Blue	Power off (S4/S5)
	Green	Power on (S0)
	Blinking Blue & Green	Stand by (S3)



RESET1: System Reset Button

Switch	Definition
Push	Reset System



SW1: COM1/COM2/COM3/COM4 Power Select Switch

Location	Function		DIP1	DIP2
SW1	COM1	RI	ON (Default)	ON (Default)
		5V	ON	OFF
		12V	OFF	OFF

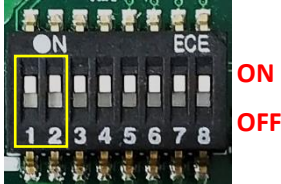

Location	Function		DIP3	DIP4
SW1	COM2	RI	ON (Default)	ON (Default)
		5V	ON	OFF
		12V	OFF	OFF

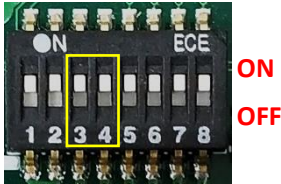

Location	Function		DIP5	DIP6
SW1	COM3	RI	ON (Default)	ON (Default)
		5V	ON	OFF
		12V	OFF	OFF

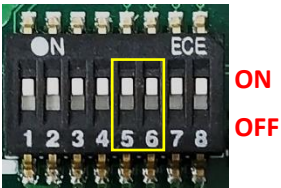

Location	Function		DIP7	DIP8
SW1	COM4	RI	ON (Default)	ON (Default)
		5V	ON	OFF
		12V	OFF	OFF

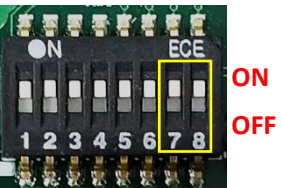

SW3: Super CAP Control Switch

Location	Function	DIP1	DIP2
SW3	Super CAP Enabled	ON (Default)	ON (Default)
	Super CAP Disabled	OFF	



2.4 Definition of Connectors

CN5 : M.2 Key E Type 2230 Connector (Support PCIE/CNVi/USB2)

Pin No.	PIN Name	Pin No.	Pin name
1	GND	2	3.3V
3	USB_D+	4	3.3V
5	USB_D-	6	NC
7	GND	8	PCM_CLK
9	WGR_D1N	10	PCM_SYNC
11	WGR_D1P	12	PCM_IN
13	GND	14	PCM_OUT
15	WGR_D0N	16	NC
17	WGR_D0P	18	GND
19	GND	20	UART_WAKE
21	WGR_CLKN	22	BRI_RSP
23	WGR_CLKP	24	Key
25	Key	26	Key
27	Key	28	Key
29	Key	30	Key
31	Key	32	RGI_DT
33	GND	34	RGI_RSP
35	PETP0	36	BRI_DT
37	PETN0	38	CLINK_RST#
39	GND	40	CLINK_DATA
41	PERP0	42	CLINK_CLK
43	PERN0	44	COEX3
45	GND	46	COEX_TXD
47	REFCLKP0	48	COEX_RXD
49	REFCLKN0	50	SUSCLK
51	GND	52	PERST0#
53	CLKREQ0#	54	W_DISABLE2# (PU to +3.3V)
55	PEWAKE0#	56	W_DISABLE1# (PU to +3.3V)
57	GND	58	I2C_DATA
59	WTD1N/PETP1	60	I2C_CLK
61	WTD1P/PETN1	62	NC
63	GND	64	NC
65	WTD0N/PERP1	66	NC
67	WTD0P/PERN1	68	CLKREQ1#

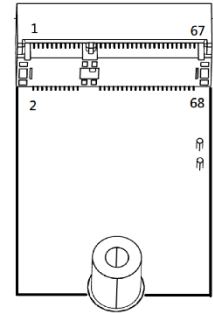

69	GND	70	PEWAKE1#
71	WTCLKN/REFCLKP1	72	3.3V
73	WTCLKP/REFCLKN1	74	3.3V
75	GND		

CN12 : M.2 Key B Type 3052 Connector (Support PCIE/SATA/USB3)

Pin No.	PIN Name	Pin No.	Pin name
1	CFG3	2	+3.3V
3	GND	4	+3.3V
5	GND	6	FULLCARD_PWROFF# (PU to +3.3V)
7	USB2_D+	8	W_DISABLE1# (PU to +3.3V)
9	USB2_D-	10	DAS/DSS#/LED#1
11	GND	12	Key
13	Key	14	Key
15	Key	16	Key
17	Key	18	Key
19	Key	20	NC
21	CFG0	22	NC
23	NC	24	NC
25	NC	26	NC
27	GND	28	NC
29	PERN1/USB3_RX-	30	USIM_RESET
31	PERP1/USB3_RX+	32	USIM_CLK
33	GND	34	USIM_DATA
35	PETN1/USB3_TX-	36	USIM_PWR
37	PETP1/USB3_TX+	38	DEVSLP
39	GND	40	USIM_DET2
41	PERNO/SATA_B+	42	USIM_DATA2
43	PERPO/SATA_B-	44	USIM_CLK2
45	GND	46	USIM_RESET2
47	PETNO/SATA_A-	48	USIM_PWR2
49	PETPO/SATA_A+	50	RESET#
51	GND	52	CLKREQ#
53	REFCLKN	54	WAKE#
55	REFCLKP	56	NC
57	GND	58	NC
59	NC	60	NC
61	NC	62	NC
63	NC	64	NC

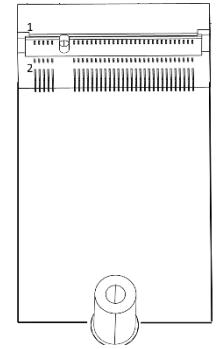

65	NC	66	USIM_DET
67	PERST2# FOR WWAN	68	NC
69	CFG1 (L= SATA, H= PCIE)	70	+3.3V
71	GND	72	+3.3V
73	GND	74	+3.3V
75	CFG2		

CN13, CN14 : M.2 Key B Type 2242 Connector (Support PCIE/SATA)

Pin No.	PIN Name	Pin No.	Pin name
1	NC	2	+3.3V
3	GND	4	+3.3V
5	GND	6	NC
7	USB2_D+	8	NC
9	USB2_D-	10	DAS/DSS#/LED#1
11	GND	12	Key
13	Key	14	Key
15	Key	16	Key
17	Key	18	Key
19	Key	20	NC
21	NC	22	NC
23	NC	24	NC
25	NC	26	NC
27	GND	28	NC
29	PERN1	30	NC
31	PERP1	32	NC
33	GND	34	NC
35	PETN1	36	NC
37	PETP1	38	DEVSLP
39	GND	40	NC
41	PERNO/SATA_B+	42	NC
43	PERPO/SATA_B-	44	NC
45	GND	46	NC
47	PETNO/SATA_A-	48	NC
49	PETPO/SATA_A+	50	RESET#
51	GND	52	CLKREQ#
53	REFCLKN	54	WAKE#
55	REFCLKP	56	NC
57	GND	58	NC
59	NC	60	NC

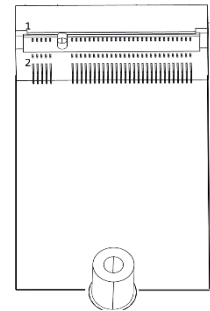

61	NC	62	NC
63	NC	64	NC
65	NC	66	NC
67	NC	68	NC
69	CFG1 (L= SATA, H= PCIE)	70	+3.3V
71	GND	72	+3.3V
73	GND	74	+3.3V
75	NC		

CN15 : M.2 Key M Type 2280 Connector (Support PCIE/SATA)

Pin No.	PIN Name	Pin No.	Pin name
1	CFG3 (PU to +3.3V)	2	+3.3V
3	GND	4	+3.3V
5	PERN3	6	NC
7	PERP3	8	NC
9	GND	10	DAS/DSS*
11	PETN3	12	+3.3V
13	PETP3	14	+3.3V
15	GND	16	+3.3V
17	PERN2	18	+3.3V
19	PERP2	20	NC
21	CFG0 (PU to +3.3V)	22	NC
23	PETN2	24	NC
25	PETP2	26	NC
27	GND	28	NC
29	PERN1	30	NC
31	PERP1	32	NC
33	GND	34	NC
35	PETN1	36	NC
37	PETP1	38	DEVSLP
39	GND	40	SMB_CLK
41	PERNO/SATA_B+	42	SMB_DATA
43	PERPO/SATA_B-	44	ALERT#
45	GND	46	NC
47	PETNO/SATA_A-	48	NC
49	PETPO/SATA_A+	50	PERST#
51	GND	52	CLKREQ#
53	REFCLKN	54	PEWAKE#
55	REFCLKP	56	NC

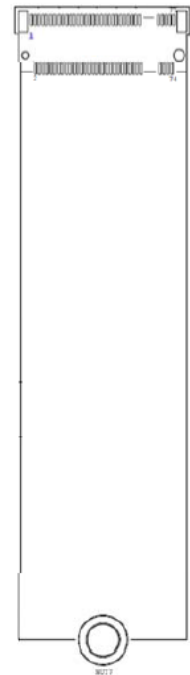

57	GND	58	NC
59	Key	60	Key
61	Key	62	Key
63	Key	64	Key
65	Key	66	Key
67	NC	68	SUSCLK
69	PEDET/CFG1	70	+3.3V
71	GND	72	+3.3V
73	GND	74	+3.3V
75	CFG2 (PU to +3.3V)		

COM_1_1, COM_1_2: COM1 ~ COM4 Connector (Support RS232/RS422/RS485)

Connector Type: 9-pin D-Sub

Pin	RS232 Definition	RS422 / 485 Full Duplex Definition	RS485 Half Duplex Definition
1	DCD	TX-	DATA -
2	RXD	TX+	DATA +
3	TXD	RX+	
4	DTR	RX-	
5	GND		
6	DSR		
7	RTS		
8	CTS		
9	RI		



DC_IN1: 3 Pins x2 DC 9-48V Power Input with Power Ignition Connector

Connector Type: Terminal Block 2x3 6-pin, 5.0mm pitch

Pin	Definition
1	+VCC (9-48)
2	ACC (Ignition)
3	GND
4	+VCC (9-48)
5	NC
6	GND

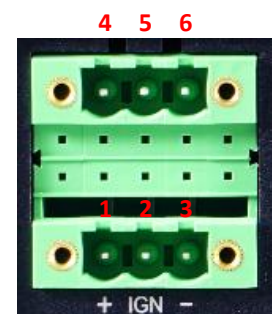

CAUTION
(ATTENTION)

Only Single Power Source can connect to DC_IN1. And please disconnect the power source before mounting the DC power cables or connecting the DC power connector to system. (Seule une source d'alimentation unique peut être connectée à DC_IN1. Veuillez débrancher la source d'alimentation avant d'installer les câbles d'alimentation DC ou de connecter le connecteur d'alimentation DC au système.)

FAN1 : CPU smart FAN connector

FAN2 : GPU (MXM) smart FAN connector

Connector Type: 1x 4-pins Terminal Block , 3.5mm pitch

Pin	Definition
1	GND
2	+12V
3	FAN_IN
4	FAN_PWM

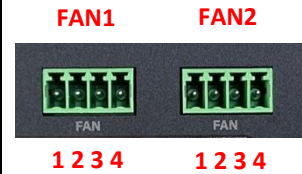

PWR_SW2: Remote Power On/Off Switch Connector

Connector Type: Terminal Block 1X2 2-pin, 3.5mm pitch

Pin	Definition
1	PWR_SW
2	GND



WARNING (AVERTIR) Do not apply power to this connector! This port is used to connect a SWITCH!
 (Ne mettez pas sous tension ce connecteur! Ce port est utilisé pour connecter un SWITCH!)

2.5 Optional Module: Definition of Switches and Connectors

2.5.1 CMI-LAN01

LAN LED Status Definition

Link Speed LED Status	Definition
Steady Green	1 Gbps Network Link
Steady Orange	100 Mbps Network Link
Off	10 Mbps Network Link
Link Act LED Status	Definition
Blinking Yellow	Link and Data Activity
Steady Yellow	Link but No Activity
Off	No Link

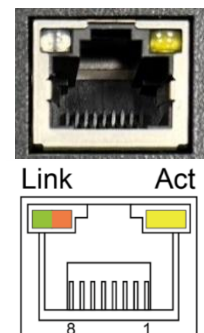

2.5.2 CMI-M12LAN01

CMI-M12LAN01 Module Pin Definitions

Connector Type: M12 A-coded 8pin connector

Pin	Definition	Pin	Definition
1	2_LAN1_0+	2	2_LAN1_0-
3	2_LAN1_1+	4	2_LAN1_2+
5	2_LAN1_2-	6	2_LAN1_1-
7	2_LAN1_3+	8	2_LAN1_3-

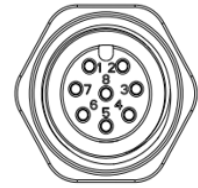

2.5.3 CMI-2P5GLAN01

LAN (I225) LED Status Definition

Link Speed LED Status	Definition
Steady Green	2.5 Gbps Network Link
Steady Orange	1 Gbps Network Link
Off	100 Mbps Network Link
Off	10 Mbps Network Link
Link Act LED Status	Definition
Blinking Yellow	Link and Data Activity
Steady Yellow	Link but No Activity

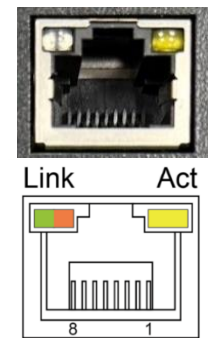

2.5.4 CMI-10GXM12LAN01

LAN (X550) LED Status Definition

Link Speed LED Status	Definition
Steady Green	10 Gbps Network Link
Steady Orange	1 Gbps Network Link
Off	100 Mbps Network Link
Link Act LED Status	Definition
Blinking Yellow	Link and Data Activity
Steady Yellow	Link but No Activity



LAN Port Pin Definitions

Connector Type: M12 X coded 8pin connector

Pin	Definition	Pin	Definition
1	MDX0+	2	MDX0-
3	MDX1+	4	MDX1-
5	MDX3+	6	MDX3-
7	MDX2-	8	MDX2+
9	GND		

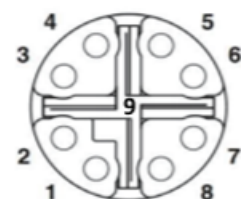

2.5.5 CMI-XM12LAN01

CMI-XM12LAN01 Module Pin Definitions

Connector Type: M12 X-coded 8pin connector

Pin	Definition	Pin	Definition
1	D1+	2	D1-
3	D2+	4	D2-
5	D4+	6	D4-
7	D3-	8	D3+

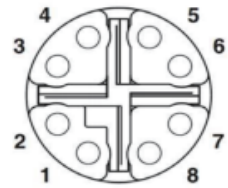

2.5.6 CMI-10GLAN01

LAN LED Status Definition

Link Speed LED Status	Definition
Steady Green	10 Gbps Network Link
Steady Orange	1 Gbps Network Link
Off	100 Mbps Network Link
Link Act LED Status	Definition
Blinking Green	Link and Data Activity
Steady Green	Link but No Activity
Off	No Link

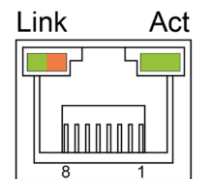

2.5.7 CMI-COM01

COM1 and COM2 (on the module) : COM5 and COM6 Connectors on the system
(Support RS232/RS422/RS485)

Connector Type: 9-pin D-Sub

Pin	RS232 Definition	RS422 / 485 Full Duplex Definition	RS485 Half Duplex Definition
1	DCD	TX-	DATA -
2	RXD	TX+	DATA +
3	TXD	RX+	
4	DTR	RX-	
5	GND		
6	DSR		
7	RTS		
8	CTS		
9	RI		



SW2 (on the module) : COM5 Power Select Switch

Location	Function		DIP1	DIP2
SW2	COM5	RI	ON (Default)	ON (Default)
		5V	ON	OFF
		12V	OFF	OFF

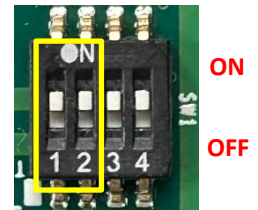

SW2 (on the module) : COM6 Power Select Switch

Location	Function		DIP3	DIP4
SW2	COM6	RI	ON (Default)	ON (Default)
		5V	ON	OFF
		12V	OFF	OFF

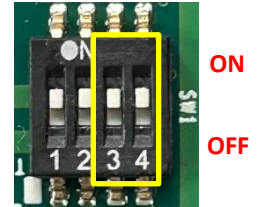

2.5.8 CMI-CAN01

COM1 and COM2 (on the module) : CAN BUS Connector

Connector Type: 9-pin D-Sub

Pin	CAN BUS1 Definition	CAN BUS2 Definition
1	N.C	N.C
2	CAN1L	CAN2L
3	GND	GND
4	N.C	N.C
5	N.C	N.C
6	GND	GND
7	CAN1H	CAN2H
8	N.C	N.C
9	N.C	N.C



SW1: COM1/COM2 120Ω Terminating Resistor Select

Location	Function		DIP1	DIP2
SW1 on CMI-CAN Module	COM1	Enabled	OFF (Default)	OFF (Default)
		Disabled	ON	ON



Location	Function		DIP1	DIP2
SW1 on CMI-CAN Module	COM2	Enabled	OFF (Default)	OFF (Default)
		Disabled	ON	ON



2.5.9 CMI-DIO01

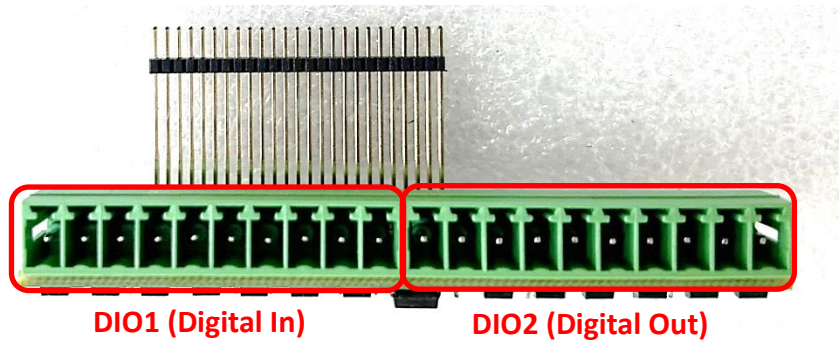

DIO1 (on the module): Digital IN Connector

Connector Type: Terminal Block 1X10 10-pin, 3.5mm pitch

Pin	Definition	Pin	Definition
1	XCOM+ (DC INPUT)	6	DI5
2	DI1	7	DI6
3	DI2	8	DI7
4	DI3	9	DI8
5	DI4	10	XCOM- (GND)



DIO2 (on the module) : Digital OUT Connector

Connector Type: Terminal Block 1X10 10-pin, 3.5mm pitch

Pin	Definition	Pin	Definition
1	XCOM+ (DC INPUT)	6	DO5
2	DO1	7	DO6
3	DO2	8	DO7
4	DO3	9	DO8
5	DO4	10	XCOM- (GND)



2.5.10 CFM-IGN01

SW2 : IGN Module Function and Boot Delay Time Setting Switch

Set shutdown delay timer when ACC is turned off.

This switch functions only when applying CFM-IGN module.

DIP1	DIP 2	DIP 3	DIP 4	Definition
ON (IGN Enabled)	ON	ON	ON	0 second
	ON	ON	OFF	1 minute
	ON	OFF	ON	5 minutes
	ON	OFF	OFF	10 minutes
/	OFF	ON	ON	30 minutes
	OFF	ON	OFF	1 hour
	OFF	OFF	ON	2 hours
	OFF	OFF	OFF	Reserved (0 second)

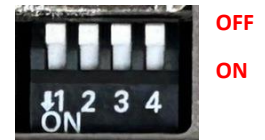

Default setting of Pin1 to Pin4 is OFF / OFF / OFF / OFF.



24V_12V_1 : IGN Module Voltage Mode Setting Switch

12V / 24V Car Battery Switch.

This switch functions only when applying CFM-IGN04 module.

Switch	Definition
Left	12V Car Battery Input
Right	24V Car Battery Input (Default)





Chapter 3

System Setup

3.1 Removing Top Cover



WARNING
(AVERTIR)

In order to prevent electric shock or system damage, must turn off power and disconnect the unit from power source before removing the chassis cover.

(Afin d'éviter tout risque d'électrocution ou d'endommagement du système, vous devez couper l'alimentation et débrancher l'appareil de la source d'alimentation avant de retirer le couvercle du châssis.)

Step 1. Turn over the unit to have the bottom side face up, loosen the 6 screws on the bottom cover and place them aside for later use.



Step 2. Remove the bottom cover from the chassis.



Step 3. Loosen the 4 screws. Pull out 4 latches as marked on photo.

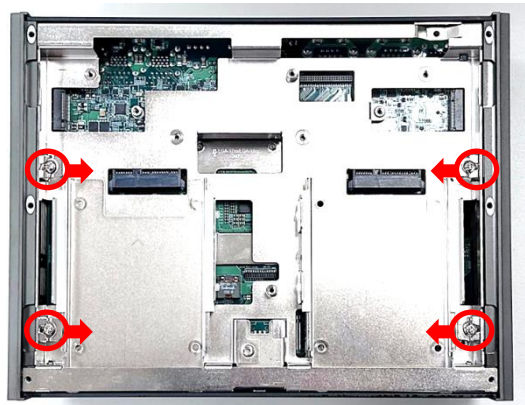

Step 4. Hold front and rear panel together and then remove the system body from the top cover.



Step 5. Place the system body aside gently.



3.2 Installing CPU



WARNING
(AVERTIR)

After replacing the CPU, please perform a Clear CMOS before powering on. According to Intel documentation (Clear CMOS after Hardware Configuration Change, Document Number: 337986-001), if you do not perform a Clear CMOS, the BIOS will apply settings from the old CPU to the new CPU, which may cause performance issues or startup failures. Therefore, Cincoze performs a Clear CMOS procedure before shipping. When customers power on the system for the first time, it will take several minutes to start. This is normal. During this process, the system will POST three times, and the Power LED will alternate between green and blue lights.

(Après avoir remplacé le CPU, veuillez effectuer un Clear CMOS avant de mettre sous tension. Selon la documentation Intel (Clear CMOS after Hardware Configuration Change, Document Number: 337986-001), si vous n'effectuez pas un Clear CMOS, le BIOS appliquera les paramètres de l'ancien CPU au nouveau CPU, ce qui peut entraîner des problèmes de performance ou des échecs de démarrage. Par conséquent, Cincoze effectue une procédure de Clear CMOS avant l'expédition. Lorsque les clients mettent le système sous tension pour la première fois, il faudra plusieurs minutes pour démarrer. Cela est normal. Pendant ce processus, le système effectuera trois fois le POST et la LED d'alimentation alternera entre les lumières verte et bleue.)

Step 1. Locate the CPU socket.

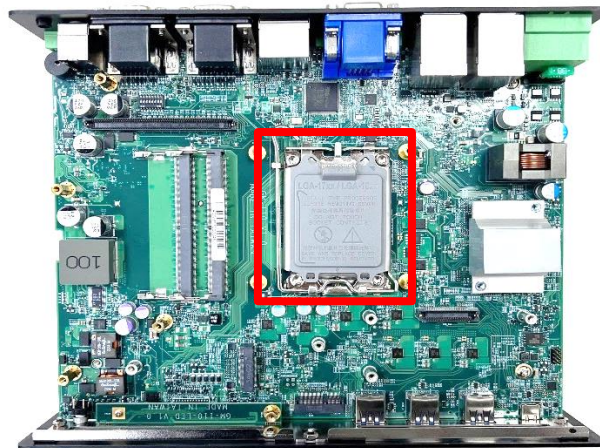

Step 2. Press and pull the lever to the side; it will then automatically bump up, unlocking the socket cover.



Step 3. Lift the lever to the fully open position as shown below.



Step 4. Hold the end of the lead connected to the socket cover and lift it to the fully open position, as shown below.

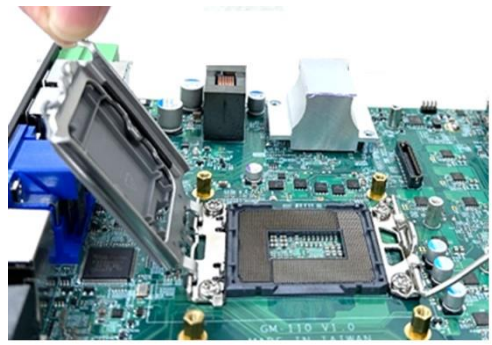

Step 5. Locate the notches of the socket. Then hold the CPU by the edges and put on the CPU gently with aligning the notches of the socket.

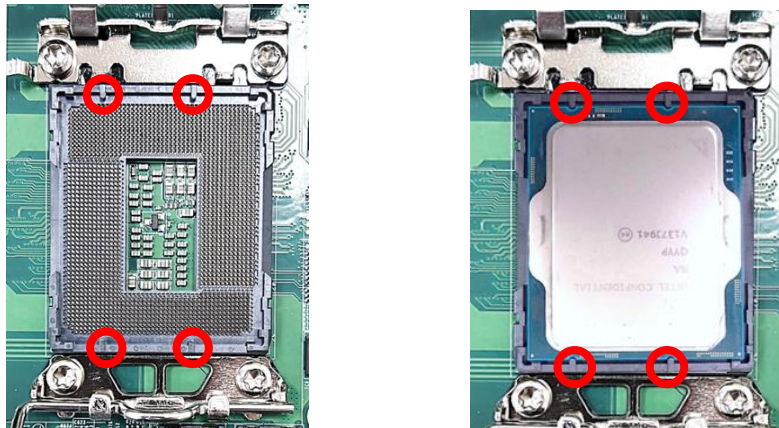

Step 6. Hold the end of the lead connected to the socket cover to press down the socket cover.



Step 7. Keep pressing the end of the lead and press down to lock the lever simultaneously. During this process, the cover will automatically pop up, as shown below.

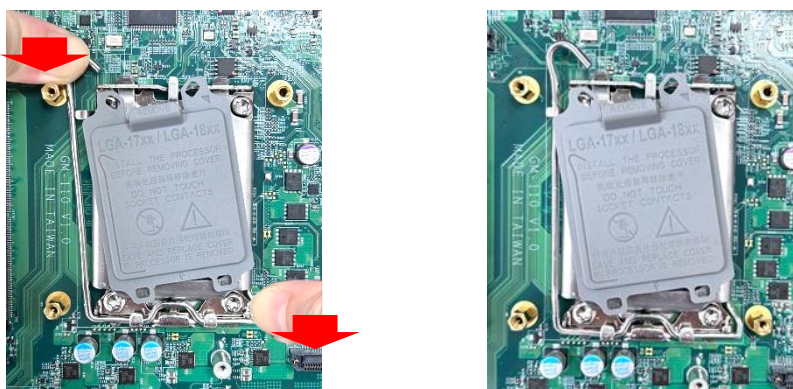

Step 8. Make sure that the CPU surface is clean, and apply the thermal paste (included in the CPU Installation Kit) onto the CPU's surface as shown below. For more detailed information about the thermal paste application, please find the [Intel official website](#).



Step 9. Aim at the four mounting holes and put on the CPU thermal block (included in the package). Then fasten four screws (M3x8L, Round Head, included in the screw pack) as shown below. Please note: the sign “▽ Front” means to face the side of the thermal block to the front panel.

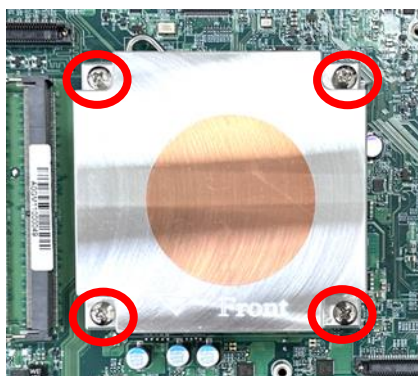

Step 10. Peel off the protective film from one side of the Thermal Pad (included in the package).

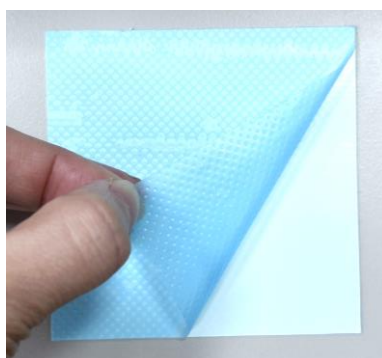

Step 11. Place the thermal pad onto the CPU heatsink, ensuring the peeled side faces downward.

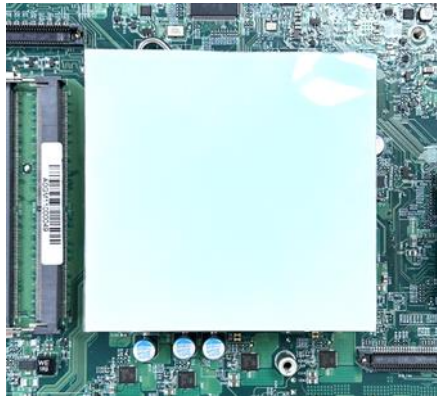

Step 12. Remove the transparent protective film from the other side of the Thermal Pad to complete the installation.

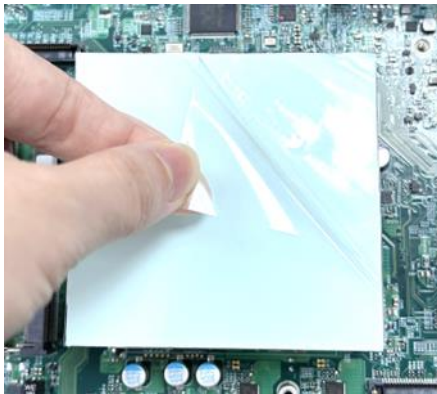

CAUTION
(ATTENTION)

Before assembling the system's chassis cover, please make sure the protective films on the Thermal Pad have been removed!
(Avant d'assembler le couvercle du châssis du système, assurez-vous que le film protecteur sur le coussin thermique a été retiré !)

3.3 Installing SO-DIMM

Step 1. Locate the SO-DIMM sockets on the top side of system.

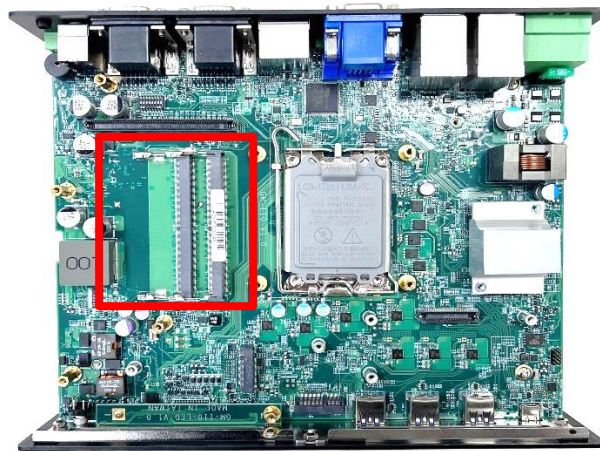

Step 2. Align the SO-DIMM notch with the socket notch. Insert it at a 45-degree angle until the edge connector is securely connected to the SO-DIMM socket.



Lower socket

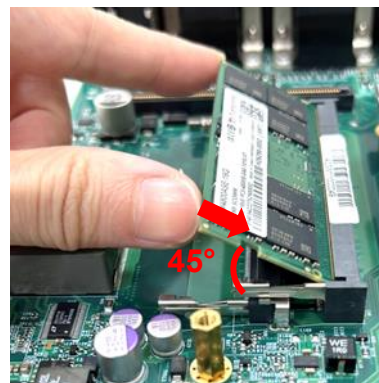

Upper socket

Step 3. Press down the module until the retaining clips snap back in place.



Lower socket

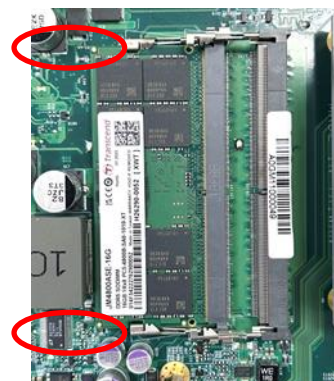

Upper socket

3.4 Installing M.2 Key B Module

3.4.1 M.2 Key B type 3052 Socket

3.4.1.1 M.2 Key B type 3052 Module

Step 1. Locate the M.2 Key B type 3052 connector (CN12) on the top side of the system motherboard.

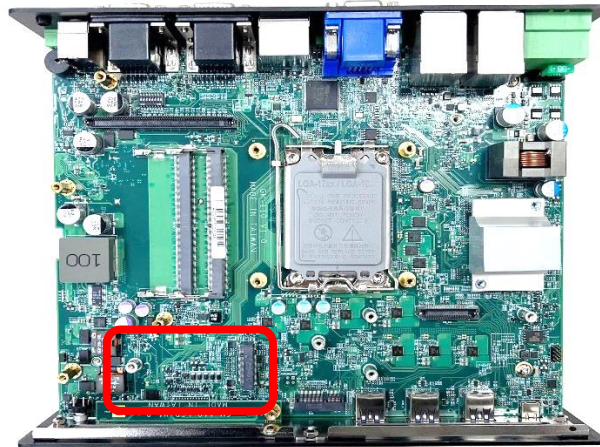

Step 2. Insert the M.2 Key B type 3052 module at a 45-degree angle and insert it to the slot until the gold-pated connector of module contacted firmly with the slot.



Step 3. Press down the module and fasten the screw to secure the module. (M3X5, included in the Screw Pack).



3.4.1.1 M.2 Key B type 3042/2242 Module

In this section, we will use the M.2 Key B 2242 module as an example for installing demonstration.

Step 1. Locate the M.2 Key B type 3052 connector (CN12) on the top side of the system motherboard.

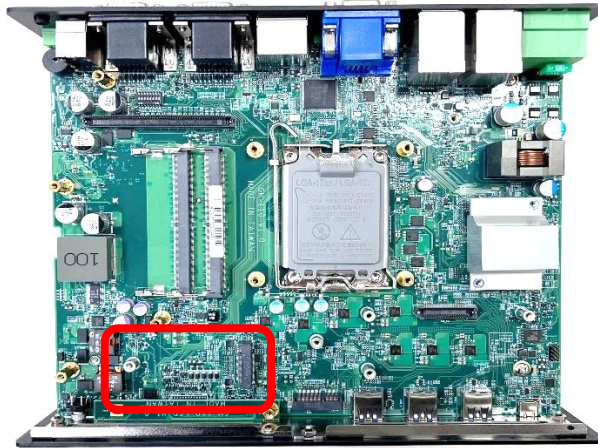

Step 2. Align the M.2 Key B Type 3052 to 3042 Adapter Bracket (included in the Package) with the corresponding screw hole. Secure the bracket in place and fasten the screw (M3x4, included in the Screw Pack).



Step 3. Insert the M.2 Key B module at a 45-degree angle and insert it to the slot until the gold-pated connector of module contacted firmly with the slot.

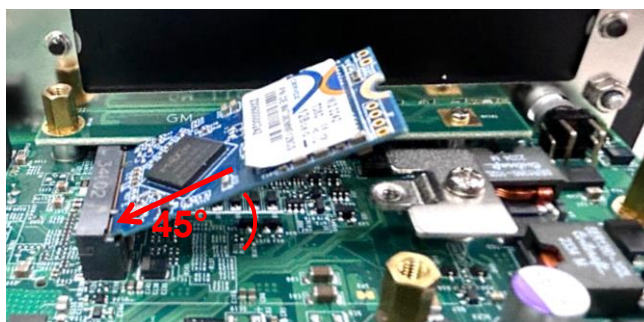

Step 4. Press down the module and fasten the screw to secure the module. (M3X5, included in the Screw Pack).



3.4.2 M.2 Key B type 2242 Socket

Step 1. Locate the M.2 Key B type 2242 connector (CN13 or CN14) on the bottom side of the system motherboard. (In this section, we will use CN13 connector as an example for installing the M.2 Key B 2242 module.)

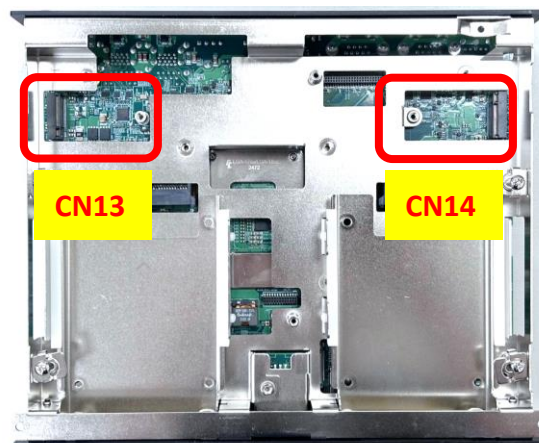

Step 2. Insert the M.2 Key B type 2242 module at a 45-degree angle and insert it to the slot until the gold-pated connector of module contacted firmly with the slot.

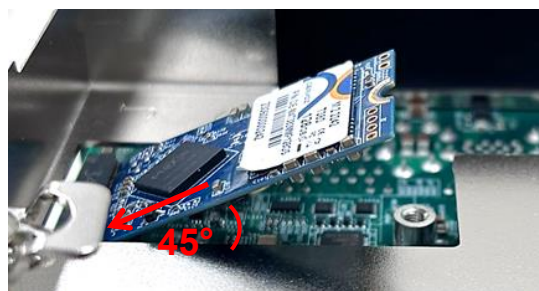

Step 4. Press down the module and fasten the screw to secure the module.



3.5 Installing M.2 Key E Module

3.5.1 M.2 Key E type 2230 Socket

Step 1. Locate the M.2 Key E connector (CN5) on the top side of the system motherboard.

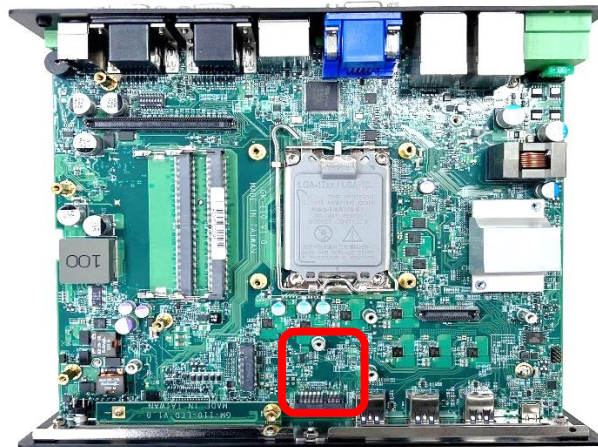

Step 2. Tilt the M.2 Key E module at a 45-degree angle and insert it to the socket until the golden finger connector of the card seated firmly.

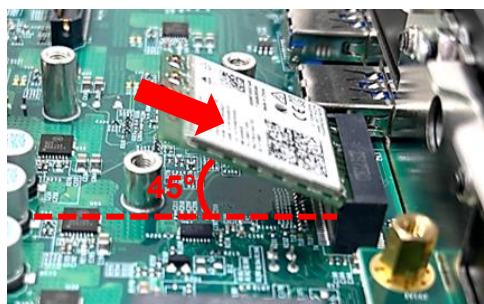

Step 3. Press the module down and secure it with the screw (M3X5, included in the Screw Pack).



3.6 Installing Antenna

Step 1. Remove the antenna rubber cover(s) on the rear panel of the system.



Step 2. For Antenna 1, penetrate the antenna jack through the hole.



For Antenna 2, loosen the screws on rear panel to remove the rear panel first, and place them aside for later use. Then penetrate the antenna jack through the hole.

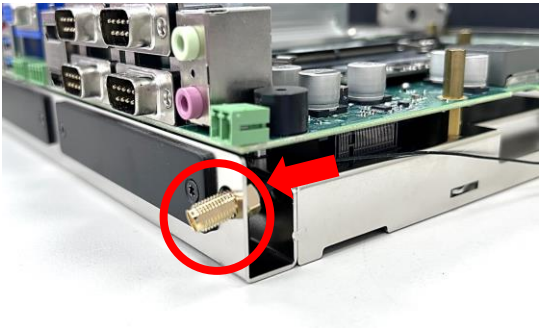
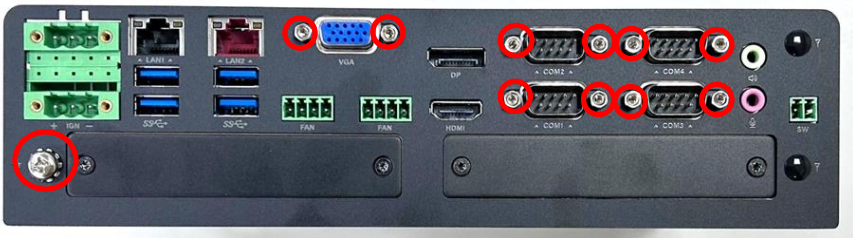

Step 3. For Antenna 1, put on the washer and fasten the nut of antenna jack.



For Antenna 2, put the rear panel back onto the system and fasten the screws removed previously. Then put on the washer and fasten the nut of antenna jack.



Step 4. Assemble the antenna and antenna jack together



Step 5. Remember to attach the RF connector of the cable's another end onto the wireless card after wireless card's installation.

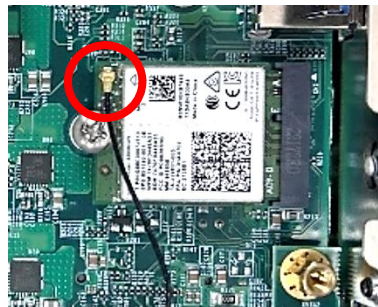

3.7 Installing Antenna Cutout Universal Bracket

An optional Universal Bracket (Model No. UB1332 for the front panel, UB0932 for the rear panel) features three antenna cutouts for 5G/4G card expansion. This bracket allows users to mount antennas in the designated cutouts. For installation details, refer to Chapter 3.6.

3.7.1 Front Panel

Step 1. Loosen and remove the two screws from either the left-side or right-side bracket of the system front panel (this example uses the left-side bracket for demonstration).



Step 2. Attach the I/O bracket on to the system as indicated below, and fasten the screws back to fix it. For guidance on antenna installation methods, please refer to chapter 3.6.



3.7.2 Rear Panel

Step 1. Loosen and remove the two screws from either the left-side or right-side bracket of the system rear panel (this example uses the left-side bracket for demonstration).



Step 2. Attach the I/O bracket on to the system as indicated below, and fasten the screws back to fix it. For guidance on antenna installation methods, please refer to chapter 3.6.



3.8 Installing MXM Module

Steps 1 to 4 introduce the installation method for the carrier board of the MXM module. Steps 5 to 10 detail the installation of the MXM module itself. In this section, we use the MXM-A2000 module as an example.

Step 1. Remove the two screws to remove the cover plate as indicated below.



Step 2. Locate the connector of MXM carrier board (J1) on the top side of system.

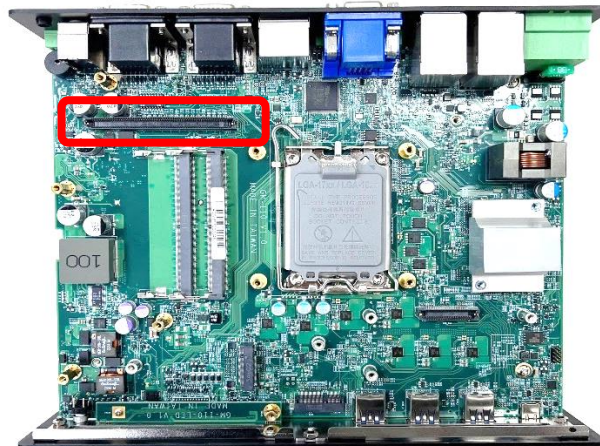

Step 3. Insert the MXM carrier board vertically to the connector on the system mainboard.



Step 4. Insert the MXM carrier board vertically to the connector on the system mainboard, and fasten the screws (M3x5L) as indicated below.

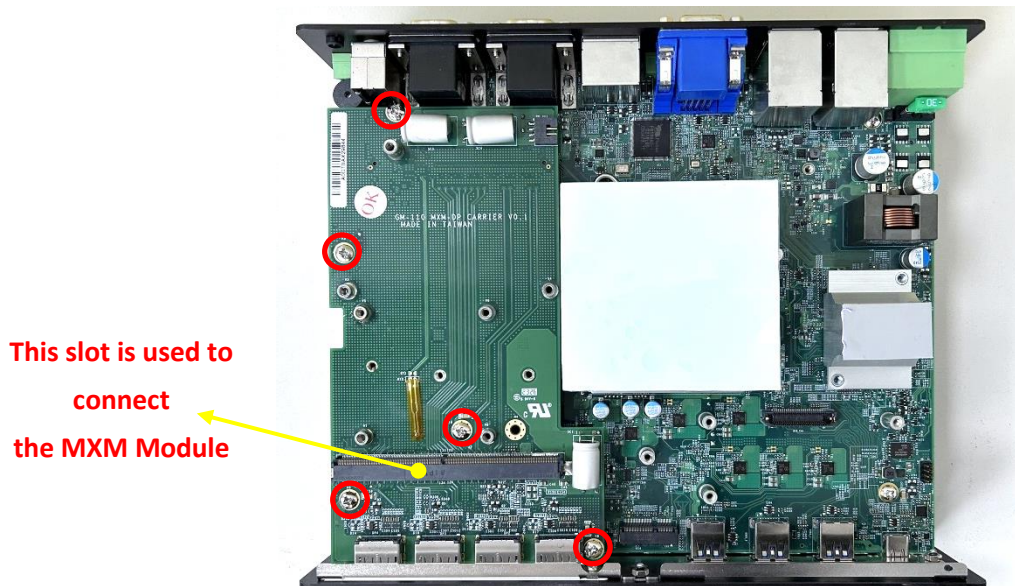

Step 5. Place the thermal pads on the chips of the MXM Module.

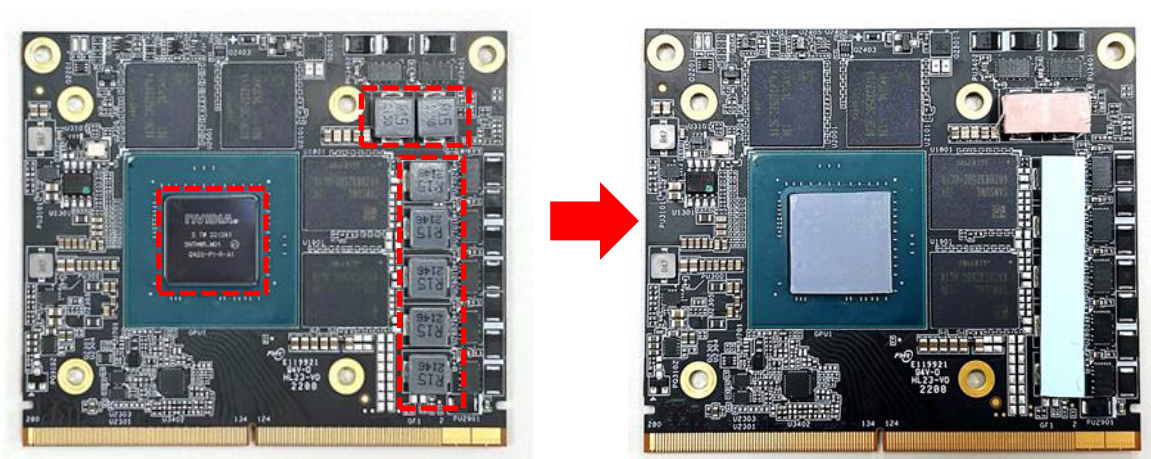

Step 6. Insert the MXM Module into the slot on the MXM carrier board at 45 degrees.

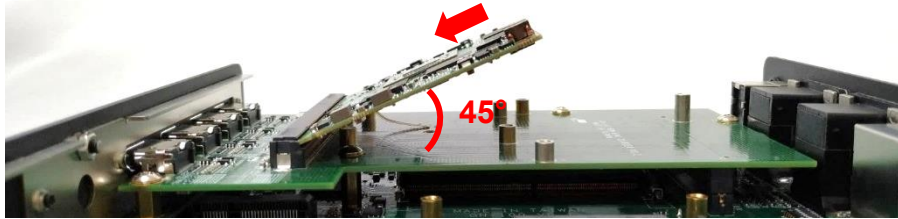

Step 7. Fasten the two screws (M3x5L).

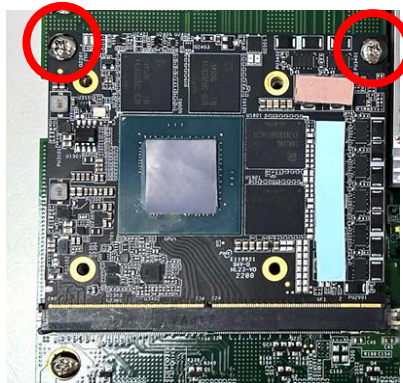

CAUTION
(ATTENTION)

Before putting on the thermal block (in the next step), please make sure the protective film on the Thermal Pad has been removed!

(Avant de poser le bloc thermique (à l'étape suivante), veuillez vous assurer que le film protecteur sur le coussinet thermique a été retiré !)

Step 8. Put on the thermal block with aligning the screw-holes, and fasten the 4 screws (M3x8L).

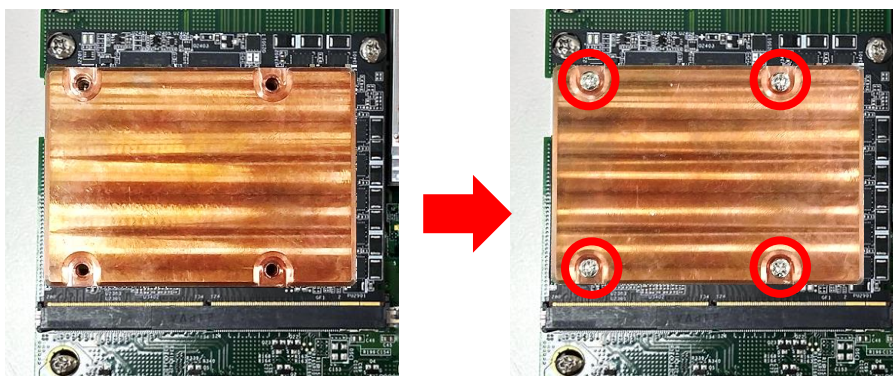

Step 9. Place the thermal pad on the thermal block.



**CAUTION
(ATTENTION)**

Before assembling the system's chassis cover, please make sure the protective film on the Thermal Pad has been removed!

(Avant d'assembler le couvercle du châssis du système, veuillez vous assurer que le film protecteur sur le coussinet thermique a été retiré !)

Step 10. Fix the accompanying bracket with 4x DP cutout by fastening the two screws back.



3.9 Removing Maintenance Area Panel

Step 1. Loosen the 2 screws on the Maintenance Area Panel and remove it.



3.10 Installing 2.5" SATA HDD/SSD

Step 1. Complete the instructions in Chapter 3.9 first, then return to this step. Loosen the screw(s) as shown below to remove the HDD bay cover bracket. (In this section, we will use the SATA2 connector as an example for installing a 2.5" SATA HDD/SSD.)



Step 2. Pull the rotating arm and pull the HDD bracket out of system.

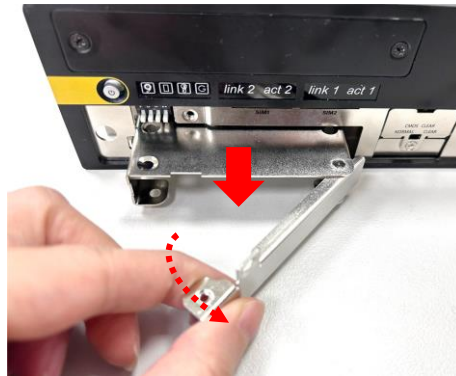

Step 3. Make the 2.5" SATA HDD/SSD bottom side face up, then place the HDD bracket on it. Ensure the bracket is oriented correctly as indicated below, and use the 4 provided screws (M3x4L, included in the Screw Pack) to securely attach them together.

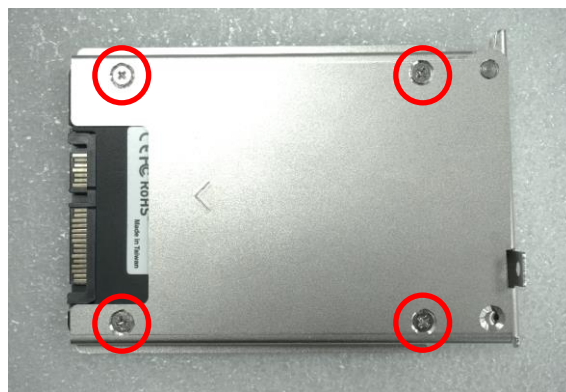

Step 4. Align the HDD bracket with the entrance of HDD bay. Insert the HDD bracket and push it until the HDD connector is fully inserted into the SATA slot.

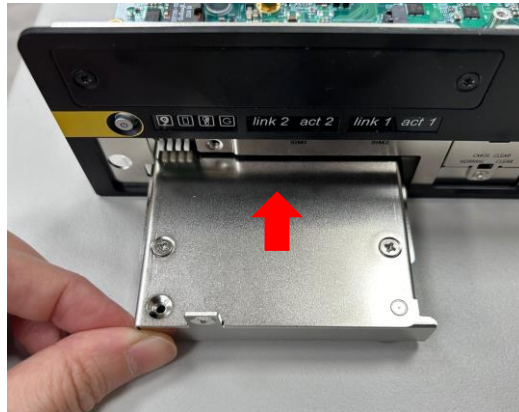

Step 5. Place the rotating arm back and fasten the screw.



3.11 Installing M.2 Key M Module

To install the M.2 Key M module, the user must first remove the hard drive bracket at SATA 2. Please follow steps 1 and 2 in Chapter 3.10 to remove the hard drive bracket, then return here to proceed with the M.2 Key M module installation.

Step 1. Locate the M.2 Key M connector (CN15) on the bottom side of the system motherboard.

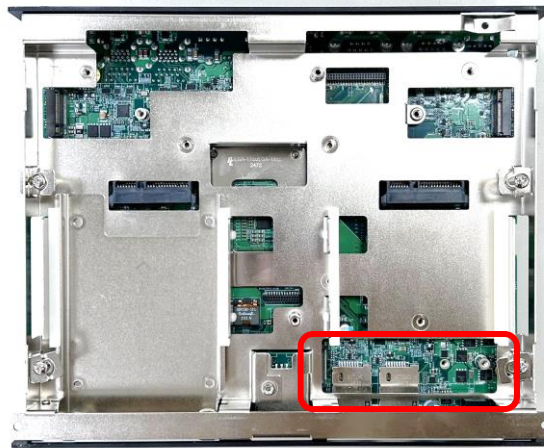

Step 2. Tilt the M.2 Key M module at a 45-degree angle and insert it to the socket until the golden finger connector of the card seated firmly.



Step 3. Press the module down and secure it with the screw (M3X5, included in the Screw Pack).



3.12 Installing SIM Card

Please refer to Chapter 3.4.1 to install a 5G/4G module before the SIM card installation for the SIM application.

Step 1. Locate the SIM card slots (SIM1 or SIM2) on the front side of the system.



Step 2. Insert a SIM card into SIM slot with the gold contacts facing up. Please pay attention to the insert orientation as illustrated. Please note if both SIM slots are installed with SIM cards, the network connection will prioritize the card at SIM1.

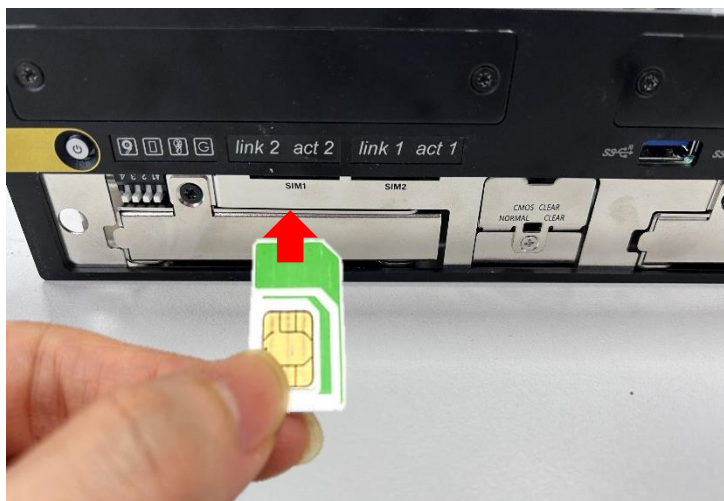

3.13 Installing CMI Module

3.13.1 CMI-LAN01/UB1312

Step 1. Loosen the 2 screws on the front panel to remove the cover plate.



Step 2. Locate the CMI module connector (BTB_FH4) on the top side of the system.

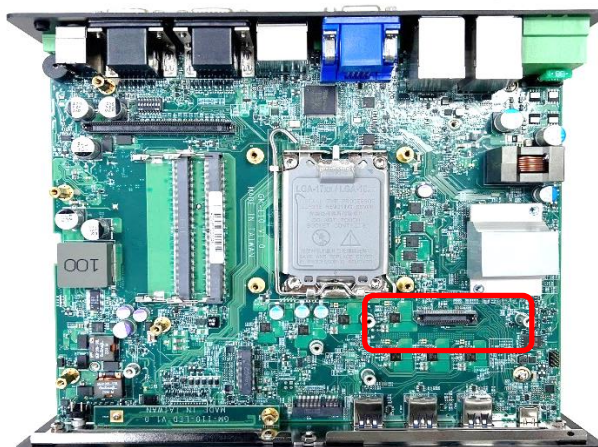

Step 3. Replace the screw with a copper pillar before inserting the CMI module.

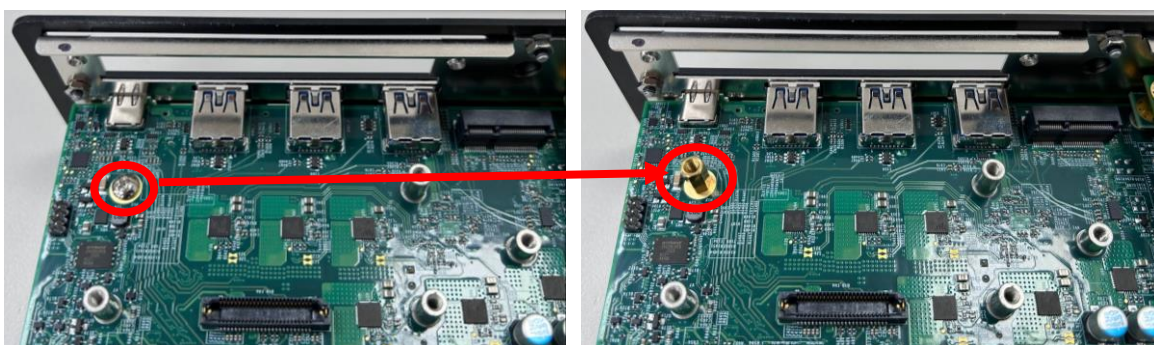

Step 4. Insert the CMI module vertically into the female connector on the system mainboard.

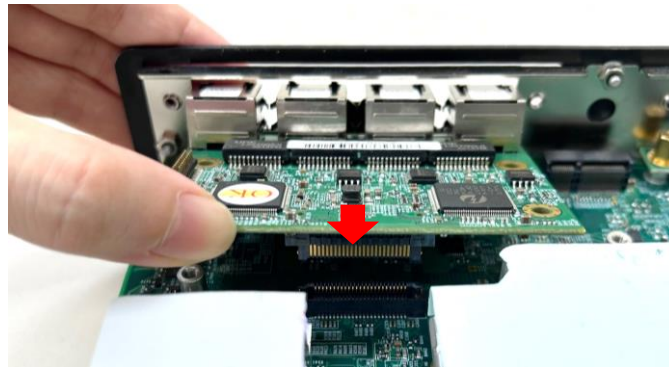

Step 5. Fasten the 4 screws to fix it.

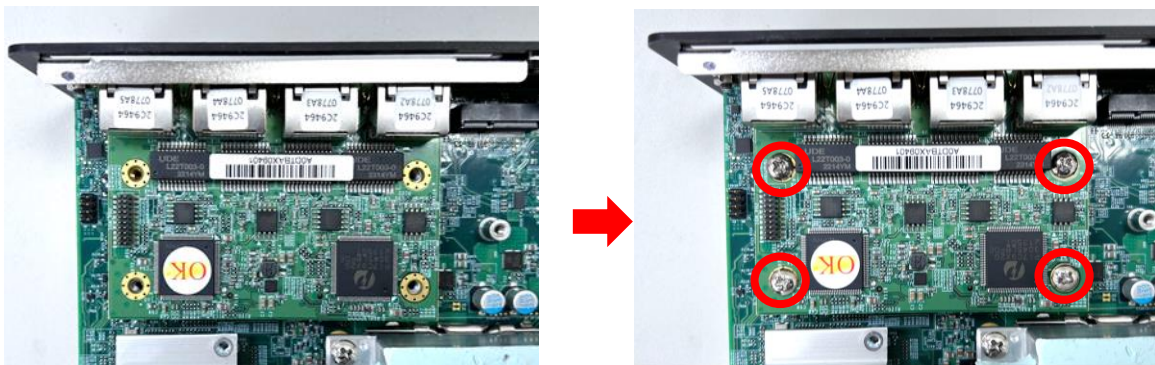

Step 6. Attach the I/O bracket, and fasten the two screws to secure it to the system.



3.13.2 CMI-2P5GLAN01/UB1312

Step 1. Loosen the 2 screws on the front panel to remove the cover plate.



Step 2. Locate the CMI module connector (BTB_FH4) on the top side of the system.

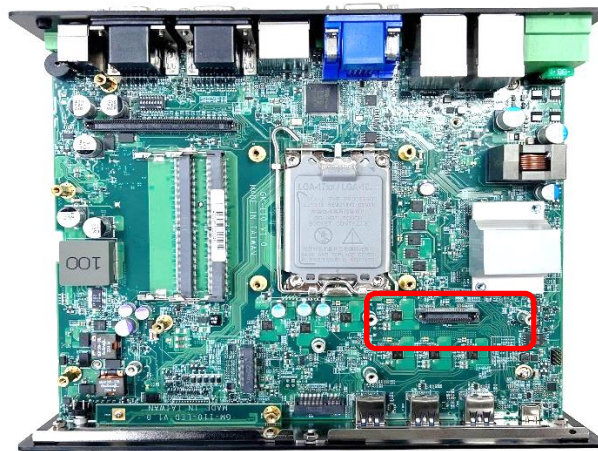

Step 3. Replace the screw with a copper pillar before inserting the CMI module.



Step 4. Locate the 5 chips on the CMI-2P5GLAN module indicated by the red squares below. Carefully apply thermal pads to each chip.

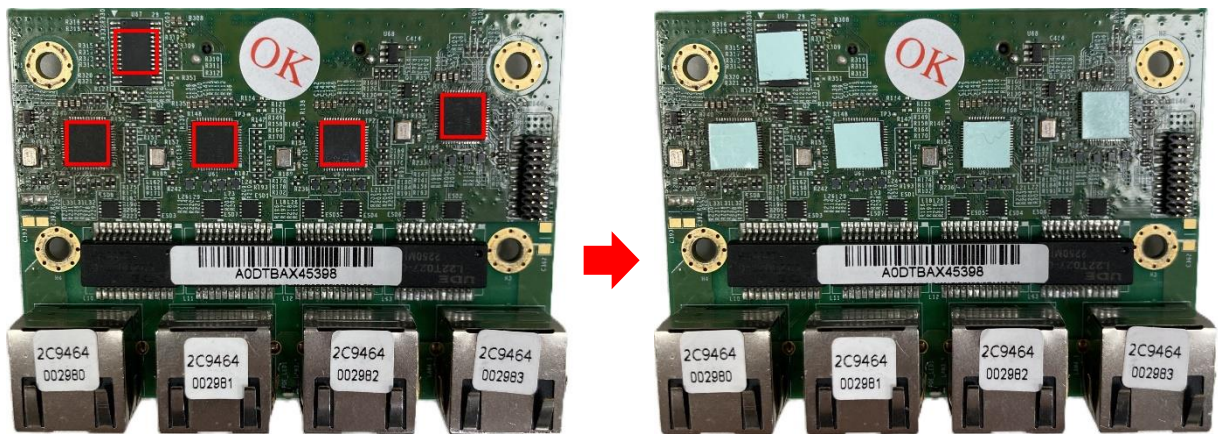

Step 5. Insert the CMI module vertically into the female connector on the system mainboard.

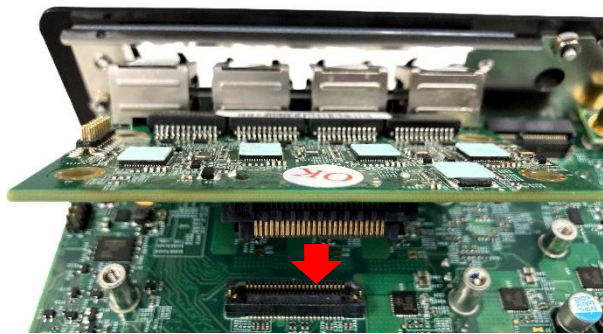

**CAUTION
(ATTENTION)**

Before installing the heatsink (in the next step), please make sure the protective films on both sides of the thermal pad have been removed!
(Avant d'installer le dissipateur thermique (à l'étape suivante), veuillez vous assurer que les films protecteurs des deux côtés du tampon thermique ont été retirés !)

Step 6. Align the heatsink protrusions with the chip pads on the CMI module and place it onto the module.

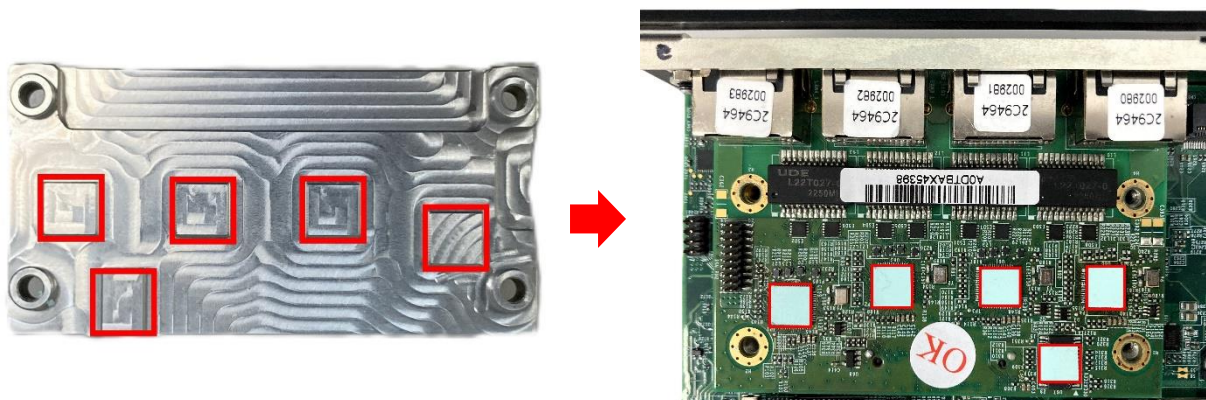

Step 7. Secure the CMI module to the motherboard using 4 screws as indicated below.

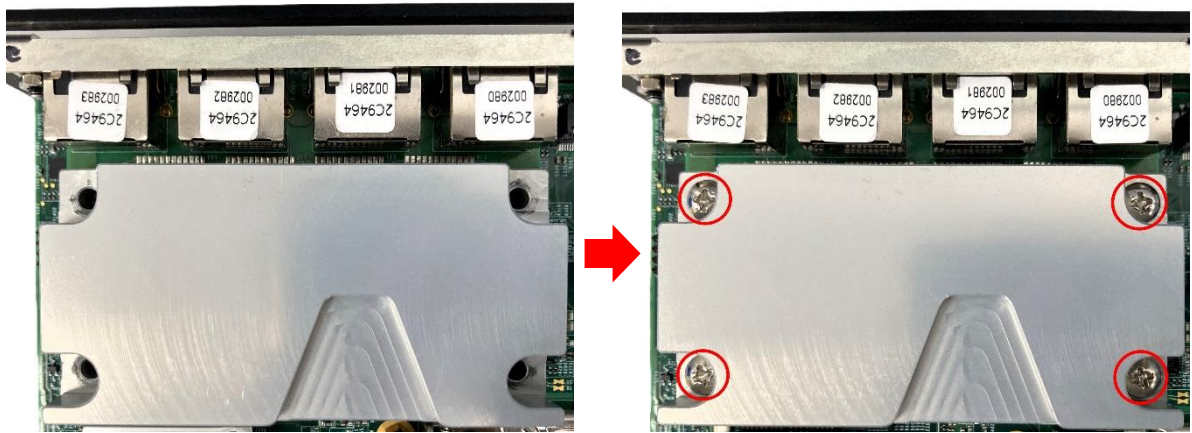

Step 8. Carefully apply a thermal pad to the heatsink.



CAUTION
(ATTENTION)

Before assembling the system, please make sure the protective films on both sides of the thermal pad have been removed!

(Avant d'assembler le système, veuillez vous assurer que les films protecteurs des deux côtés du pad thermique ont été retirés !)

Step 6. Attach the I/O bracket, and fasten the two screws to secure it to the system.

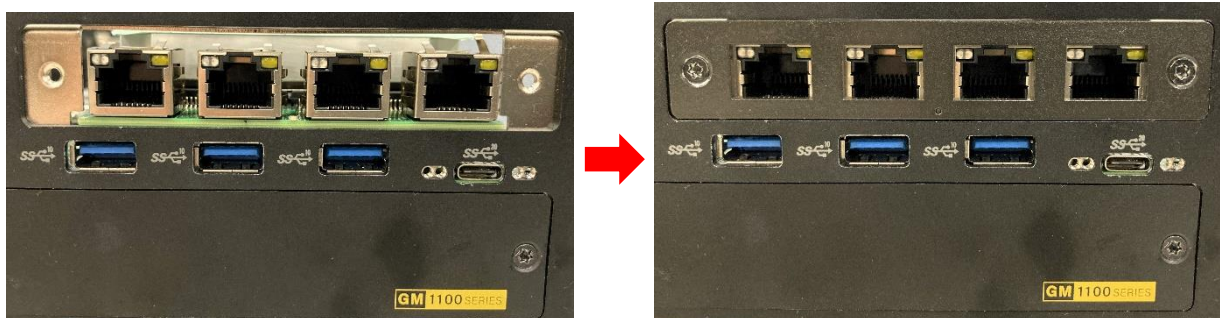

3.13.3 CMI-10GXM12LAN01/UB1337

Before installing the CMI-10GXM12LAN01/UB1337 module, users must first adjust the following BIOS settings. When entering BIOS, navigate to Chipset > PCH-IO, and change the [BTB_FH4 Mode Selection] setting from default mode [4x1] to mode [1x4].

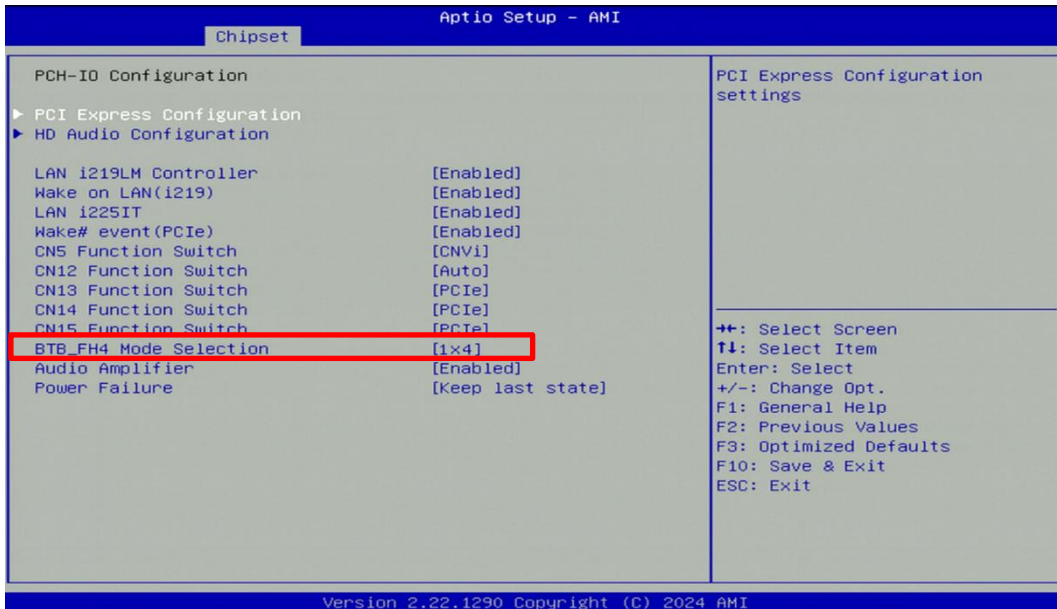

Step 1. Assemble the 10GXM12LAN bracket as indicated below: slot the hex rings through the XM12 I/O bracket and secure them from the inside with the hex nuts.

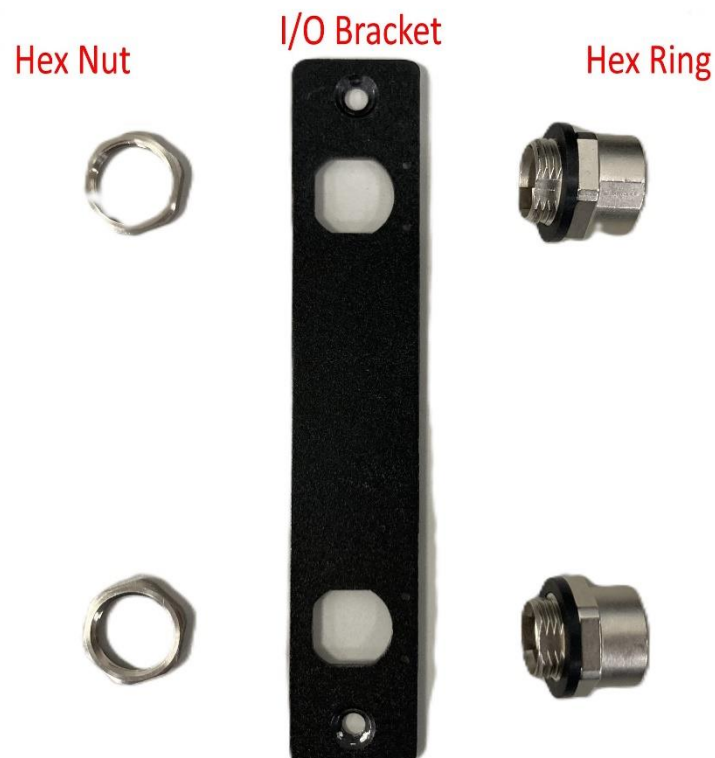

Step 2. Loosen the 2 screws on the front panel to remove the cover plate.



Step 3. Locate the CMI module connector (BTB_FH4) on the top side of the system.

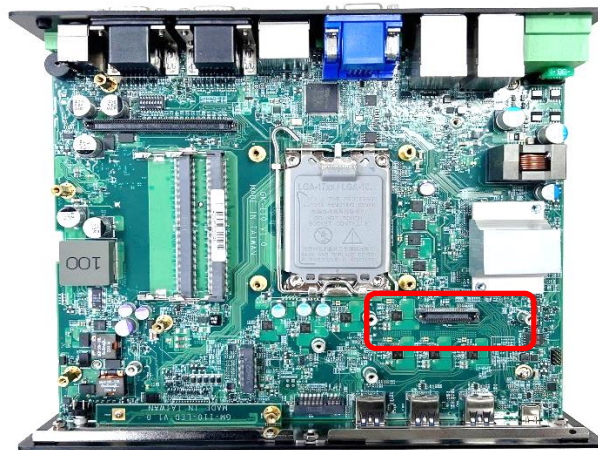

Step 4. Replace the screw with a copper pillar before inserting the CMI module.

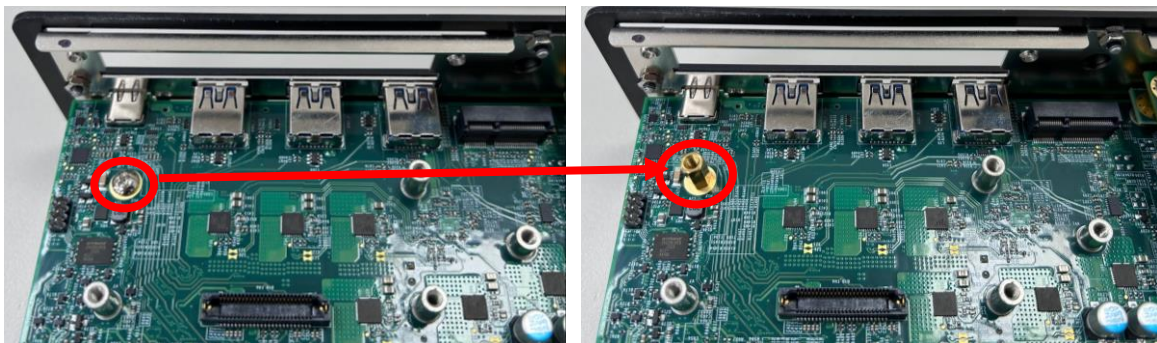

Step 4. Locate the chip on the 10GXM12LAN module indicated by the red square below. Carefully apply a thermal pad to the chip.

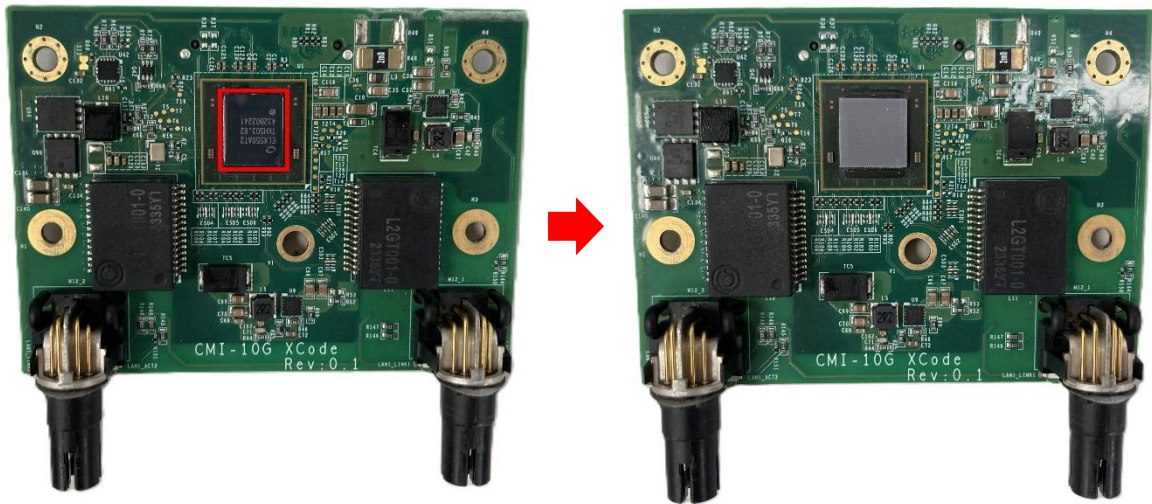

CAUTION
(ATTENTION)

Before installing the heatsink (in the next step), please make sure the protective films on both sides of the thermal pad have been removed!

(Avant d'installer le dissipateur thermique (à l'étape suivante), veuillez vous assurer que les films protecteurs des deux côtés du tampon thermique ont été retirés !)

Step 5. Install the heatsink and flip the module over. Secure the heatsink with a screw as indicated.

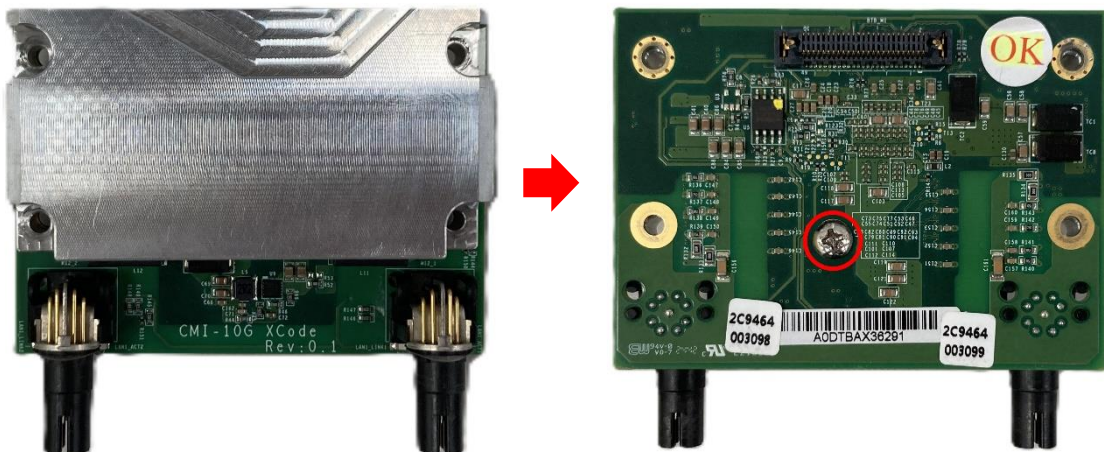

Step 6. Align the CMI module with the BTB connector and gently insert the module onto the motherboard. Secure the module to the motherboard using 4 screws as indicated below.

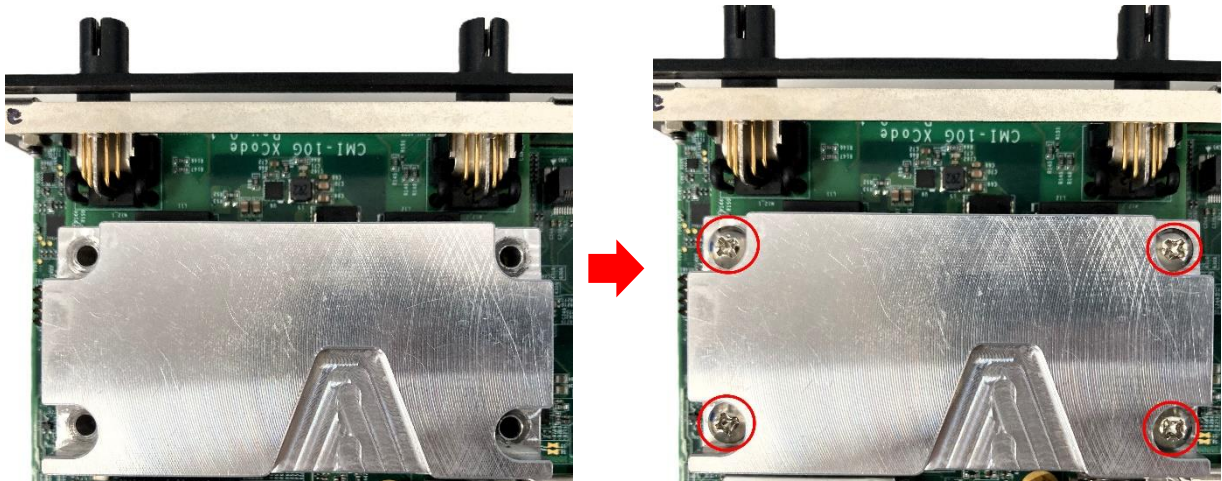

Step 7. Carefully apply a thermal pad to the heatsink.

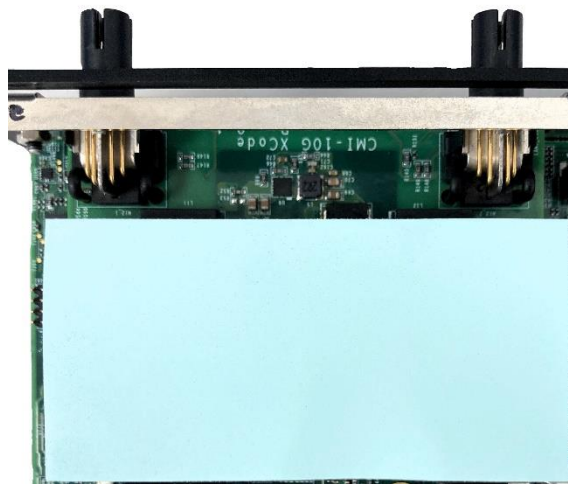

**CAUTION
(ATTENTION)**

Before assembling the system, please make sure the protective films on both sides of the thermal pad have been removed!

(Avant d'assembler le système, veuillez vous assurer que les films protecteurs des deux côtés du pad thermique ont été retirés !)

Step 8. Attach the I/O bracket, and fasten the two screws to secure it to the system.

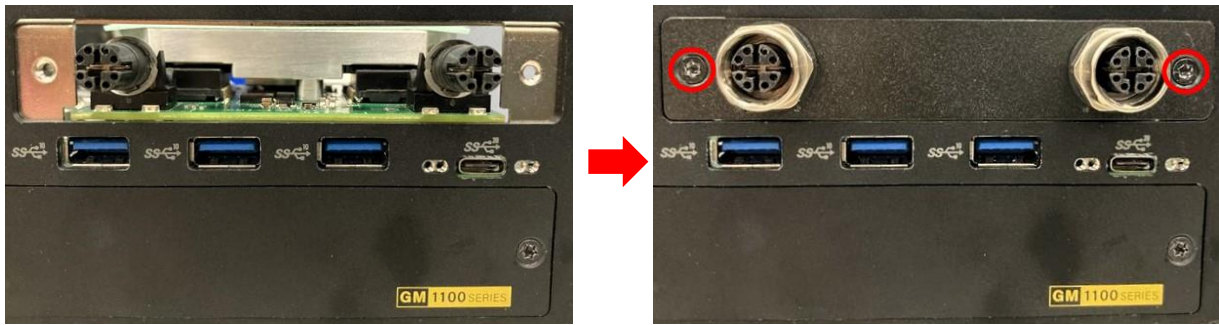

Step 9. Insert the rubber rings into the XM12LAN ports. Tweezers are recommended.

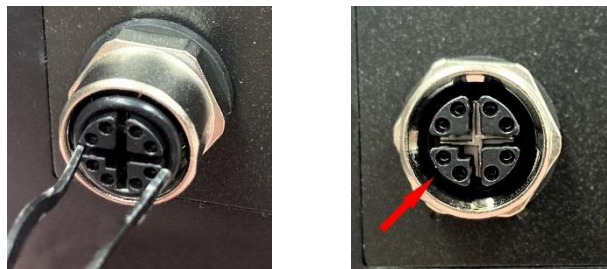

3.13.4 CMI-M12LAN01/UB1310

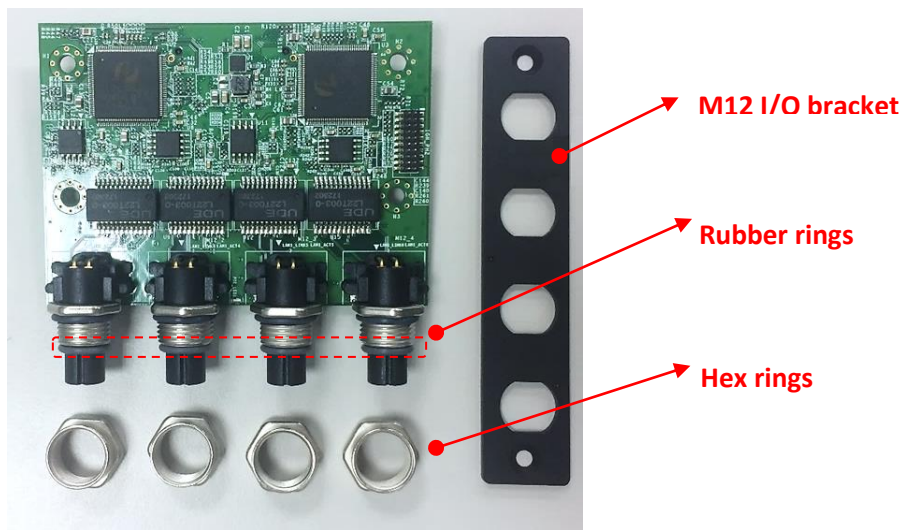

Step 1. Loosen the 2 screws on the front panel to remove the cover plate.



Step 2. Locate the CMI module connector (BTB_FH4) on the top side of the system.

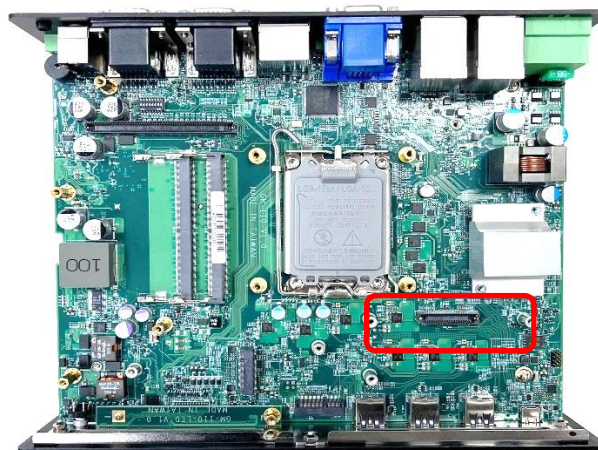

Step 3. Replace the screw with a copper pillar before inserting the CMI module.

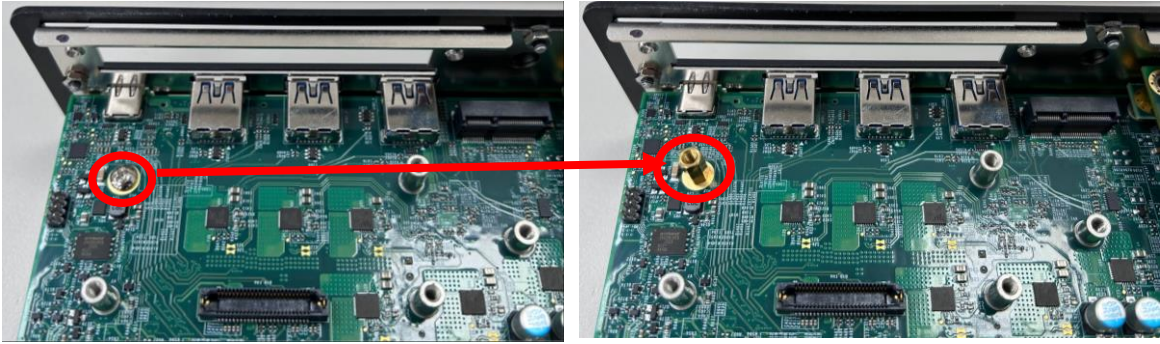

Step 4. Insert the CMI module vertically into the female connector on the system mainboard.



Step 5. Fasten the 4 screws to fix it.

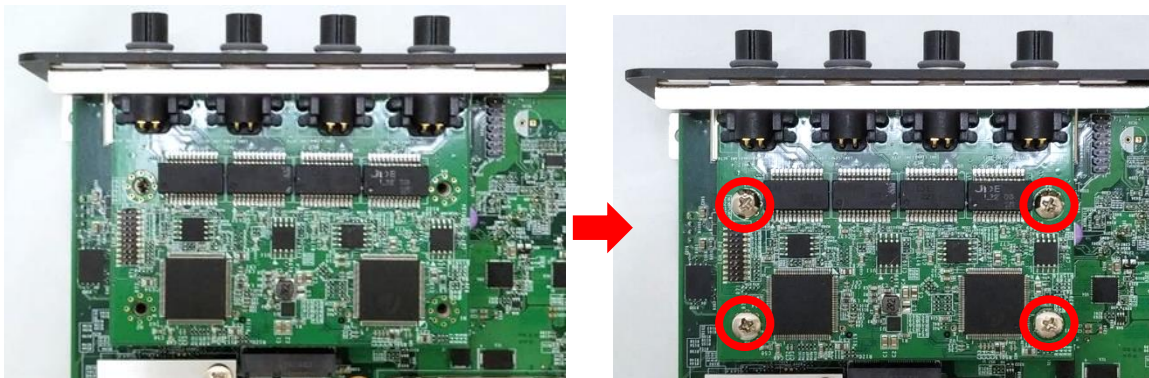

Step 6. Attach the I/O bracket, and fasten the two screws to secure it.

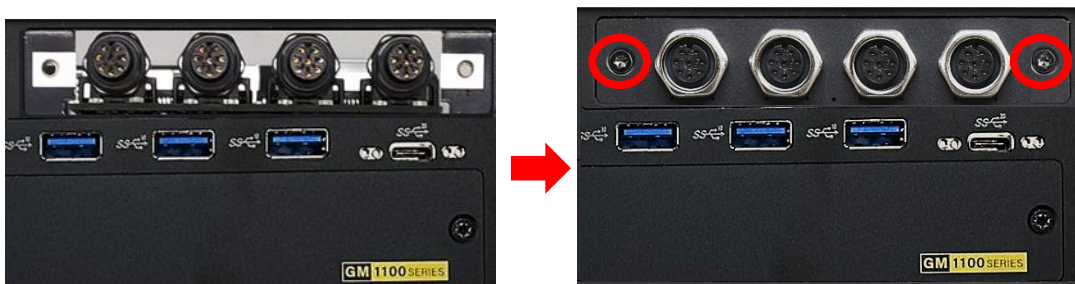

3.13.5 CMI-XM12LAN01/UB1330

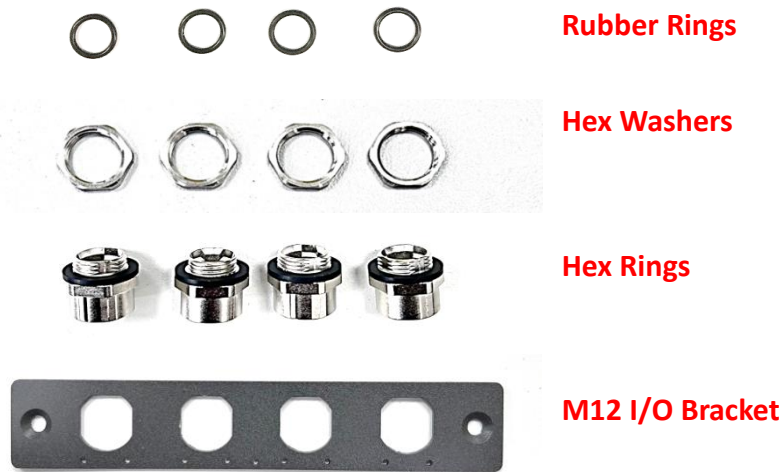

Step 1. Assemble the hex rings, M12 I/O bracket, and hex washers as indicated below: Penetrate the hex rings through the M12 I/O bracket holes, and fix them with hex washers.



Step 2. Loosen the 2 screws on the front panel to remove the cover plate.



Step 3. Locate the CMI module connector (BTB_FH4) on the top side of the system.

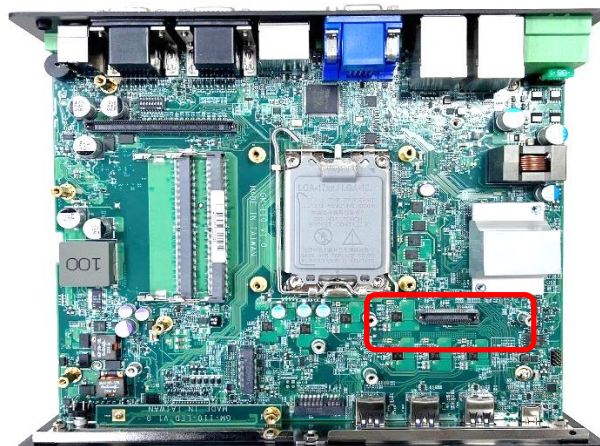

Step 4. Replace the screw with a copper pillar before inserting the CMI module.

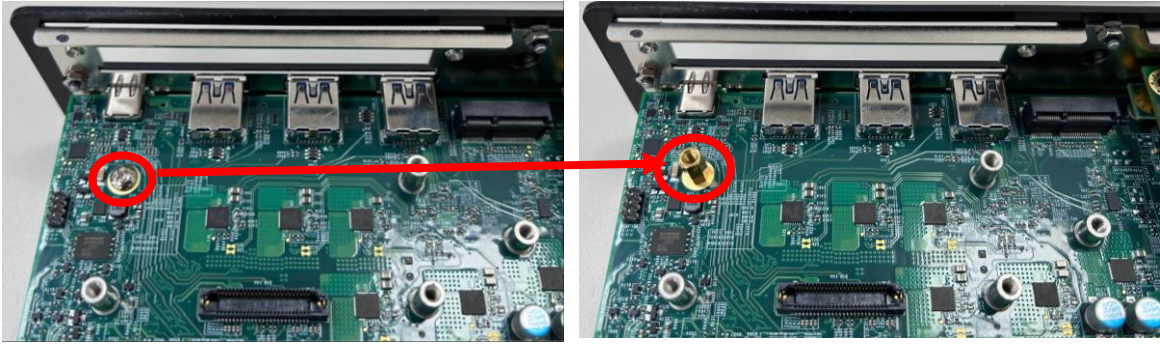

Step 5. Insert the CMI module vertically into the female connector on the system mainboard.

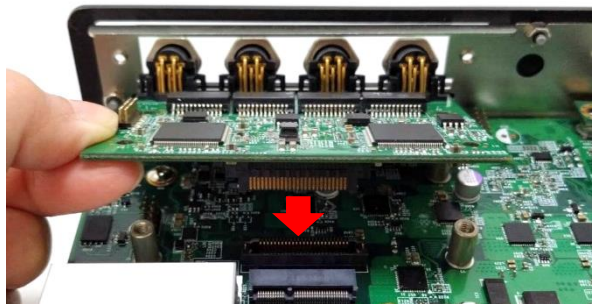

Step 6. Fasten the 4 screws to fix it.

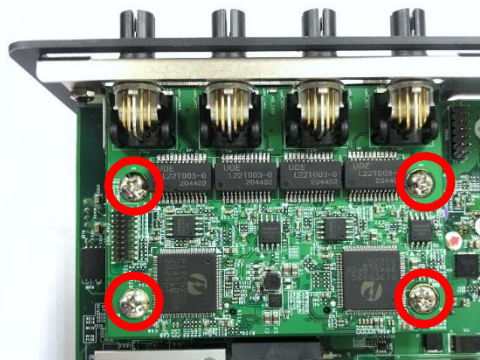

Step 7. Attach the assembled M12 I/O bracket to the system, and fasten the two screws.

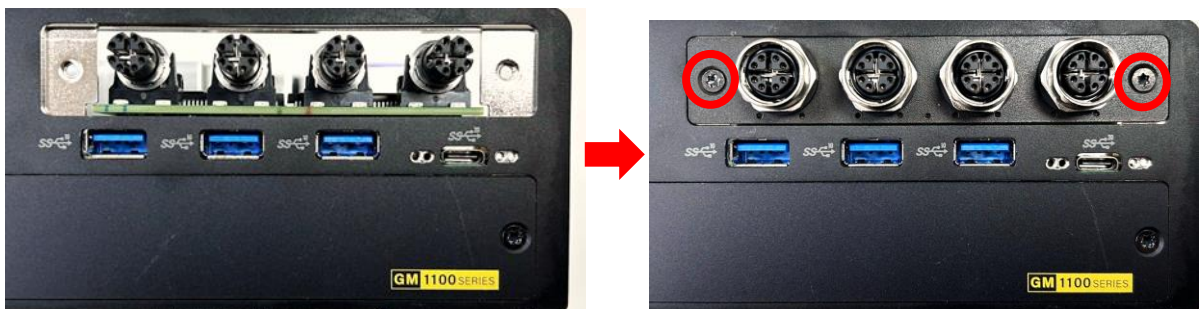

Step 8. Put the rubber rings onto each of the four M12 LAN ports.



3.13.6 CMI-10GLAN01/UB1328

Before installing the CMI-10GLAN01/UB1328 module, users must first adjust the following BIOS settings. When entering BIOS, navigate to Chipset > PCH-IO, and change the [BTB_FH4 Mode Selection] setting from default mode [4x1] to mode [1x4].

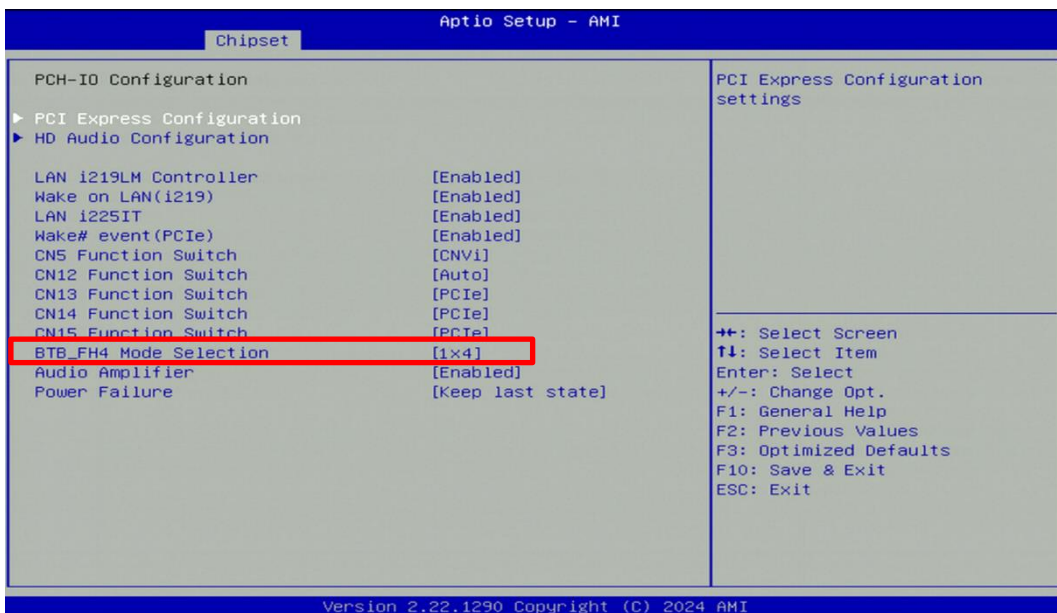

Step 1. Loosen the 2 screws on the front panel to remove the cover plate.



Step 2. Locate the CMI module connector (BTB_FH4) on the top side of the system.

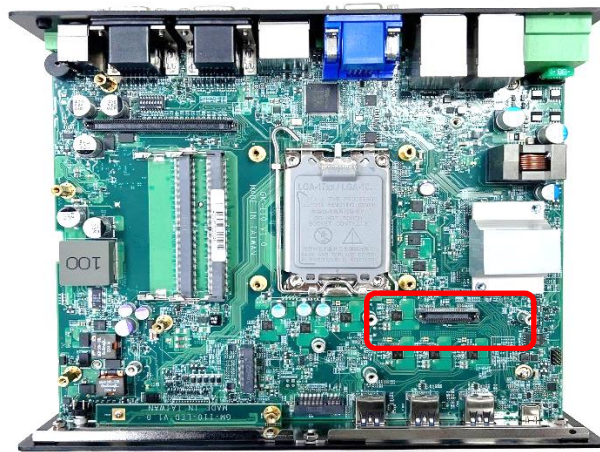

Step 3. Replace the screw with a copper pillar before inserting the CMI module.



Step 4. Locate the chip on the CMI-10GLAN01 module marked by the red square. Carefully paste the thermal pad onto the chip.

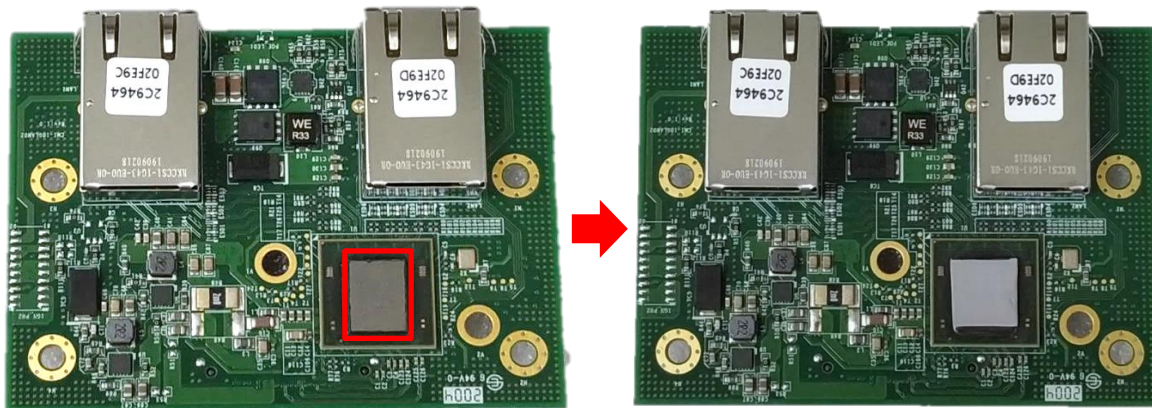

CAUTION
(ATTENTION)

Before putting on the thermal block (in the next step), please make sure the protective film on the Thermal Pad has been removed!

(Avant de poser le bloc thermique (à l'étape suivante), veuillez vous assurer que le film protecteur sur le coussinet thermique a été retiré !)

Step 5. Install the heatsink and flip the module over. Fasten the screw to fix the heatsink.

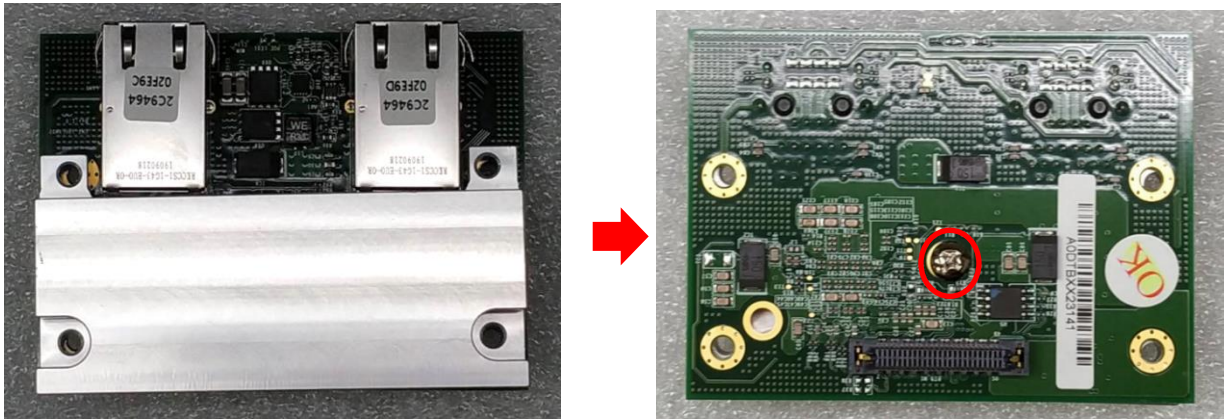

Step 6. Insert the CMI module vertically into the female connector on the system mainboard.

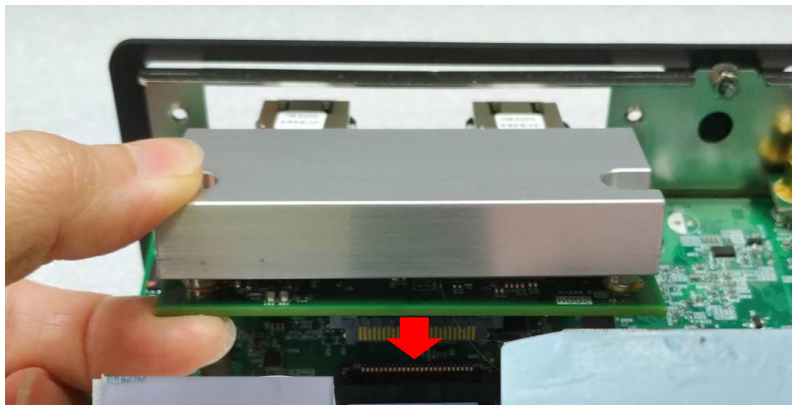

Step 7. Fasten the 4 screws indicated below to fix it.

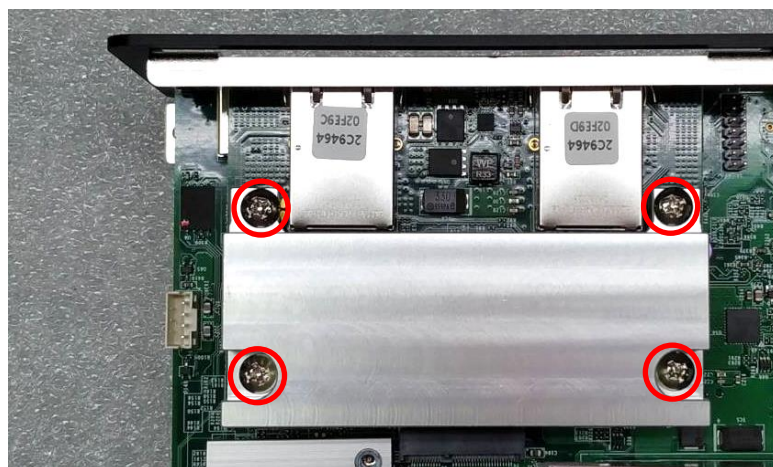

Step 8. Carefully paste the thermal pad onto the heatsink.



**CAUTION
(ATTENTION)**

Before assembling the system's chassis cover, please make sure the protective film on the Thermal Pad has been removed!

(Avant d'assembler le couvercle du châssis du système, veuillez vous assurer que le film protecteur sur le coussinet thermique a été retiré !)

Step 9. Attach the I/O bracket and fasten the two screws to secure it.



3.13.7 CMI-CAN01/UB1338

Step 1. Loosen the 2 screws on the front panel to remove the cover plate.



Step 2. Locate the CMI module connector (BTB_FH4) on the top side of the system.

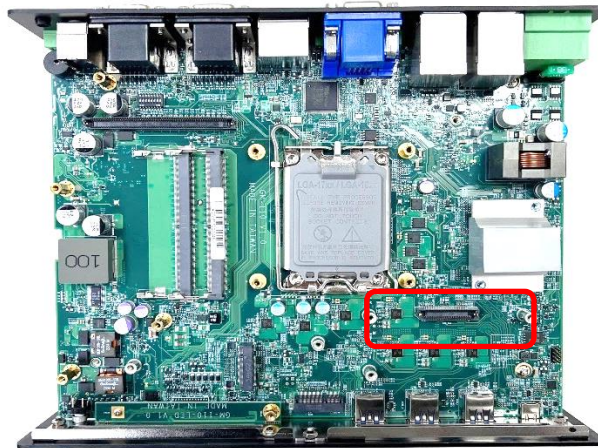

Step 3. Replace the screw with a copper pillar before inserting the CMI module.

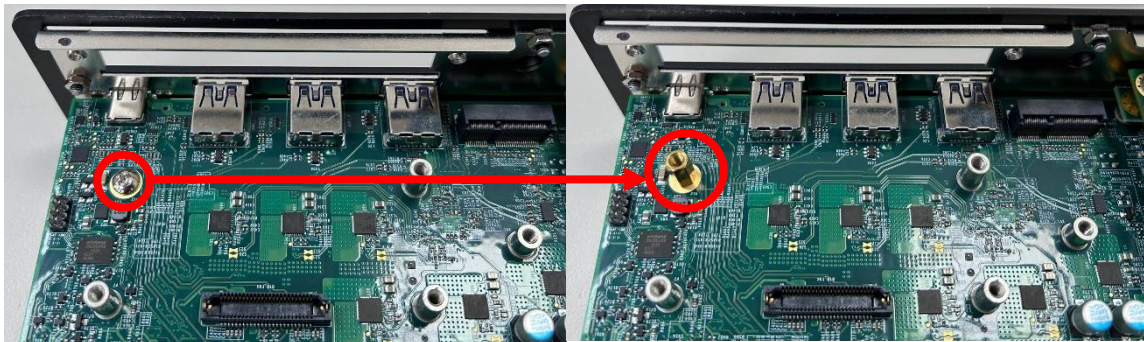

Step 4. Insert the CMI module vertically into the female connector on the system mainboard.

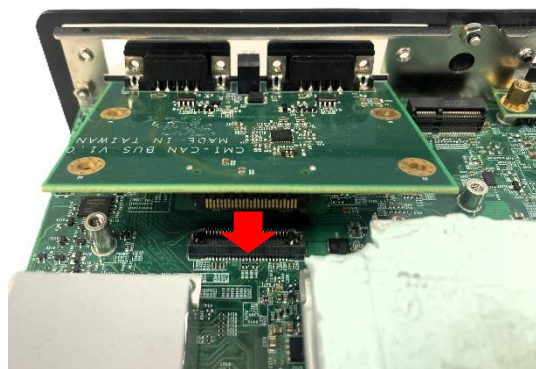

Step 5. Fasten the 4 screws indicated below to fix it.

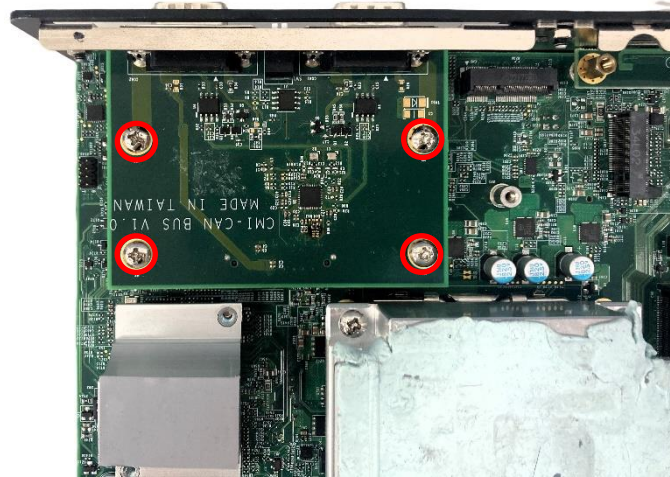

Step 6. Attach the I/O bracket and fasten the two screws to secure it.

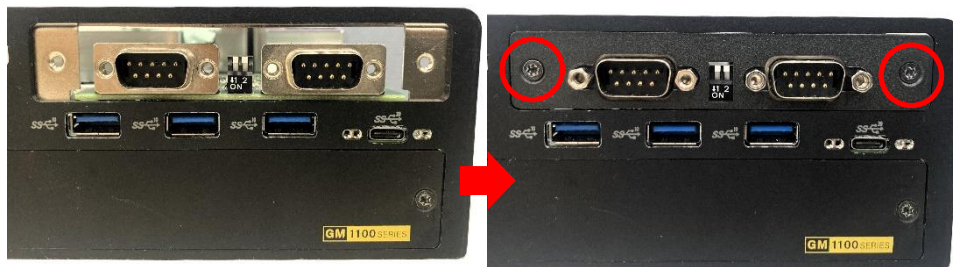

3.13.8 CMI-COM01/UB1303

For pin-out definitions related to this module, please refer to Chapter 2.5.5.

Step 1. Locate the CMI module connector (BTB_FH1) on the bottom side of the system.

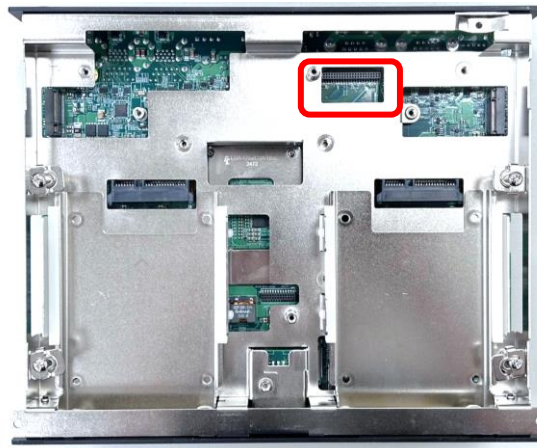

Step 2. Loosen the 2 screws on the rear panel to remove the cover plate



Step 3. Penetrate the CMI-COM module through the area with an inclined angle as indicated, and then insert the CMI-COM module carefully into the CMI connector.

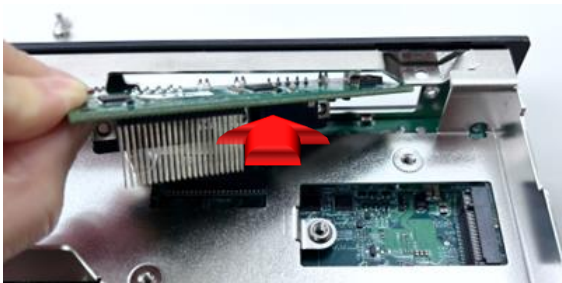

Step 4. Secure it with the two screws as indicated.



Step 5. Attach the CMI-COM bracket, and fasten the screws to fix it.

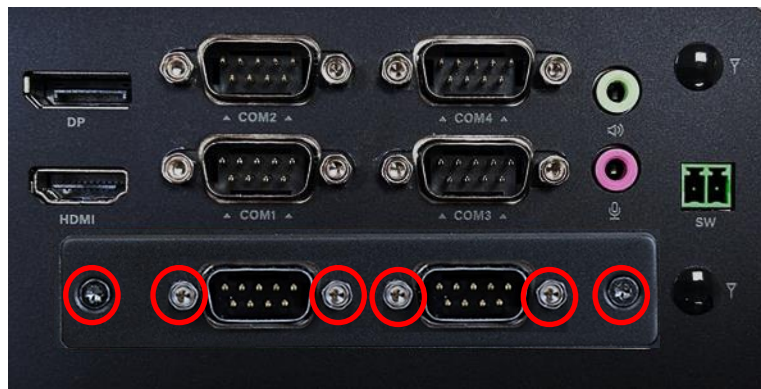

3.13.9 CMI-DIO01/UB1318

For pin-out definitions related to this module, please refer to Chapter 2.5.6.

Step 1. Locate the CMI module connector (BTB_FH1) on the bottom side of the system.

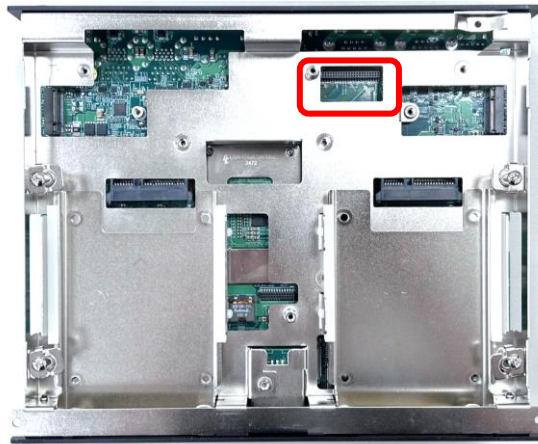

Step 2. Loosen the 2 screws on the rear panel to remove the cover plate



Step 3. Penetrate the CMI-DIO module through the area at an inclined angle, and then insert the CMI-DIO module carefully into the CMI connector.

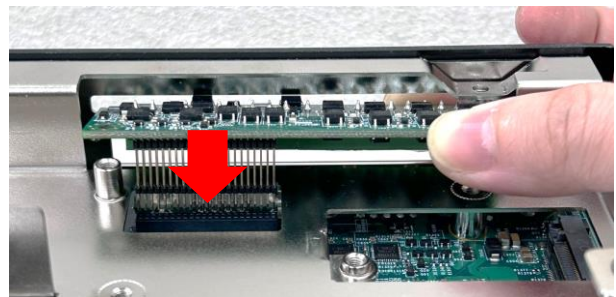
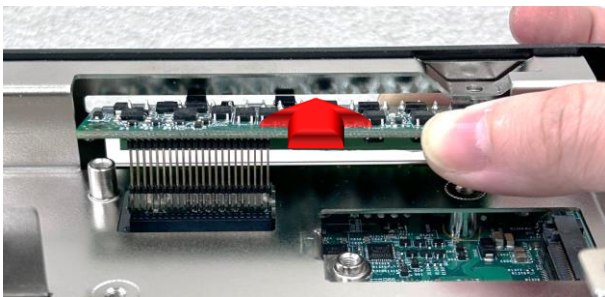

Step 4. Secure it with the two screws as indicated.

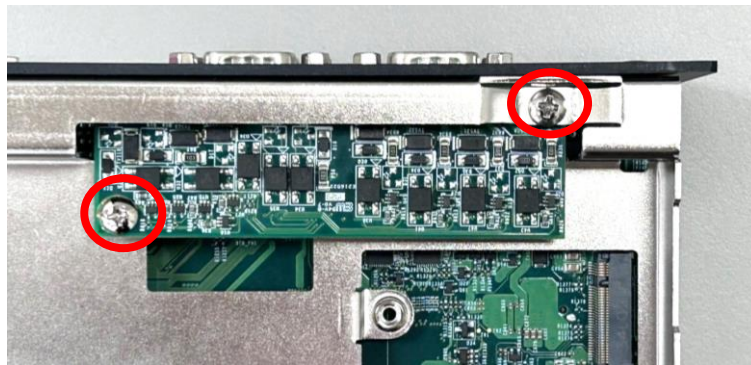

Step 5. Attach the CMI-DIO bracket and fasten it with the two screws.



3.14 Installing CFM Module

3.14.1 CFM-PoE01

The CFM-PoE module for the GM-1100 series is installed on the CMI-LAN01, CMI-M12LAN01, or CMI-XM12LAN01 module.

The photo example in this section is illustrated by CMI-M12LAN01/UB1310/CFM-PoE01 module. If you use a CMI-LAN module, you will note that the shading tape has been placed on the module; if not, please paste the shading tape to the place which was marked by red circle. If you use the other modules please skip this step. (Note: Do not make the tape block the LED.)

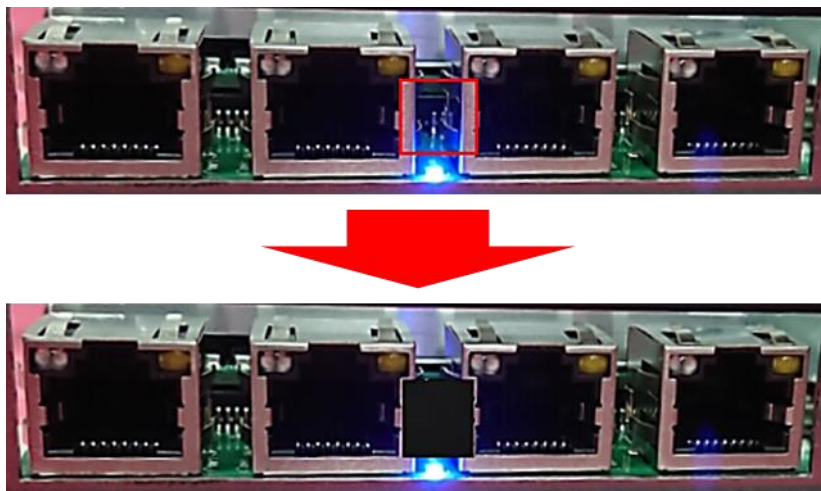

Step 1. Please execute steps 1 to 4 in section 3.13.2 in advance, and fasten 4 copper pillars to secure the module.

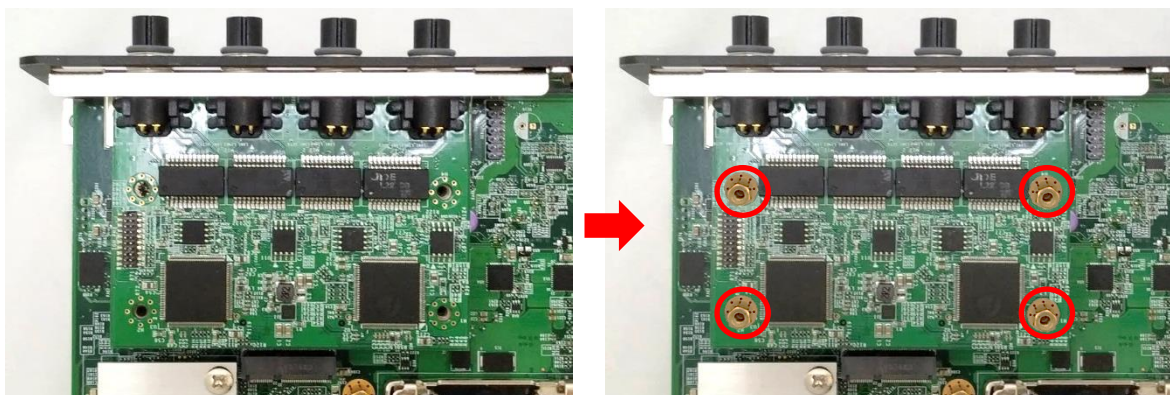

Step 2. Insert the CFM-PoE01 module vertically into the male connector of the CMI module until it's connected firmly.



Step 3. Turn over the heatsink of CFM-PoE01 and locate the two places marked by red squares. Carefully paste the two thermal pads for CFM-PoE01 onto the heatsink.

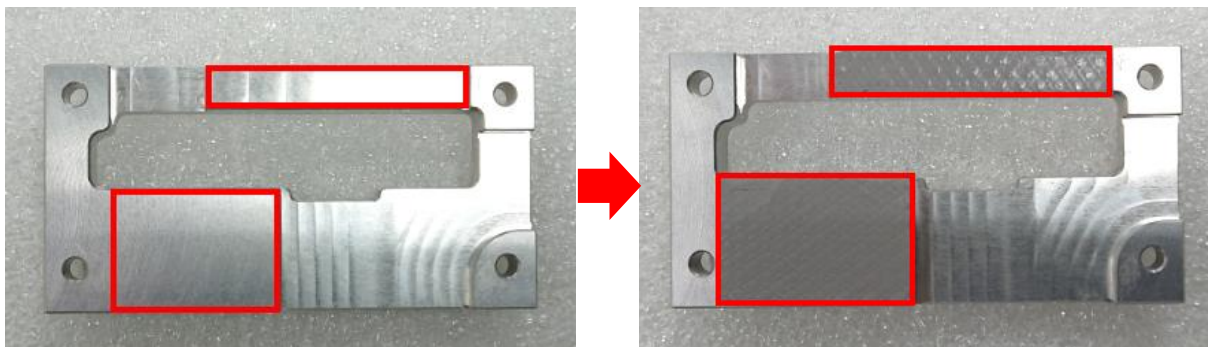

CAUTION
(ATTENTION)

Before putting on the thermal block (in the next step), please make sure the protective film on the Thermal Pad has been removed!

(Avant de poser le bloc thermique (à l'étape suivante), veuillez vous assurer que le film protecteur sur le coussinet thermique a été retiré !)

Step 4. Carefully place the heatsink onto the CMI-PoE module and connect the PoE module to the CMI-M12LAN module.



Step 5. Fasten 4 screws to fix it.

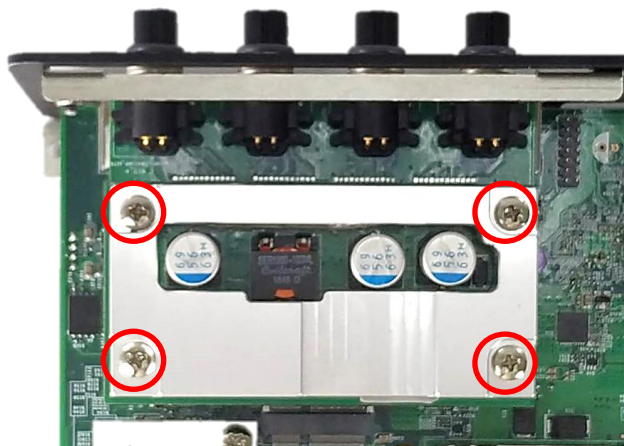

Step 6. Please select the yellow-blue thermal pad (one side is yellow and the other side is blue) from the module pack, and peel off the protective film on the blue side of the thermal pad first.



Step 7. Carefully attach the blue side of the thermal pad onto the heatsink, and then execute step 6 in section 3.13.2 to complete the installation.



CAUTION
(ATTENTION)

The yellow surface is part of the thermal pad. Do not tear it off as it would affect the thermal conductivity.

(La surface jaune fait partie du coussinet thermique. Ne la retirez pas, car cela affecterait la conductivité thermique.)

3.14.2 CFM-IGN01

For pin-out definitions related to this module, please refer to Chapter 2.3 (SW3 and 24V_12V_1).

Step 1. Locate the power Ignition connector (IGN_PH1) on the bottom side of the system motherboard as indicated.

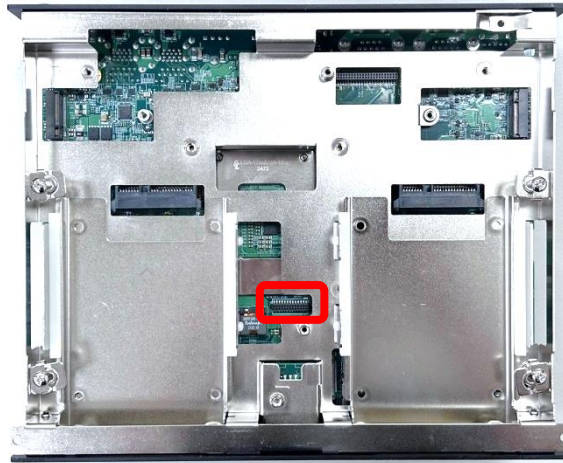

Step 2. Insert the connector of the power ignition board into the female connector on the motherboard. Ensure all the pins of the IGN module connector are firmly connected.

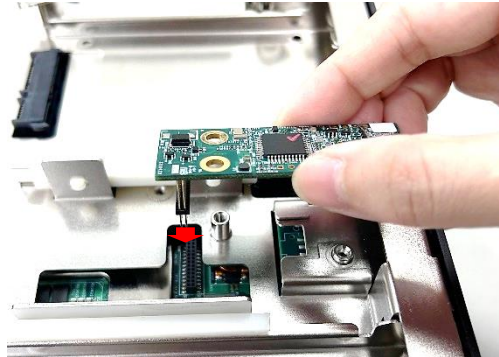

Step 3. Fasten two screws to secure the power ignition board.

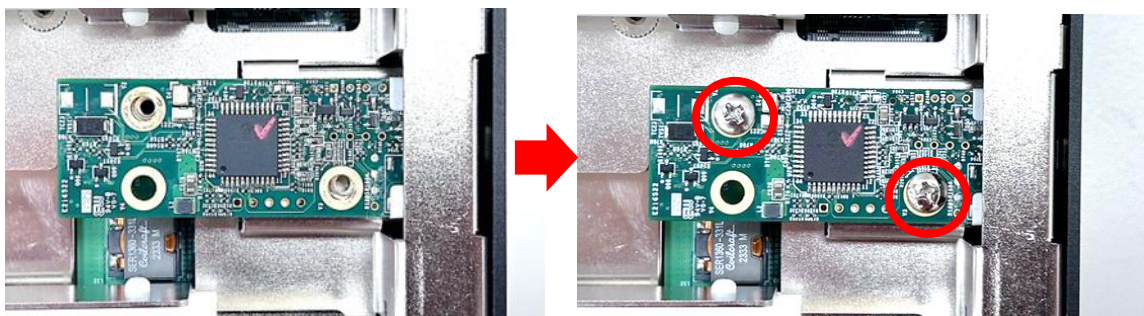

3.15 Installing Top Cover

Step 1. Hold the system body and reattach it to the top cover.



Step 2. Push the 4 latches back and fasten the 4 screws.

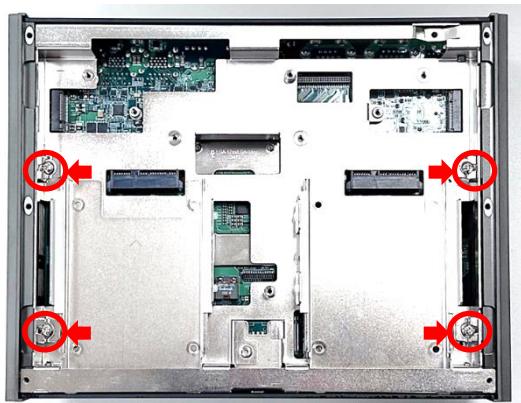

Step 3. Place the bottom cover on the chassis.



Step 4. Fasten the 6 screws back to the bottom cover.



3.16 Installing Maintenance Area Panel

Step 1. Fasten the screws as indicated to install the Maintenance Area Panel back to the system.



3.17 Installing Wall Mount Kit

This system offers wall mount Kit (2 brackets and 8 screws) for customers to install system on the wall in a convenient and economical way.

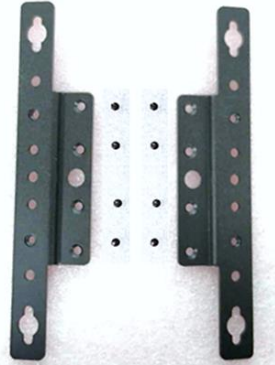

Step 1. The mounting holes are at the bottom side of system. Use provided 8 screws to fasten the bracket on each side.

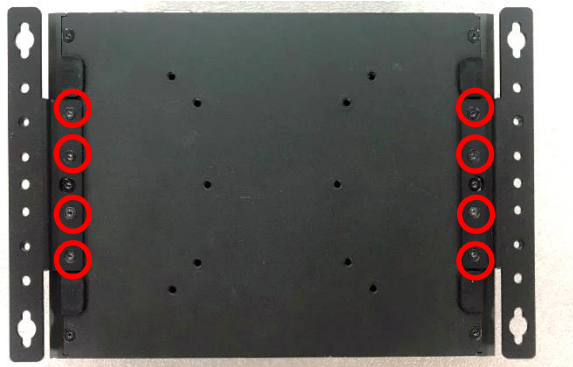

Step 2. Then user can fix the system onto the wall by fastening 2 mounting holes on each side of the wall mount bracket on the wall.



3.18 Installing Side Mount Kit

GM-1100 series offers Side Mount Kit (Model No.: SIDE-GM, 1 bracket and 8 screws) that customer can install system to the right or left side of wall to create effective of space.

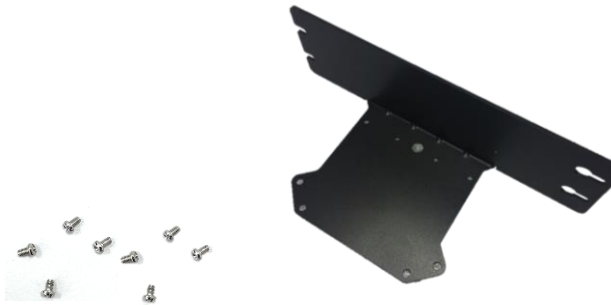

Step 1. The mounting holes are at the bottom side of system. Fasten the 8 screws (M3x5L*4pcs, M4x5L*4pcs) as indicated below to fix the side mount bracket with system together.

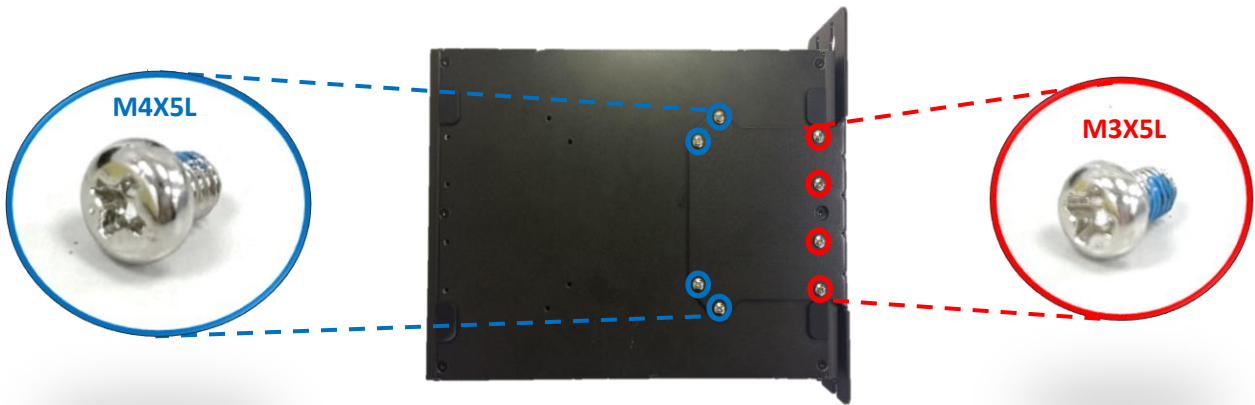

Step 2. Then it is feasible to secure the system to the wall by fastening the screws through the bracket mounting holes as indicated afterward.



3.19 Installing VESA Mount Accessories

The picture below shows the VESA mounting holes on the GM-1100 series, which comply with the VESA mounting standard. The blue holes correspond to the 75x75mm VESA mounting standard, and the red holes correspond to the 100x100mm VESA mounting standard. Users can use this system with VESA accessories of the corresponding sizes. In this section, we use a VESA stand as an example for installation.

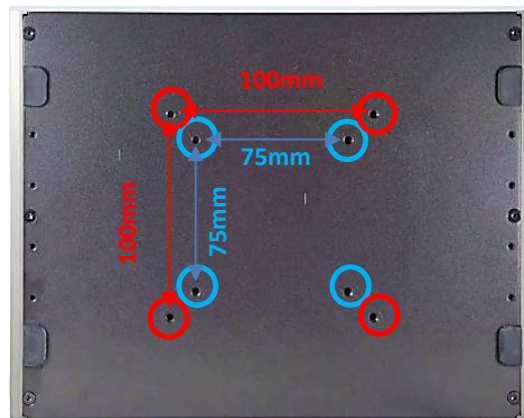

Step 1. Align the VESA stand with the screw holes on the system, then secure it in place by tightening the corresponding number of screws as shown below. (Please note the VESA mounting holes deep 3 mm at the back of the terminal are provided with 4 x M4-type blind fasteners to fix the VESA mounting plate. Please select a suitable screw length (L) based on the on-site application.) After completing this step, the VESA mount installation for the system is complete.

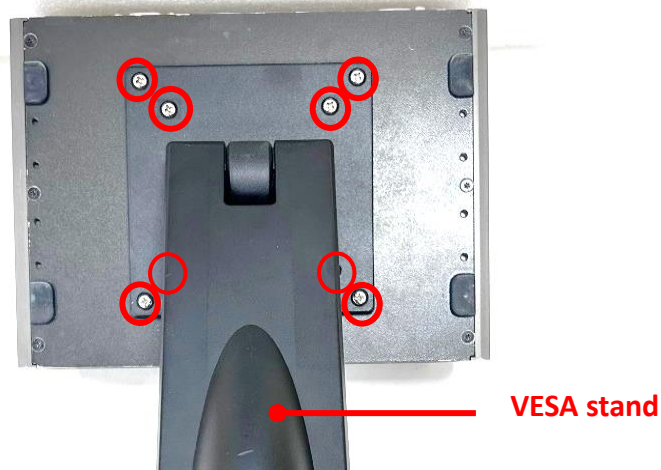

3.20 Installing DIN-Rail Mount Kit

GM-1100 series offers DIN-Rail Mount Kit (Model No.: DIN01, 2 clips and 4 screws) that customer can install system on the DIN Rail.

Step 1. Please refer to section 3.17 Wall Mount Brackets to install mounting bracket at both sides of system. Then fasten 2 DIN rail mounting clips to mounting brackets on both sides with provided 4 screws (with each screw size of T3x10.5) as illustrated below.



Step 2. Clip the system into DIN rail as illustrated by the following steps. (1) Have lower end of mounting clip snaps into the DIN rail. (2) Press the system toward to have upper end of mounting clip snaps into the other side of DIN rail.

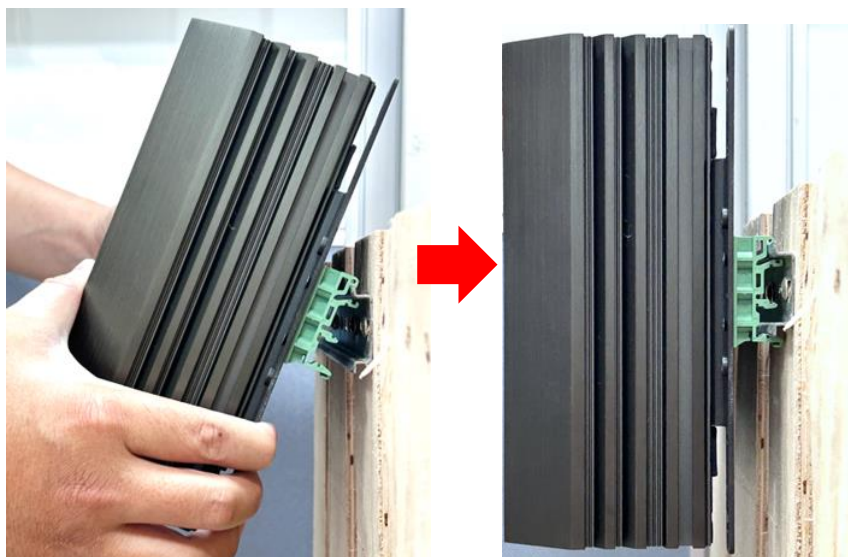

3.21 Installing External FAN

The GM-1100 series offers an optional accessory of the External FAN (Model No.: FAN-EX102) as shown in step 1. If you have acquired this accessory, please refer to the installation instructions hereafter.

Step 1. Locate the two screws on the mounting frame.

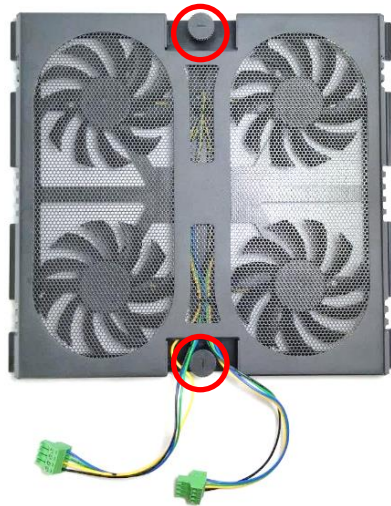

Step 2. Loosen two screws without removing them.



Step 3: Align the two screws and slide the fan into the middle groove of the chassis until it reaches the center position (the both screws will be in the groove at the same time).

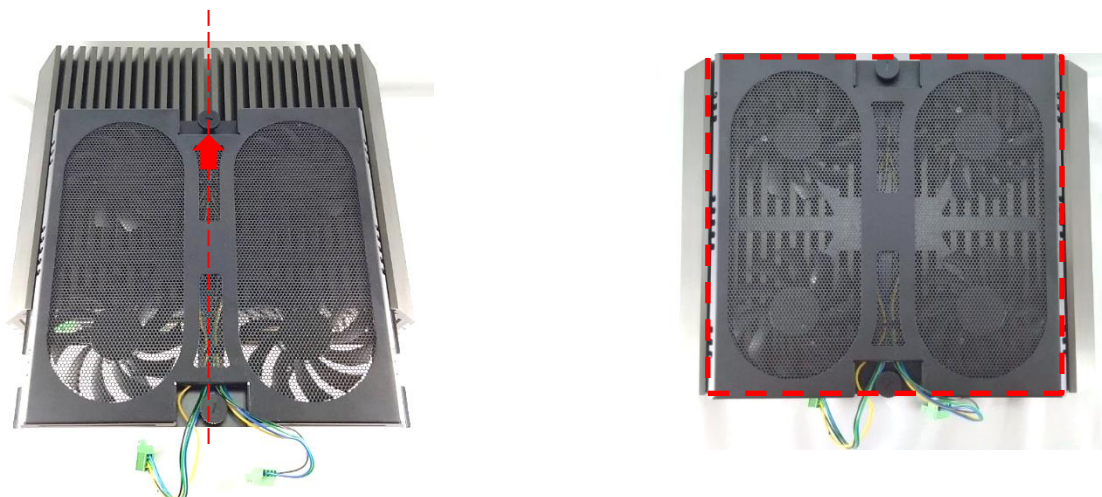

Step 4. Tighten the two screws.

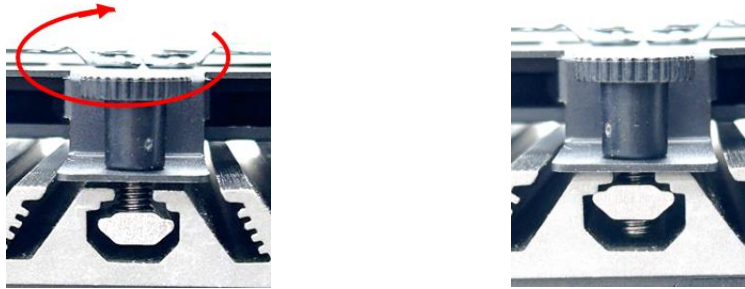

Step 5. Locate the two external fan power connectors.

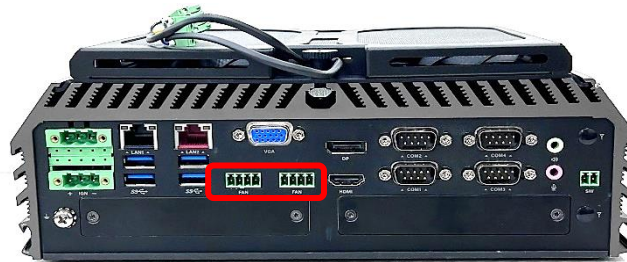



Step 6. Connect the FAN cables to the external fan power connectors firmly on the rear panel of the system in the way as indicated below.

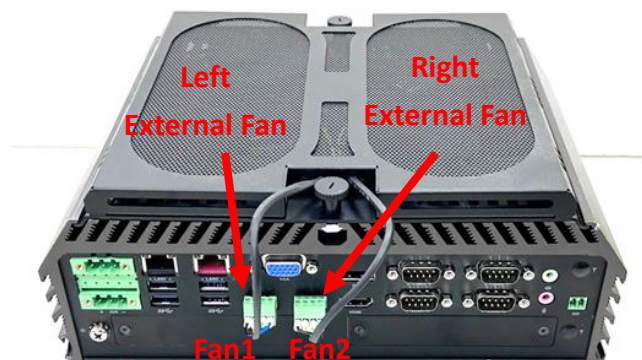

Step 7. Ensure the left external fan is connected to the FAN1: CPU smart fan connector, and the right external fan is connected to the FAN2: GPU (MXM) smart fan connector. For pin-out details, please refer to FAN1 and FAN2 in Chapter 2.4.





Chapter 4

BIOS Setup

4.1 BIOS Introduction

The BIOS (Basic Input/ Output System) is a program located on a Flash Memory on the motherboard. When you start the computer, the BIOS program will gain control. The BIOS first operates an auto-diagnostic test called POST (power on self-test) for all the necessary hardware, it detects the entire hardware device and configures the parameters of the hardware synchronization.

BIOS Setup

Power on the computer and by pressing immediately allows you to enter Setup. If the message disappears before your respond and you still wish to enter Setup, restart the system to try again by turning it OFF then ON or pressing <Ctrl>, <Alt> and <Delete> keys.

Control Keys	
<<> <>>	Move to select screen
<↑> <↓>	Move to select item
<Esc>	Quit the BIOS Setup
<Enter>	Select item
<Page Up/+>	Increases the numeric value or makes changes
<Page Down/->	Decreases the numeric value or makes changes
<Tab>	Select setup fields
<F1>	General help
<F2>	Previous value
<F3>	Load Optimized defaults
<F10>	Save configuration and Exit

Main Menu

The main menu lists the setup functions you can make changes to. You can use the arrow keys (↑ ↓) to select the item. The on-line description of the highlighted setup function is displayed at the bottom of the screen.

Sub-Menu

If you find a right pointer symbol appears to the left of certain fields that means a sub-menu can be launched from this field. A sub-menu contains additional options for a field parameter. You can use arrow keys (↑ ↓) to highlight the field and press <Enter> to call up the sub-menu. Then you can use the control keys to enter values and move from field to field within a sub-menu. If you want to return to the main menu, just press the <Esc >.

4.2 Main Setup

Press to enter BIOS CMOS Setup Utility, the Main Menu (as shown below) will appear on the screen. Use arrow keys to move among the items and press <Enter> to accept or enter a sub-menu.



■ System Date

Set the date. Please use <Tab> to switch between date elements.

■ System Time

Set the time. Please use <Tab> to switch between time elements.

4.3 Advanced Setup

This section allows you to configure and improve your system and allows you to set up some system features according to your preference.

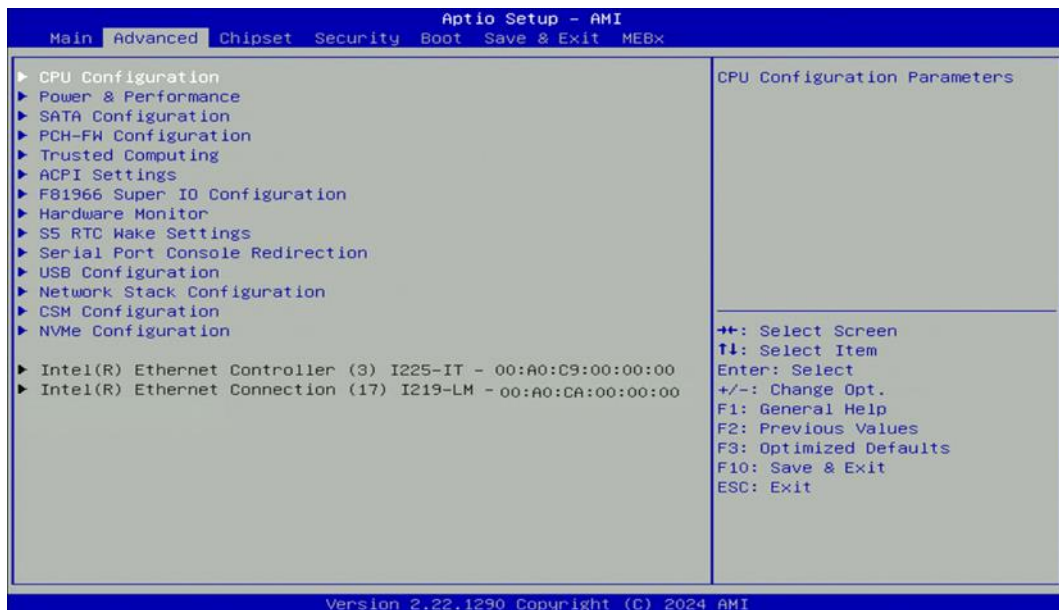

4.3.1 CPU Configuration



■ Efficient-core Information

This page displays the E-core Information.

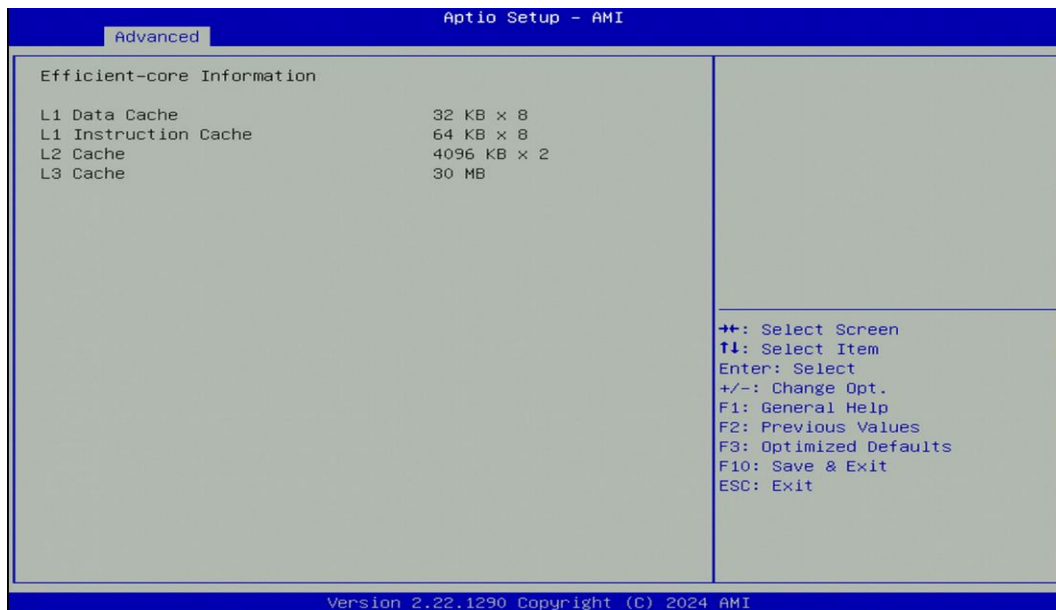

■ Performance-core Information

This page displays the P-core Information.



■ Intel (VMX) Virtualization Technology [Enabled]

Enables or disables Intel Virtualization Technology. Virtualization enhanced by Intel Virtualization Technology will allow a platform to run multiple operating systems and applications in independent partitions. With virtualization, one computer system can function as multiple virtual systems.

■ Active Performance-cores

Allows you to choose the number of active performance cores.

Configuration options: [All] [7] [6] [5] [4] [3] [2] [1].

■ Active Efficient-cores

Allows you to choose the number of active efficient cores.

Configuration options: [All] [7] [6] [5] [4] [3] [2] [1] [0].

■ Hyper-threading

Enables or disables for Hyper-Threading Technology.

4.3.2 Power & Performance



■ SKU Power Config [Auto]

Allows users to choose the upper limit of CPU power.

Configuration options: [Auto] [35W]

4.3.3 SATA Configuration



■ SATA Controller(s) [Enabled]

Enables or disables SATA device.

■ SATA Mode Selection [AHCI]

Allows you to select which mode SATA controller will operate.

Configuration options: [AHCI]

- **SATA 1**
Port [Enabled]
Enables or disables SATA 1.
- **SATA 2**
Port [Enabled]
Enables or disables SATA 2.
- **CN12**
Port [Enabled]
Enables or disables CN12.
- **CN13**
Port [Enabled]
Enables or disables CN13.
- **CN14**
Port [Enabled]
Enables or disables CN14.
- **CN15**
Port [Enabled]
Enables or disables CN15.

4.3.4 PCH-FW Configuration

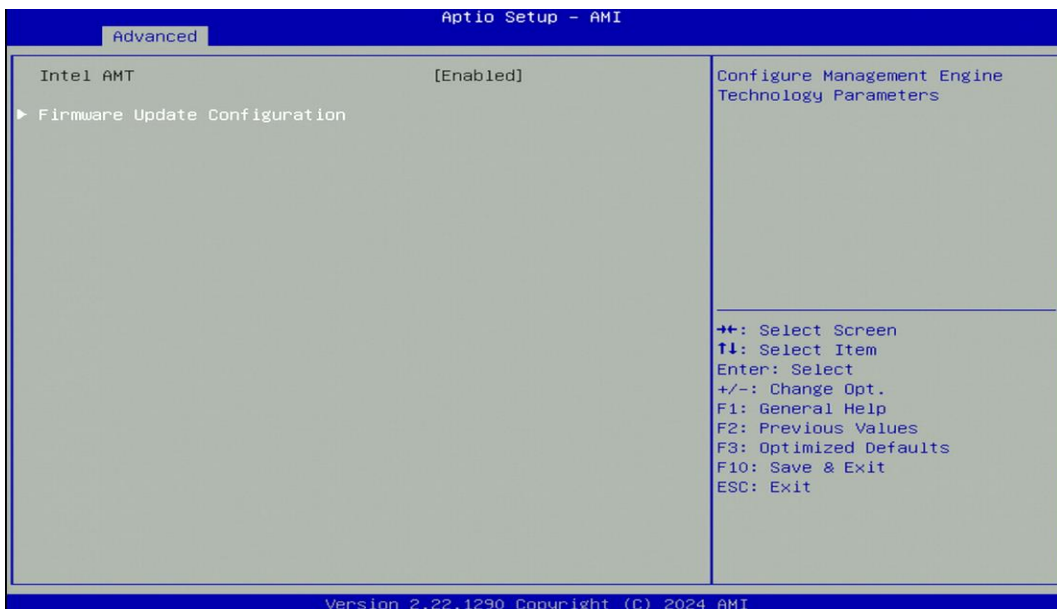

■ Firmware Update Configuration

Configure Management Engine Parameters

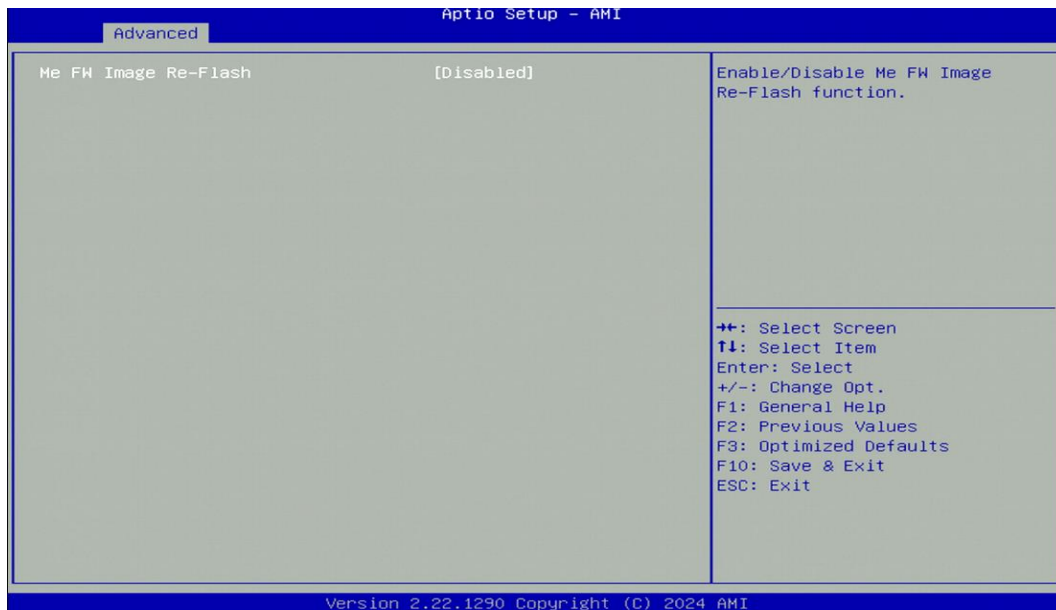

■ **Me FW Image Re-Flash [Disabled]**

Enables or disables ME firmware Image Re-Flash function.

4.3.5 Trusted Computing Settings

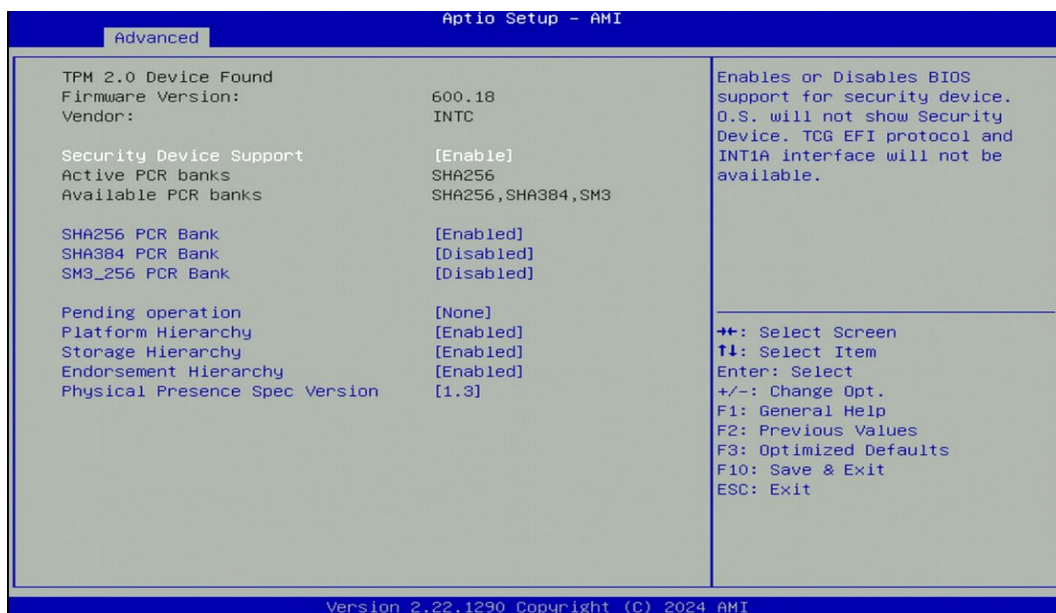

■ **Security Device Support [Enabled]**

Enables or disables Security Device Support function.

■ **SHA256 PCR Bank [Enabled]**

Enables or disables SHA256 PCR Bank function.

■ **SHA384 PCR Bank [Disabled]**

Enables or disables SHA384 PCR Bank function.

■ **SM3_256 PCR Bank [Disabled]**

Enables or disables SM3_256 PCR Bank function.

■ Pending Operation [None]

Allows you to select which mode Pending Operation will operate.

Configuration options: [None], [TPM Clear]

■ Platform Hierarchy [Enabled]

Enables or disables Platform Hierarchy function.

■ Storage Hierarchy [Enabled]

Enables or disables Storage Hierarchy function.

■ Endorsement Hierarchy [Enabled]

Enables or disables Endorsement Hierarchy function.

■ Physical Presence Spec Version [1.3]

Allows you to select which mode Physical Presence Spec Version will operate.

Configuration options: [1.2], [1.3]

4.3.6 ACPI Settings



■ Enable Hibernation [Enabled]

Enables or disables system ability to hibernate state (OS/S4 state). This option may not be effective with some OS.

■ ACPI Sleep State [S3 (Suspend to RAM)]

Allows users to select the highest Advanced Configuration Power Interface® (ACPI) sleep state that system will enter when suspend button is pressed.

[Suspend Disabled]: Disables entering suspend state.

[S3 (suspend to RAM)]: Enables suspend to RAM state.

4.3.7 F81966 Super IO Configuration

Set Parameters of Serial Ports. User can Enable/Disable the serial port and select an optimal setting for the Super IO Device.

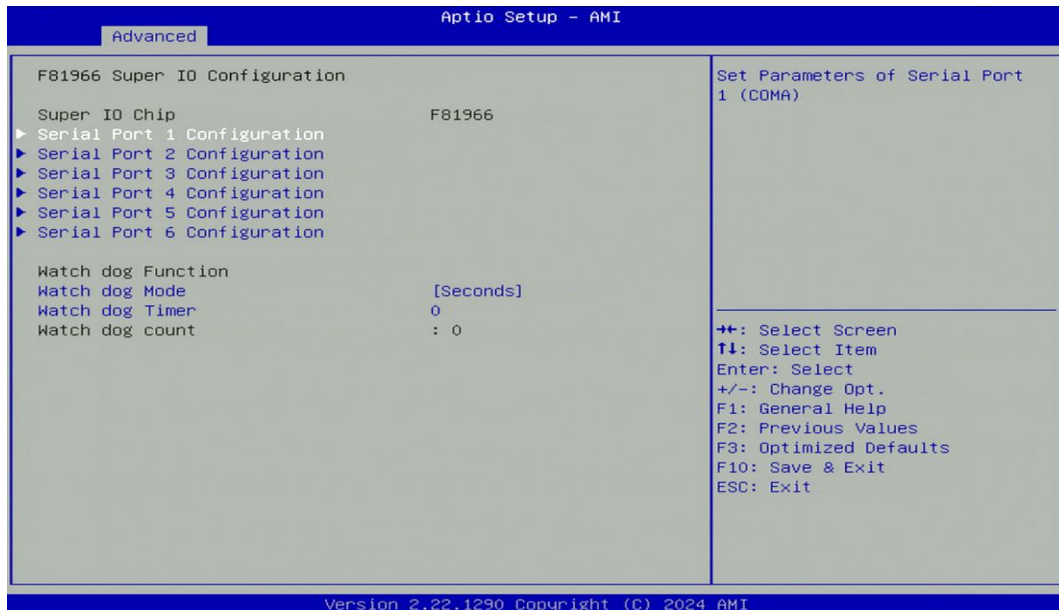

■ Serial Port 1 Configuration.

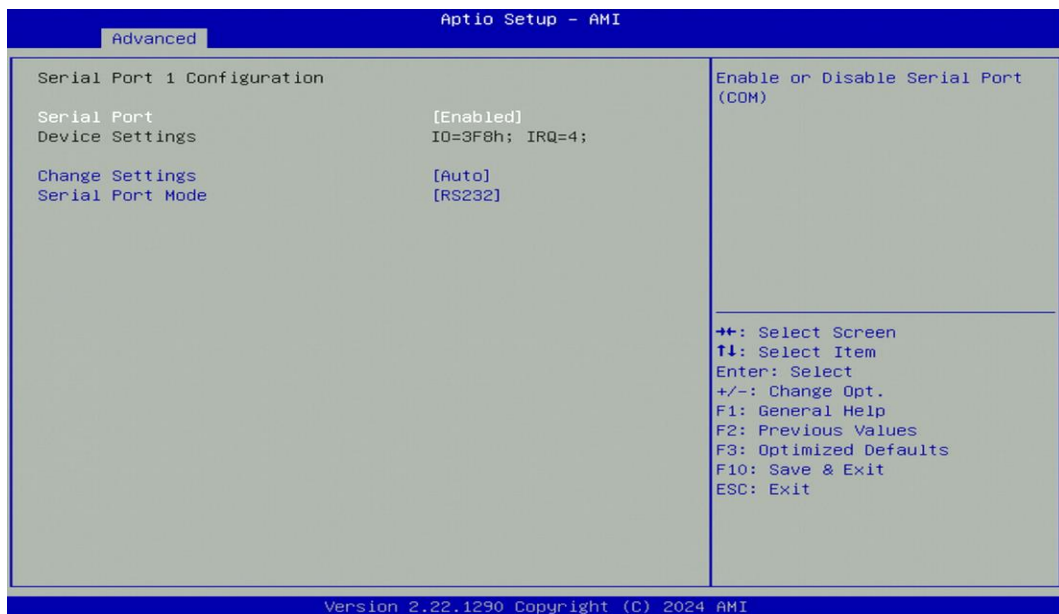

■ Serial Port [Enabled]

Enables or disables serial port.

■ Change Settings [Auto]

Allows you to change the IO Address & IRQ settings of the specified serial port.

■ Onboard Serial Port 1~2 Mode [RS232]

Allows you to select Serial Port Mode.

Configuration options: [RS232] [RS422/RS485 Full Duplex] [RS485 Half Duplex]

■ Watch Dog [Disabled]

Enables or disables watch dog function.

■ Watch Dog Mode [Sec]

Allows to set watchdog timer unit <Sec> or <Min>.

■ Watch Dog Timer [0]

Allows you to set watchdog timer's value in the range of 0 to 255.

4.3.8 Hardware Monitor

This screen displays the current status of all monitored hardware devices/components such as voltages, temperatures.

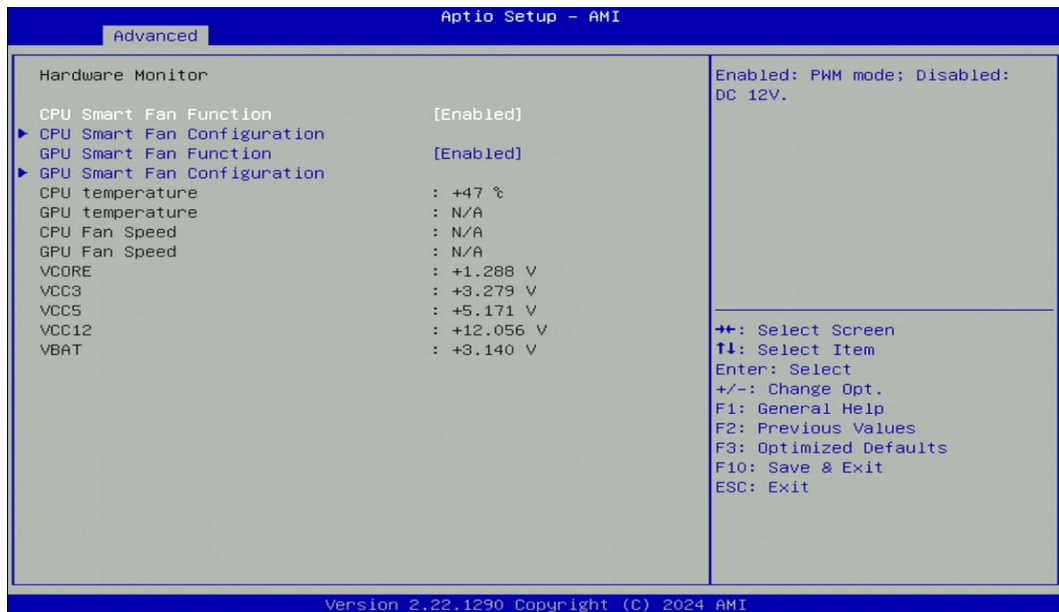

■ CPU Smart Fan Function [Enabled]

Enables or disables CPU Smart Fan function.

■ CPU Smart Fan Configuration

Allows users to setting CPU smart fan parameters.

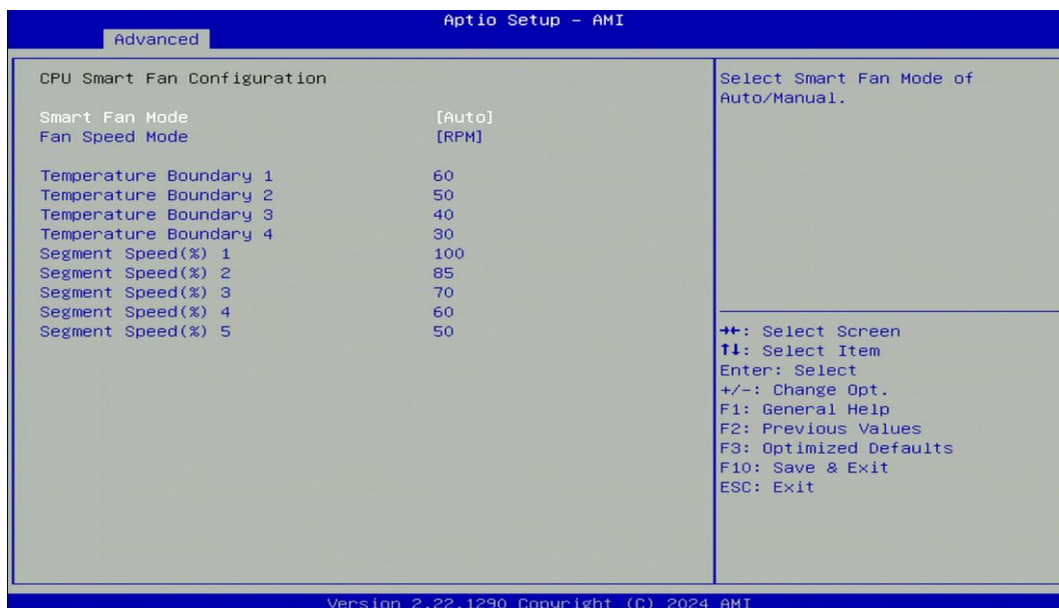

■ Smart Fan Mode [Auto]

Allows you to select Smart Fan Mode.

Configuration options: [Auto] [Manual]

■ Fan Speed Mode [RPM]

Allows you to select Fan Speed Mode.

Configuration options: [RPM] [Duty]

■ GPU Smart Fan Function [Enabled]

Enables or disables GPU Smart Fan function.

■ GPU Smart Fan Configuration

Allows users to setting GPU smart fan parameters.

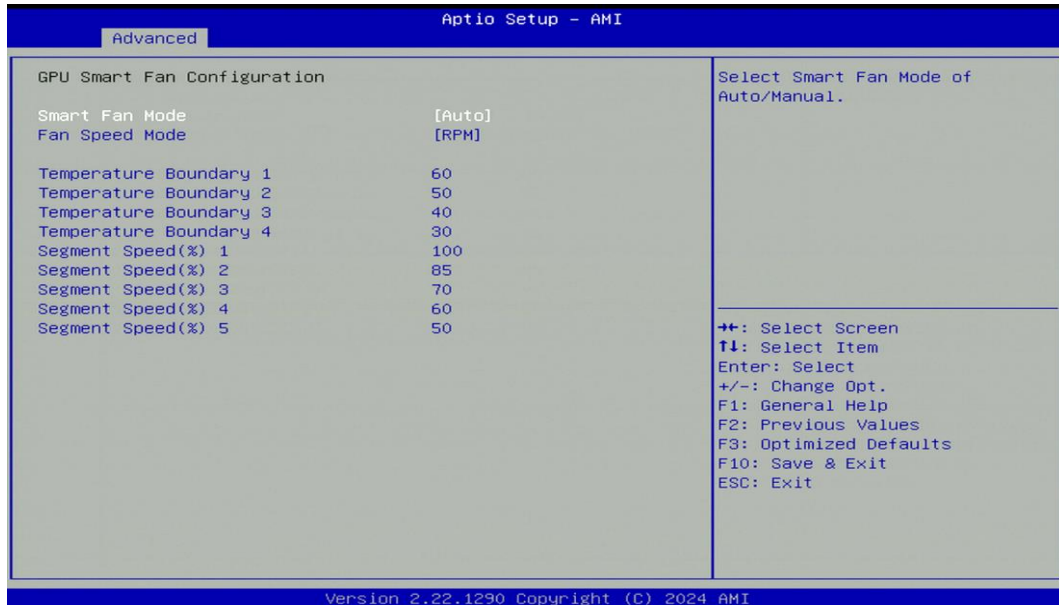

■ Smart Fan Mode [Auto]

Allows you to select Smart Fan Mode.

Configuration options: [Auto] [Manual]

■ Fan Speed Mode [RPM]

Allows you to select Fan Speed Mode.

Configuration options: [RPM] [Duty]

4.3.9 S5 RTC Wake Settings

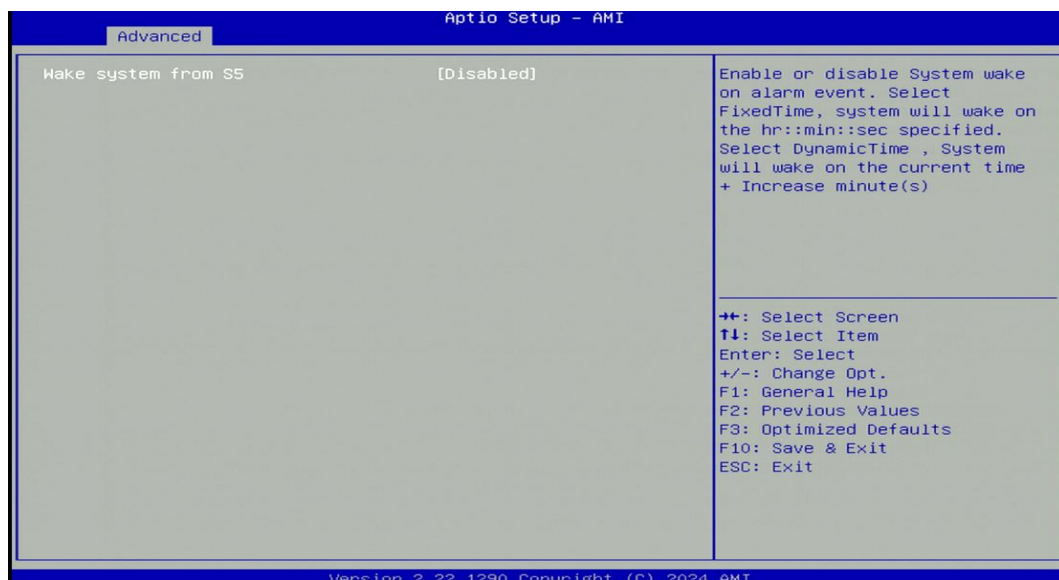

■ Wake system from S5 [Disabled]

Enables or disables wake system from S5 (soft-off state).

[Disabled]: Disables wake system from S5.

[Fixed Time]: Sets a fixed time (HH:MM:SS) to wake system from S5.

[Dynamic Time]: Sets an increase minute(s) from current time to wake system from S5.

4.3.10 Serial Port Console Redirection

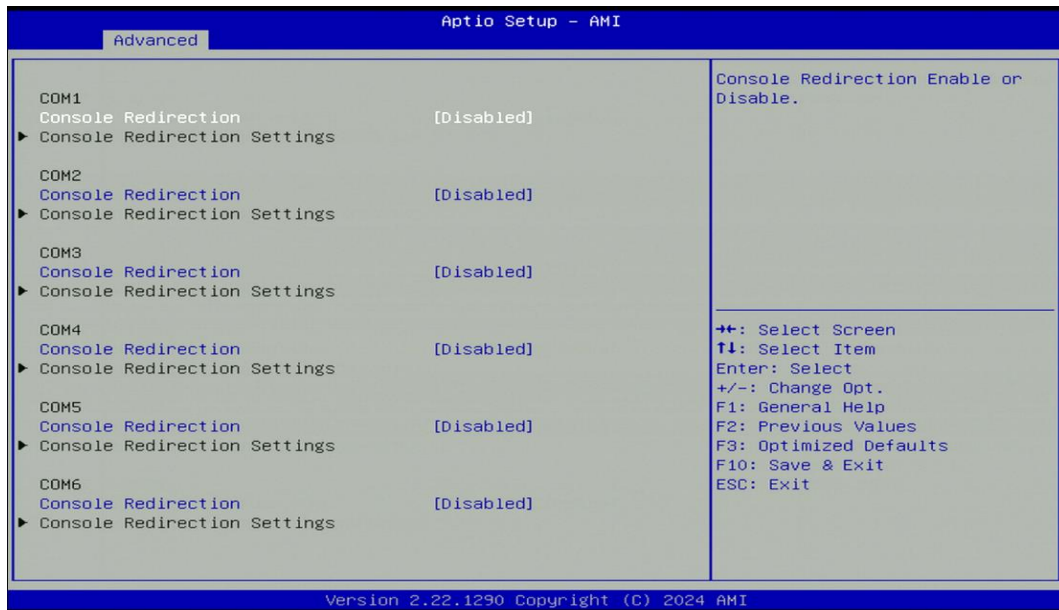

■ Console Redirection [Disabled]

Allow users to enable or disable COM1, COM2 console redirection function.

4.3.11 USB Configuration



■ **XHCI Hand-off [Enabled]**

Enables or disables XHCI (USB3.0) hand-off function. Use this feature as a workaround for operating systems without XHCI hand-off support.

■ **USB Mass Storage Driver Support [Enabled]**

Enables or disables USB mass storage driver support.

4.3.12 Network Stack Configuration

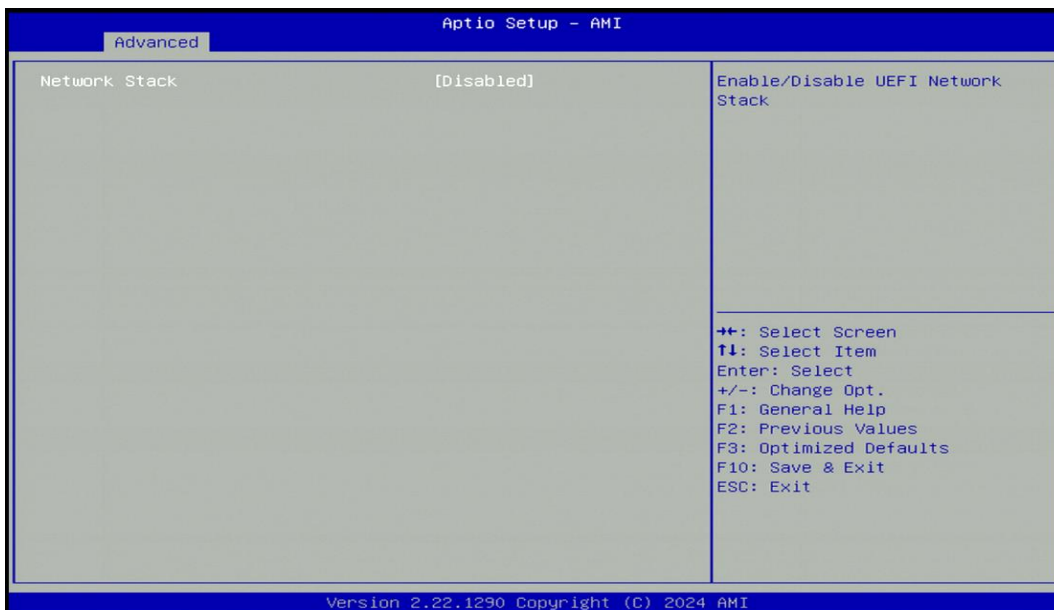

■ **Network Stack [Disabled]**

Enables or disables UEFI Network Stack.

4.3.13 CSM Configuration

This option controls legacy/UEFI ROMs priority.

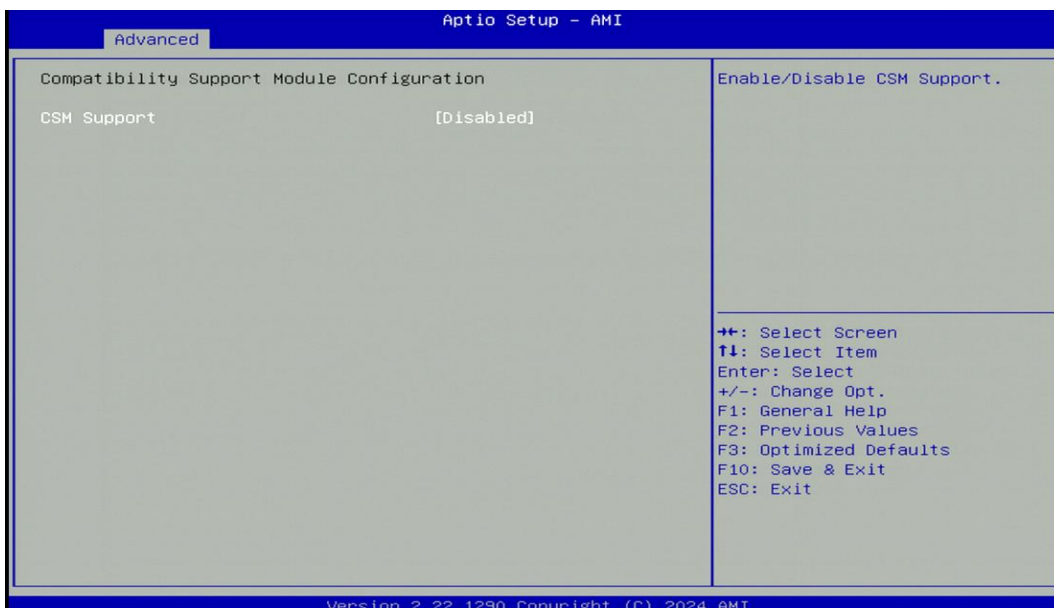

■ CSM Support [Disabled]

Enables or disables compatibility support module.

4.3.14 NVMe Configuration

The screen allows users to select options for the NVMe configuration, and change the value of the selected option. If there is NVMe Device detected, the options will show as the NVMe Device is found.

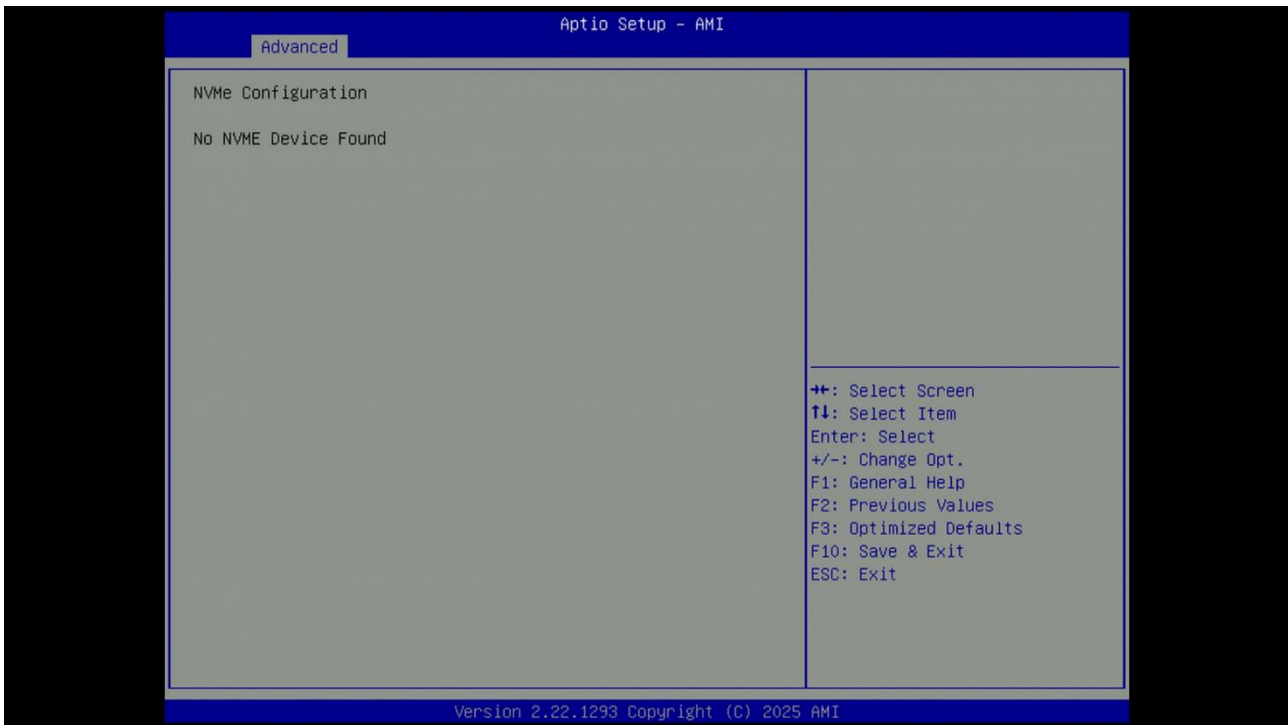

4.4 Security Setup

This section allows users to configure BIOS security settings.

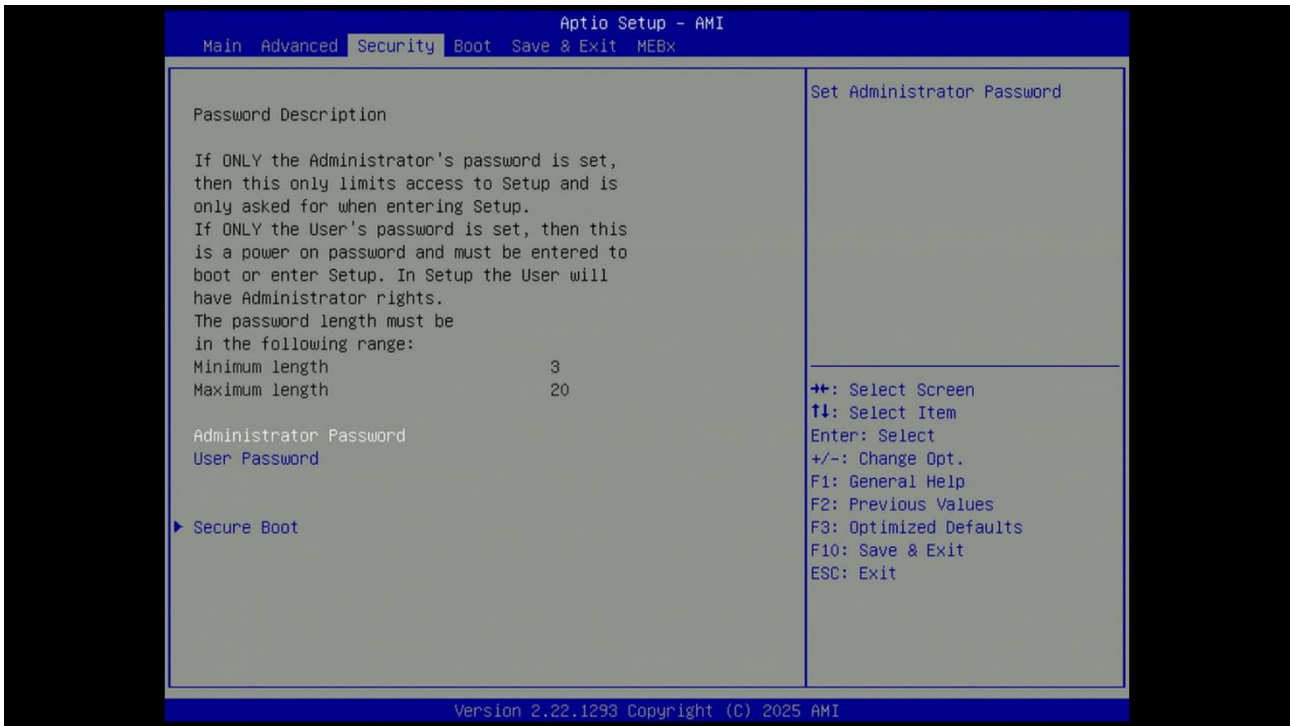

■ **Administrator Password**

Administrator Password controls access to the BIOS Setup utility.

■ **User Password**

User Password controls access to the system at boot and to the BIOS Setup utility.

■ **Security Boot**



- **Secure Boot [Disabled]**
Enable or disable Secure Boot function.
- **Secure Boot Mode [Standard]**
Allows you to select Secure Boot Mode.
Configuration options: [Standard] [Custom].

4.5 Boot Setup

This section allows you to configure Boot settings.



- **Setup Prompt Timeout [1]**

Use this item to set number of seconds (1..65535) to wait for setup activation key.

- **Bootup NumLock State [Off]**

Allows you to set NumLock key to [On] or [Off] state when system boots up.

- **Quiet Boot [Disabled]**

Allows you to enable or disable Quiet Boot function.

- **Fast Boot [Disabled]**

Allows you to enable or disable Fast Boot function. If enabled, system boots with initialization of a minimal set of devices required to launch active boot option.

4.6 Save & Exit

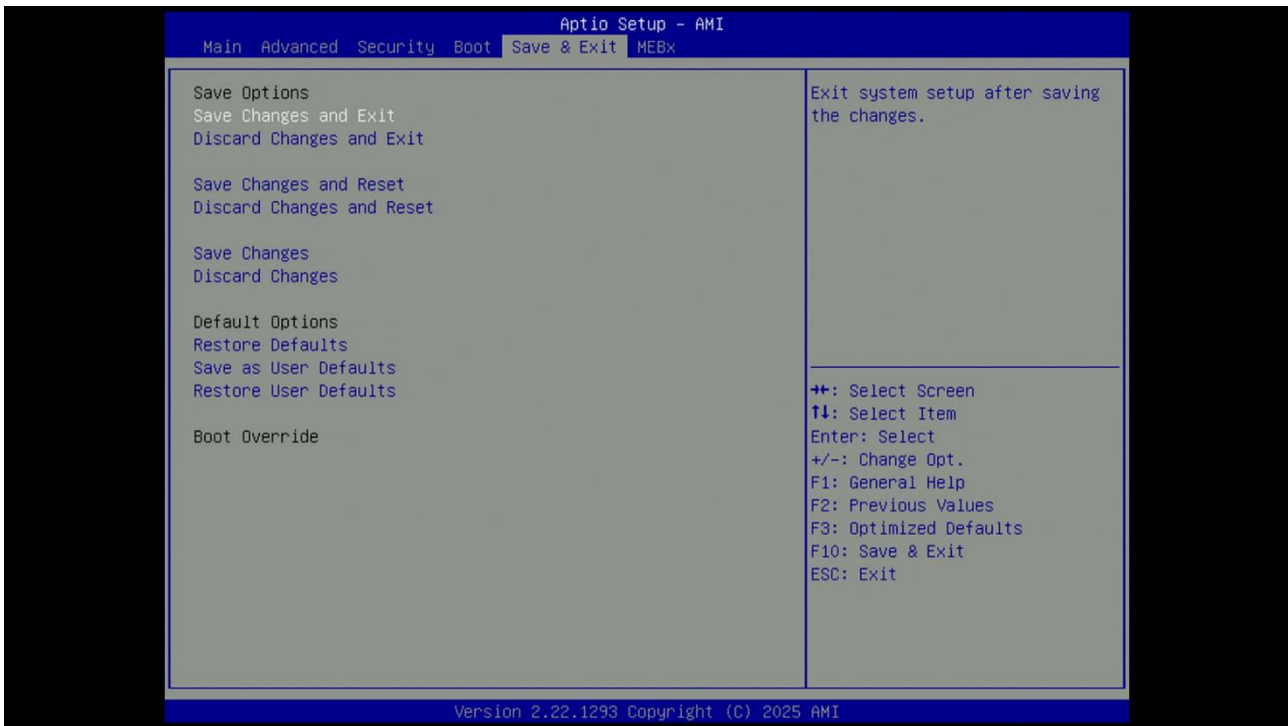

■ Save Changes and Exit

This item allows you to exit the system after saving changes.

■ Discard Changes and Exit

This item allows you to exit system setup without saving any changes.

■ Save Changes and Reset

This item allows you to reset the system after saving changes.

■ Discard Changes and Reset

This item allows you to reset system setup without saving any changes.

■ Save Changes

This item allows you to save changes.

■ Discard Changes

This item allows you to discard changes.

■ Restore Defaults

This item allows you to restore/ load default values for all the setup options.

■ Save as User Defaults

This item allows you to save the changes done so far as user defaults.

■ Restore User Defaults

This item allows you to restore the user defaults to all the setup options.

4.8 MEBx

This page is dedicated to configuring the ME function. After the system powers on, press the delete key promptly to access the BIOS menu, allowing users to view the following MEBx page.



Press enter key to enter the default password "admin" to enter the next step for password creation.

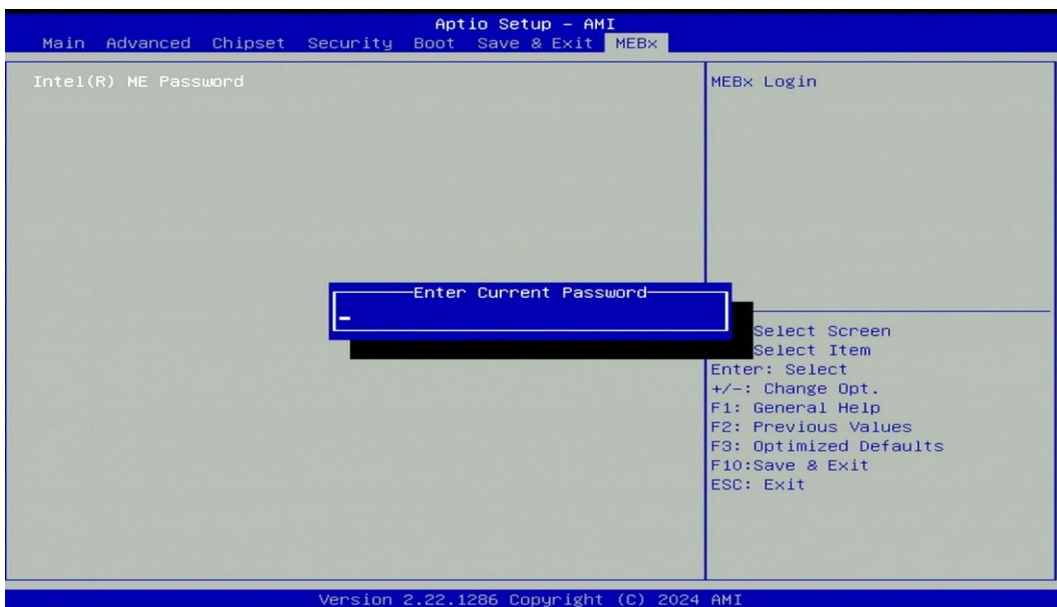

Create a new password using 8 characters including uppercase and lowercase letters, numbers and special symbols. (For example, "Abc123!!")

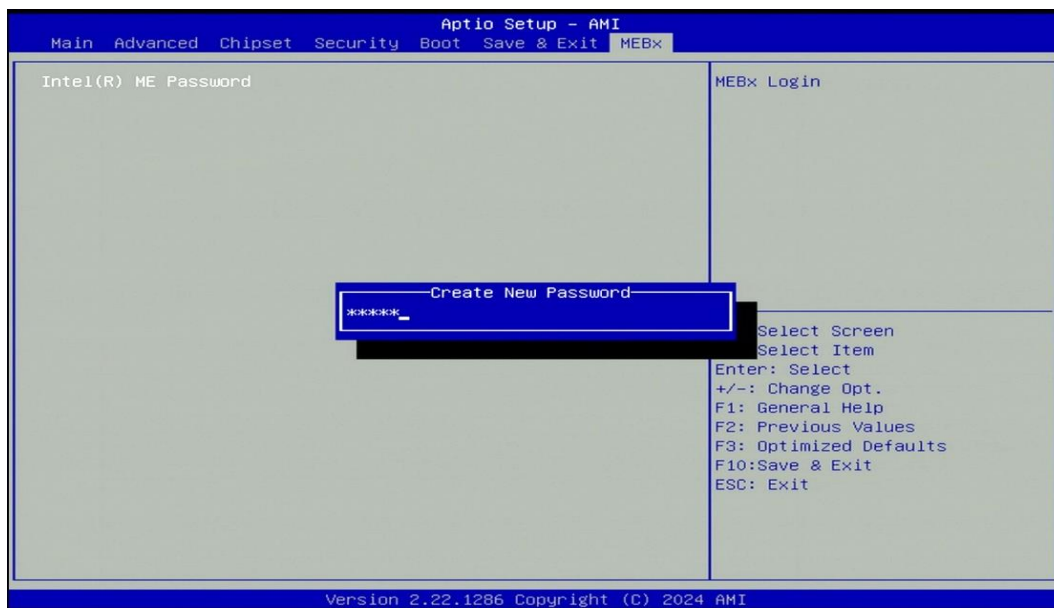

Enter the created password again for confirmation.

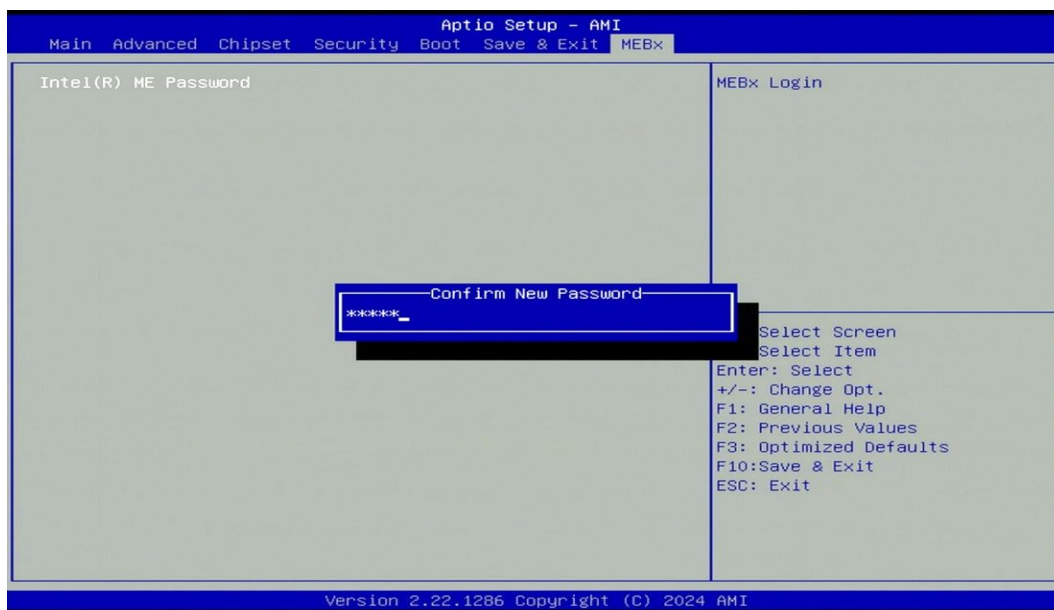

Afterward, you will be directed to the MEBx function setting page."

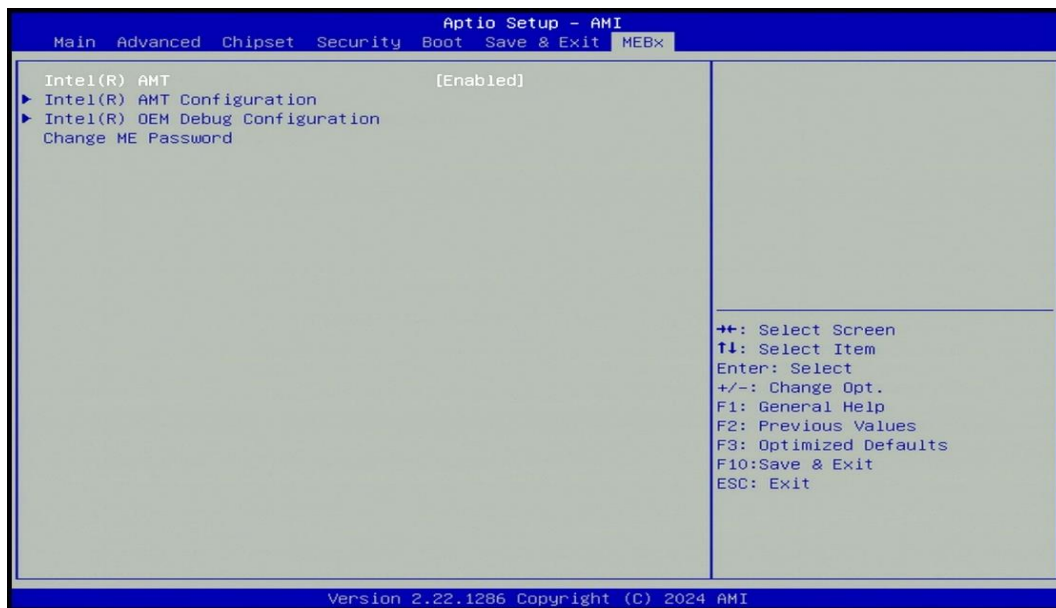



Chapter 5

Product Application

5.1 Where to download drivers?

Drivers for the GM-1100 Series can be downloaded from the CINCOZE website.

5.2 Where to find the technical documents?

The following documents are the most relevant technical references for the GM-1100 Series. All documents can be accessed via the CINCOZE Partner Zone:

- **Application Notes:** Navigate to *Home > Partner Zone > Technical Support > Application Notes*.
- **Configure & Installation:** Navigate to *Home > Partner Zone > Technical Support > Configure & Installation*.
- **Other Product Information:** Navigate to *Home > Partner Zone > Product Center > Product Information > GPU Embedded Computers > Embedded MXM GPU Computer > GM-1100 Series*.

Catalog	Document Title
Application Notes	DIO Application Guide
	DIO Technical Guide
	Instant Reboot Application Guide
	WDT Application Guide
	WDT Technical Guide
Configure & Installation	AT ATX Power Mode Function Manual
	BIOS Administrator User Password
	Clear CMOS Function Manual
	COM Port Function Manual
	CSM Function Manual
	Digital I/O Function Manual
	How to import Secure Boot Key?
	How to restore Windows image with Clonezilla?
	How to set TPM function under Windows?
	How to stop automatic driver update in Windows
	How to Update BIOS and ME under UEFI shell?
	How to Update BIOS under UEFI shell?
	How to Update BIOS under Windows?
	IGN Module User Manual
	Intel AMT with KVM Remote Control
	PoE Module User Manual
	PXE Function Manual
RAID Function Manual	
Remote Switch Function Manual	

	Wake On LAN Function Manual
	WDT Function Manual

cincoze

© 2024 Cincoze Co., Ltd. All rights reserved.

The Cincoze logo is a registered trademark of Cincoze Co., Ltd.

All other logos appearing in this catalog are the intellectual property of the respective company, product, or organization associated with the logo.

All product specifications and information are subject to change without notice.