

cicoze

DX-1300

User Manual



Rugged Embedded Computer

Intel® Arrow Lake-S Core™ Ultra 200S Series Processors, High Performance and Compact Rugged Embedded Computer

Contents

Preface	5
Revision	5
Copyright Notice	5
Acknowledgement	5
Disclaimer.....	5
Declaration of Conformity.....	6
Product Warranty Statement	6
Technical Support and Assistance	7
Conventions Used in this Manual	8
Safety Precautions.....	8
Package Contents	9
Ordering Information	10
Chapter 1 Product Introductions	11
1.1 Overview	12
1.2 Specifications	14
1.3 External Layout.....	18
1.3.1 Front.....	18
1.3.2 Rear	18
1.4 Dimensions.....	19
Chapter 2 Switches & Connectors.....	20
2.1 Location of Switches and Connectors	21
2.1.1 Top View	21
2.1.2 Bottom View	21
2.2 Switches and Connectors Definition	22
2.3 Definition of Switches	23
2.4 Definition of Connectors	25
2.5 Optional Modules: Definition of Switches and Connectors.....	31
2.5.1 CMI-M12LAN01-R12/ UB1710-R10	31
2.5.2 CMI-XM12LAN01-R10/ UB0930-R10	31
2.5.3 CMI-2P5GLAN01-R10/UB1712.....	31
2.5.4 CMI-10GXM12LAN01-R10/UB1737	32
2.5.5 CMI-COM01/UB1303	33
2.5.6 CFM-IGN01.....	34
2.5.7 CMI-DIO01.....	35
Chapter 3 System Setup	36
3.1 Removing Top Cover	37
3.2 Installing CPU	39
3.3 Installing SO-DIMM Memory	44
3.4 Installing M.2 Key B Module	45

3.4.1	CN7 (M.2 Key B Type 3052/ 3042/ 2242).....	45
3.4.2	CN6 (M.2 Key B type 2242)	47
3.5	Installing M.2 Key E Module.....	48
3.6	Installing Antenna(s)	49
3.6.1	Antennas 1 and 2	49
3.6.2	Antenna 3.....	51
3.7	Installing Antenna Cutout Universal Bracket	53
3.8	Installing Covers	54
3.9	Installing SATA HDD/SSD	56
3.10	Installing SIM Card	59
3.11	Replacing CMOS Battery	60
3.12	Installing Wall Mount	62
3.13	Installing VESA Mount.....	63
3.14	Installing CMI Modules	64
3.14.1	CMI-10GLAN05-R10/UB1728-R10	64
3.14.2	CMI-LAN01-R12/UB1712-R10.....	68
3.14.3	CMI-M12LAN01-R12/UB1710-R10	70
3.14.4	CMI-XM12LAN01-R10/UB0930-R10	73
3.14.5	CMI-10GXM12LAN01-R10/UB1737-R10.....	76
3.14.6	CMI-2P5GLAN01-R10/UB1712-R10	80
3.14.7	CMI-COM01/UB1303	84
3.14.8	CMI-DIO01/UB1318	85
3.15	Installing CFM Modules.....	87
3.15.1	CFM-PoE01.....	87
3.15.2	CFM-IGN01.....	89
3.15.3	CFM-TPM02	90
3.16	SIDE-DX.....	92
3.17	DIN01	93
3.18	FAN-EX101.....	94
Chapter 4	BIOS Setup.....	96
4.1	BIOS Introduction.....	97
4.2	Main Setup.....	98
4.3	Advanced Setup	99
4.3.1	CPU Configuration.....	99
4.3.2	Power & Performance	100
4.3.3	System Agent (SA) Configuration	101
4.3.4	PCIE Configuration	104
4.3.5	PCH-IO Configuration	105
4.3.6	PCH-FW Configuration	107
4.3.7	Trusted Computing.....	108
4.3.8	ACPI Settings	109

4.3.9	F81966 Super IO Configuration.....	110
4.3.10	Hardware Monitor	111
4.3.11	S5 RTC Wake Settings	112
4.3.12	Serial Port Console Redirection.....	112
4.3.13	USB Configuration	113
4.3.14	Network Stack Configuration	113
4.3.15	NVMe Configuration	114
4.4	Security Setup	114
4.5	Boot Setup.....	116
4.6	Save & Exit.....	117
4.7	MEBx	118
Chapter 5 Product Application		121
5.1	Where can I download drivers?	122
5.2	Where can I find technical documents?	122

Declaration of Conformity



FCC

This equipment has been tested and found to comply with the limits for a Class A digital device, pursuant to Part 15 of the FCC Rules. These limits are designed to provide reasonable protection against harmful interference when the equipment is operated in a commercial environment. This equipment generates, uses, and can radiate radio frequency energy and, if not installed and used in accordance with the instruction manual, may cause harmful interference to radio communications. Operation of this equipment in a residential area is likely to cause harmful interference in which case the user will be required to correct the interference at his own expense.



CE

The product(s) described in this manual complies with all application European Union (CE) directives if it has a CE marking. For computer systems to remain CE compliant, only CE-compliant parts may be used. Maintaining CE compliance also requires proper cable and cabling techniques.



UL

A product that carries the “UL Listed” approval mark means that the product has been tested by UL to nationally recognized Safety Standards and has been found to be free from reasonably foreseeable risk of fire, electric shock and related hazards.

Product Warranty Statement

Warranty

Cincoze products are warranted by Cincoze Co., Ltd. to be free from defect in materials and workmanship for 2 years from the date of purchase by the original purchaser. During the warranty period, we shall, at our option, either repair or replace any product that proves to be defective under normal operation. Defects, malfunctions, or failures of the warranted product caused by damage resulting from natural disasters (such as by lightning, flood, earthquake, etc.), environmental and atmospheric disturbances, other external forces such as power line disturbances, plugging the board in under power, or incorrect cabling, and damage caused by misuse, abuse, and unauthorized alteration or repair, and the product in question is either software, or an expendable item (such as a fuse, battery, etc.), are not warranted.

RMA

Before sending your product in, you will need to fill in Cincoze RMA Request Form and obtain an RMA number from us. Our staff is available at any time to provide you with the most friendly and immediate service.

■ RMA Instruction

- Customers must fill in the Cincoze Return Merchandise Authorization (RMA) Request Form and obtain an RMA number prior to returning a defective product to Cincoze for service.
- Customers must collect all the information about the problems encountered and note anything abnormal, and describe the problems on the “Cincoze Service Form” for the RMA number application process.
- Charges may be incurred for certain repairs. Cincoze will charge for repairs to products whose warranty period has expired. Cincoze will also charge for repairs to products if the damage resulted from acts of God, environmental or atmospheric disturbances, or other external forces through misuse, abuse, or unauthorized alteration or repair. If charges will be incurred for a repair, Cincoze lists all charges and will wait for the customer’s approval before performing the repair.
- Customers agree to ensure the product or assume the risk of loss or damage during transit, to prepay shipping charges, and to use the original shipping container or equivalent.
- Customers can be sent back the faulty products with or without accessories (manuals, cables, etc.) and any components from the system. If the components were suspected as part of the problem, please note clearly which components are included. Otherwise, Cincoze is not responsible for the devices/parts.
- Repaired items will be shipped along with a "Repair Report" detailing the findings and actions taken.

Limitation of Liability

Cincoze’ liability arising out of the manufacture, sale, or supplying of the product and its use, whether based on warranty, contract, negligence, product liability, or otherwise, shall not exceed the original selling price of the product. The remedies provided herein are the customer’s sole and exclusive remedies. In no event shall Cincoze be liable for direct, indirect, special or consequential damages whether based on contract of any other legal theory.

Technical Support and Assistance

1. Visit the Cincoze website at www.cincoze.com where you can find the latest information about the product.
2. Contact your distributor or our technical support team, or sales representative for technical support if you need additional assistance. Please have the following information ready before you call:
 - Product name and serial number
 - Description of your peripheral attachments
 - Description of your software (operating system, version, application software, etc.)
 - A complete description of the problem
 - The exact wording of any error messages

Conventions Used in this Manual



WARNING
(AVERTIR)

This indication alerts operators to an operation that, if not strictly observed, may result in severe injury.

(Cette indication avertit les opérateurs d'une opération qui, si elle n'est pas strictement observée, peut entraîner des blessures graves.)



CAUTION
(ATTENTION)

This indication alerts operators to an operation that, if not strictly observed, may result in safety hazards to personnel or damage to equipment.

(Cette indication avertit les opérateurs d'une opération qui, si elle n'est pas strictement observée, peut entraîner des risques pour la sécurité du personnel ou des dommages à l'équipement.)



NOTE
(NOTE)

This indication provides additional information to complete a task easily.

(Cette indication fournit des informations supplémentaires pour effectuer facilement une tâche.)

Safety Precautions

Before installing and using this device, please note the following precautions.

1. Read these safety instructions carefully.
2. Keep this User's Manual for future reference.
3. Disconnect this equipment from any AC outlet before cleaning.
4. For plug-in equipment, the power outlet socket must be located near the equipment and must be easily accessible.
5. Keep this equipment away from humidity.
6. Put this equipment on a reliable surface during installation. Dropping it or letting it fall may cause damage.
7. Make sure the voltage of the power source is correct before connecting the equipment to the power outlet.
8. Use a power cord that has been approved for use with the product and that matches the voltage and current marked on the product's electrical range label. The voltage and current rating of the cord must be greater than the voltage and current rating marked on the product.
9. Position the power cord so that people cannot step on it. Do not place anything over the power cord.
10. All cautions and warnings on the equipment should be noted.
11. If the equipment is not used for a long time, disconnect it from the power source to avoid damage from transient overvoltage.
12. Never pour any liquid into an opening. This may cause fire or electrical shock.

13. Never open the equipment. For safety reasons, the equipment should be opened only by qualified service personnel.

If one of the following situations arises, get the equipment checked by service personnel:

- The power cord or plug is damaged.
- Liquid has penetrated into the equipment.
- The equipment has been exposed to moisture.
- The equipment does not work well, or you cannot get it to work according to the user's manual.
- The equipment has been dropped and damaged.
- The equipment has obvious signs of breakage.

14. CAUTION: Risk of Explosion if Battery is replaced by an Incorrect Type. Dispose of Used Batteries According to the Instructions.

ATTENTION: Risque d'explosion si la batterie est remplacée par un type incorrect. Mettre au rebut les batteries usagées selon les instructions.

15. Equipment intended only for use in a RESTRICTED ACCESS AREA.
16. Output of the external power source shall comply with ES1, PS3 requirements, output rating between 9-48 VDC, minimum 12.5-2.5A, with minimum rated maximum ambient temperature 60°C, and has to be evaluated according to UL/IEC/EN 60950-1 and/or UL/IEC/EN 62368-1. Please contact Cincoze for more information.
17. Ensure to connect the power cord of the power adapter to a socket-outlet with an earth connection.
18. Dispose of used battery promptly. Keep away from children. Do not disassemble and do not dispose of in fire.

Package Contents

Before installation, please ensure all items listed in the table below are included in the package.

Item	Description	Q'ty
1	DX-1300 Series Embedded System	1
2	CPU Heatsink Pack	1
3	Screw Pack	1
4	Wall Mounting Kit	1
5	Power Terminal Block Connector	1
6	Remote Power On/Off Terminal Block Connector	1
7	Fan Terminal Block Connector	1
8	M.2 Key B Type 3052 to 3042 Adapter Bracket	1

Note: Notify your sales representative if any of the above items are missing or damaged.

Ordering Information

Model No.	Description
DX-1300-R10	Intel® Arrow Lake-S Core™ Ultra 200S Series Processors, High Performance and Compact Rugged Embedded Computer



Chapter 1

Product Introductions

1.1 Overview

The DX-1300 is a compact industrial computer engineered for high-performance edge computing. Powered by an Intel Arrow Lake-S Core™ Ultra 200S series processor, it supports demanding edge applications, including advanced image processing, AI inference, and data integration across multiple tasks. The DX-1300 series packs exceptional computing performance and a rich feature set into a compact chassis while maintaining industrial-grade ruggedness. It is particularly well-suited for high-performance applications with limited installation space and has earned high acclaim in the manufacturing, in-vehicle, and railway markets.



Key Features

- Intel® Arrow Lake-S Core™ Ultra 200S Series (Max 65 W TDP)
- 2x DDR5 SODIMM/CSODIMM Sockets, Up to 6400MHz, 96GB
- Wide Operating Temperature -40°C to 60°C
- Optional CMI Modules for I/O Expansion
- Optional CFM Modules for Hardware TPM, Ignition Sensing & PoE

Next-Generation

Edge AI Computing Performance

The Intel® Core™ Ultra 200S series processors deliver up to 36 TOPS of AI computing performance through an integrated CPU, GPU, and NPU. This design, specifically for AI acceleration, delivers more than a 3.5x improvement over the previous generation platform.

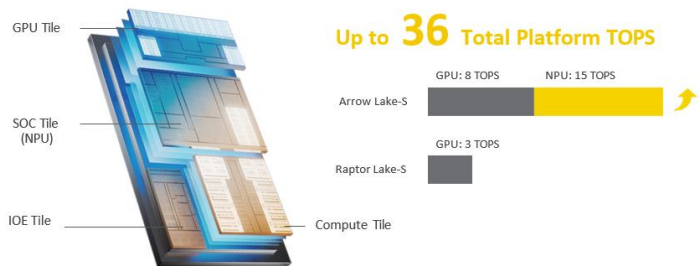

Compact Chassis

Measuring only 242 x 173 x 75mm, the compact chassis has a footprint comparable to an 11-inch iPad. This enables flexible deployment in space-constrained environments such as control cabinets, equipment interiors, or in-vehicle systems.

Rich & Versatile Expandability

Multiple built-in M.2 B/E key slots offer flexible support for wireless communication modules (5G, GNSS, Wi-Fi, Bluetooth), high-speed storage (NVMe SSD), and high-capacity storage (SATA SSD). It also supports I/O expansion modules, allowing for versatile configurations tailored to specific application needs.

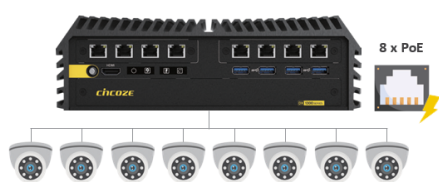

Stable, High-speed Data Transmission

Fast and reliable data transmission is crucial for applications such as image capture and surveillance. The DX-1300 supports multiple high-speed I/O ports, including 10/2.5/1 GbE LAN and USB 3.2. It can be expanded to support up to 12x LAN ports or 8x PoE, effectively simplifying cabling.

Rugged & Multi-vertical Certifications

The rugged design of the DX-1300 complies with military standards (MIL-STD-810H), railway certifications (EN 50121-3-2 & EN 45545-2), ensuring reliable operation in various harsh environments.



1.2 Specifications

Model Name	DX-1300
System	
Processor	<ul style="list-style-type: none"> • Arrow Lake-S Ultra 200S Series CPU: <ul style="list-style-type: none"> - Intel® Core™ Ultra 9 285 24 Cores Up to 5.6 GHz, TDP 65W - Intel® Core™ Ultra 9 285T 24 Cores Up to 5.4 GHz, TDP 35W - Intel® Core™ Ultra 7 265 20 Cores Up to 5.3 GHz, TDP 65W - Intel® Core™ Ultra 7 265T 20 Cores Up to 5.3 GHz, TDP 35W - Intel® Core™ Ultra 5 245 14 Cores Up to 5.1 GHz, TDP 65W - Intel® Core™ Ultra 5 245T 14 Cores Up to 5.1 GHz, TDP 35W - Intel® Core™ Ultra 5 225 10 Cores Up to 4.9 GHz, TDP 65W - Intel® Core™ Ultra 5 225T 10 Cores Up to 4.9 GHz, TDP 35W
Chipset	<ul style="list-style-type: none"> • Intel W880 Chipset
Memory	<ul style="list-style-type: none"> • 2x DDR5 SODIMM/CSODIMM Socket, Support Un-buffered and ECC Type <ul style="list-style-type: none"> - Ultra 9 / 7: Supports Up to 6400MHz, 96GB - Ultra 5: Supports Up to 5600MHz, 96GB
BIOS	<ul style="list-style-type: none"> • AMI BIOS
Graphics	
Graphics Engine	<ul style="list-style-type: none"> • Integrated Intel® Xe LPG Graphics
Maximum Display Output	<ul style="list-style-type: none"> • Supports Quad Independent Display
VGA	<ul style="list-style-type: none"> • 1x VGA Connector: 1920 x 1200 @ 60Hz
DP	<ul style="list-style-type: none"> • 1x DP Connector: 4096 x 2304 @ 60Hz <ul style="list-style-type: none"> - Support cable switch HDMI 4096 x 2160 @ 30Hz * Verified maximum resolution: 3840 x 2160 @ 60Hz
HDMI	<ul style="list-style-type: none"> • 1x HDMI Connector: 4096 x 2160 @ 30Hz <ul style="list-style-type: none"> * Verified maximum resolution: 3840 x 2160 @ 30Hz
Audio	
Audio Codec	<ul style="list-style-type: none"> • Realtek® ALC888, High Definition Audio
Line-out	<ul style="list-style-type: none"> • 1x Line-out, Phone Jack 3.5mm
Mic-in	<ul style="list-style-type: none"> • 1x Mic-in, Phone Jack 3.5mm
I/O	
LAN	<ul style="list-style-type: none"> • 2x 2.5 GbE LAN, RJ45 <ul style="list-style-type: none"> - GbE1~2: Intel® I226

COM	<ul style="list-style-type: none"> • 4x RS-232/422/485 with Auto Flow Control (Supports 5V/12V), DB9
USB	<ul style="list-style-type: none"> • 4x 10Gbps USB 3.2 Gen2x1, Type A • 4x 5Gbps USB 3.2 Gen1x1, Type A
Storage / Expansion	
2.5" SSD / HDD	<ul style="list-style-type: none"> • 2x 2.5" Front Accessible SATA HDD/SSD Bay (SATA 3.0)
M.2 Key B Socket	<ul style="list-style-type: none"> • 1x M.2 Key B Type 3042/3052 Socket (PCIe Gen 3x2 / USB3.2 Gen1x1 / SATA), Support 5G / GNSS / Storage / Add-on Card Expansion • 1x M.2 Key B Type 2242 Socket (PCIe Gen 4x2 / SATA / USB 2.0), Support Storage / Add-on Card Expansion
M.2 Key E Socket	<ul style="list-style-type: none"> • 1x M.2 Key E Type 2230 Socket (PCIe Gen 3x2 / USB2.0), Support Wireless / Bluetooth / Storage / Intel CNVi Module Expansion
SIM	<ul style="list-style-type: none"> • 1x SIM Socket
CMI (Combined Multiple I/O) Socket	<ul style="list-style-type: none"> • 2x High Speed CMI Interface for optional CMI Module Expansion • 1x Low Speed CMI Interface for optional CMI Module Expansion
CFM (Control Function Module) Socket	<ul style="list-style-type: none"> • 1x CFM-IGN Interface for optional CFM-IGN Module Expansion • 1x CFM-TPM Interface for optional CFM-TPM Module Expansion
Other Function	
RAID	<ul style="list-style-type: none"> • Support RAID 0/1/5/10
External FAN Connector	<ul style="list-style-type: none"> • 1x External FAN Connector, 4-pin Terminal Block (Support Smart Fan by BIOS)
Power Ignition Sensing	<ul style="list-style-type: none"> • Support Power Ignition Sensing Function with Delay Time Management and Selectable 12V/24V (With Optional CFM Module)
TPM	<ul style="list-style-type: none"> • Support Discrete TPM2.0 (with Optional CFM Module)
Clear CMOS Switch	<ul style="list-style-type: none"> • 1x Clear CMOS Switch
Reset Button	<ul style="list-style-type: none"> • 1x Reset Button
Instant Reboot	<ul style="list-style-type: none"> • Support 0.2 sec Instant Reboot Technology
Watchdog Timer	<ul style="list-style-type: none"> • Software Programmable Supports 256 Levels System Reset
Antenna Holes	<ul style="list-style-type: none"> • 3
Power	
Power Button	<ul style="list-style-type: none"> • 1x ATX Power On/Off Button
Power Mode Switch	<ul style="list-style-type: none"> • 1x AT/ATX Mode Switch
Power Input	<ul style="list-style-type: none"> • 9-48VDC, 3-pin Terminal Block
Remote Power On/Off	<ul style="list-style-type: none"> • 1x Remote Power On/Off, 2-pin Terminal Block

Remote Power LED	<ul style="list-style-type: none"> • 1x Remote Power LED, 2-pin Terminal Block
Max. Power Consumption	<ul style="list-style-type: none"> • 35W CPU: 162W • 65W CPU: 272.88W - Test conducted with CPU, 1x RAM, and 1x storage - 100% load during burn-in test
Inrush Current (Peak)	<ul style="list-style-type: none"> • 35W CPU: 5.24 A @ 24V • 65W CPU: 4.939 A @ 24V
Physical	
Dimension (W x D x H)	<ul style="list-style-type: none"> • 242.2 x 173 x 75mm
Weight Information	<ul style="list-style-type: none"> • 3.59 kg
Mechanical Construction	<ul style="list-style-type: none"> • Extruded Aluminum with Heavy Duty Metal
Mounting	<ul style="list-style-type: none"> • Wall / DIN-RAIL / VESA / Side Mount
Physical Design	<ul style="list-style-type: none"> • Fanless Design • Cableless Design • Jumper-less Design • Unibody Design
Reliability & Protection	
Reverse Power Input Protection	<ul style="list-style-type: none"> • Yes
Over Voltage Protection	<ul style="list-style-type: none"> • Protection Range: 51~58V • Protection Type: shut down operating voltage, re-power on at the preset level to recover
Over Current Protection	<ul style="list-style-type: none"> • 15A
CMOS Battery Backup	<ul style="list-style-type: none"> • SuperCap Integrated for CMOS Battery Maintenance-free Operation
MTBF	<ul style="list-style-type: none"> • 332,808 Hours - Database: Telcordia SR-332 Issue3, Method 1, Case 3
Operating System	
Windows	<ul style="list-style-type: none"> • Windows®11, Windows® 10
Linux	<ul style="list-style-type: none"> • Ubuntu 24.04
Environment	
Operating Temperature	<ul style="list-style-type: none"> • 35W TDP Processor: -40°C to 60°C (-40°F to 140°F) • 65W TDP Processor: -40°C to 50°C (-40°F to 122°F) With External Fan Kit - With extended temperature peripherals; Ambient with air flow - According to IEC60068-2-1, IEC60068-2-2, IEC60068-2-14

Storage Temperature	<ul style="list-style-type: none"> • -40°C to 85°C (-40°F to 185°F)
Relative Humidity	<ul style="list-style-type: none"> • 95% @ 60°C (non-Condensing)
Shock	<ul style="list-style-type: none"> • MIL-STD-810H
Vibration	<ul style="list-style-type: none"> • MIL-STD-810H
EMC	<ul style="list-style-type: none"> • CE, UKCA, FCC, ICES-003 Class A
EMI	<ul style="list-style-type: none"> • CISPR 32 Conducted & Radiated: Class A • EN/BS EN 50121-3-2 Conducted & Radiated: Class A • EN/BS EN IEC 61000-3-2 Harmonic current emissions: Class A • EN/BS EN61000-3-3 Voltage fluctuations & flicker • FCC 47 CFR Part 15B, ICES-003 Conducted & Radiated: Class A
EMS	<ul style="list-style-type: none"> • EN/IEC 61000-4-2 ESD: Contact: 6 kV; Air: 8 kV • EN/IEC 61000-4-3 RS: 80 MHz to 1000 MHz: 20 V/m • EN/IEC 61000-4-4 EFT: AC Power: 2 kV; DC Power: 1 kV; Signal: 2 kV • EN/IEC 61000-4-5 Surges: AC Power: 2 kV; Signal: 1 kV • EN/IEC 61000-4-6 CS: 10V • EN/IEC 61000-4-8 PF: 50 Hz, 30A/m • EN/IEC 61000-4-11 Voltage Dips & Voltage Interruptions: 1 cycle at 60 Hz
Railway	<ul style="list-style-type: none"> • EMC: EN 50155: 2021 Clause 4.4.6, 13.4.9 - EN 50121-1: 2017 - EN 50121-3-2: 2016 + A1: 2019
Industrial Environment	<ul style="list-style-type: none"> • EMC - EN/BS/IEC 61000-6-4: 2019 Class A - EN/BS/IEC 61000-6-2: 2019 (Compliant with additional power protection module)
Maritime Application	<ul style="list-style-type: none"> • EMC - IEC 60945 (Compliant with additional power protection module)
Fire Protection	<ul style="list-style-type: none"> • EN 45545-2
Safety	<ul style="list-style-type: none"> • UL, cUL, CB, IEC, EN 62368-1

** Product Specifications and features are for reference only and are subject to change without prior notice. For more information, please refer to the latest product datasheet from Cincoze's website.*

1.3 External Layout

1.3.1 Front

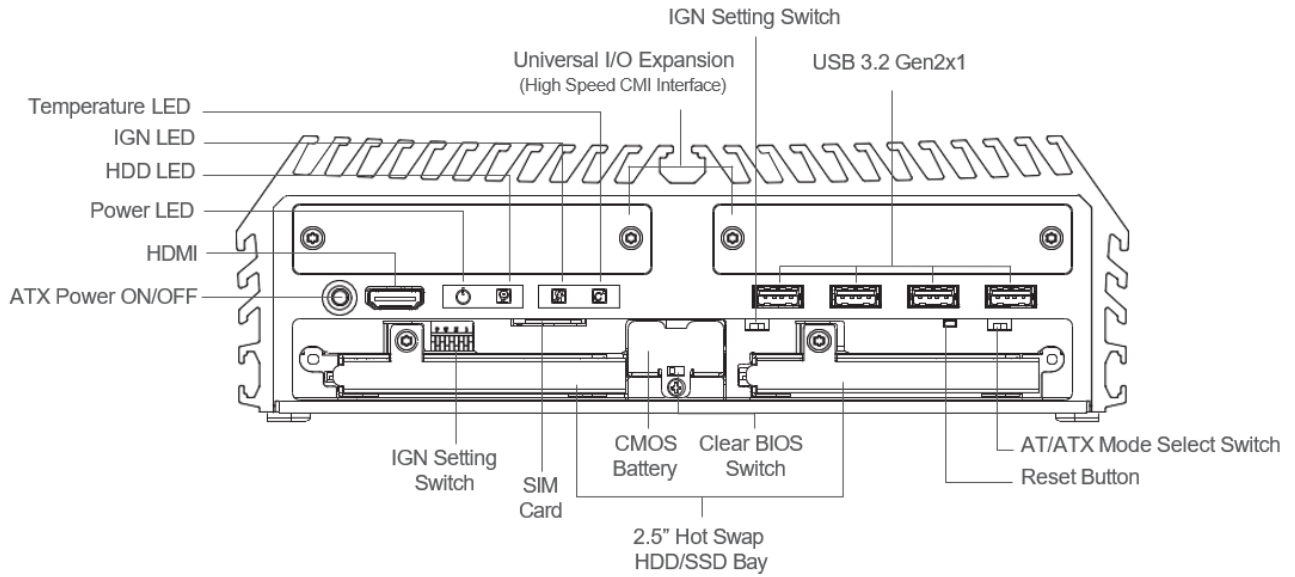

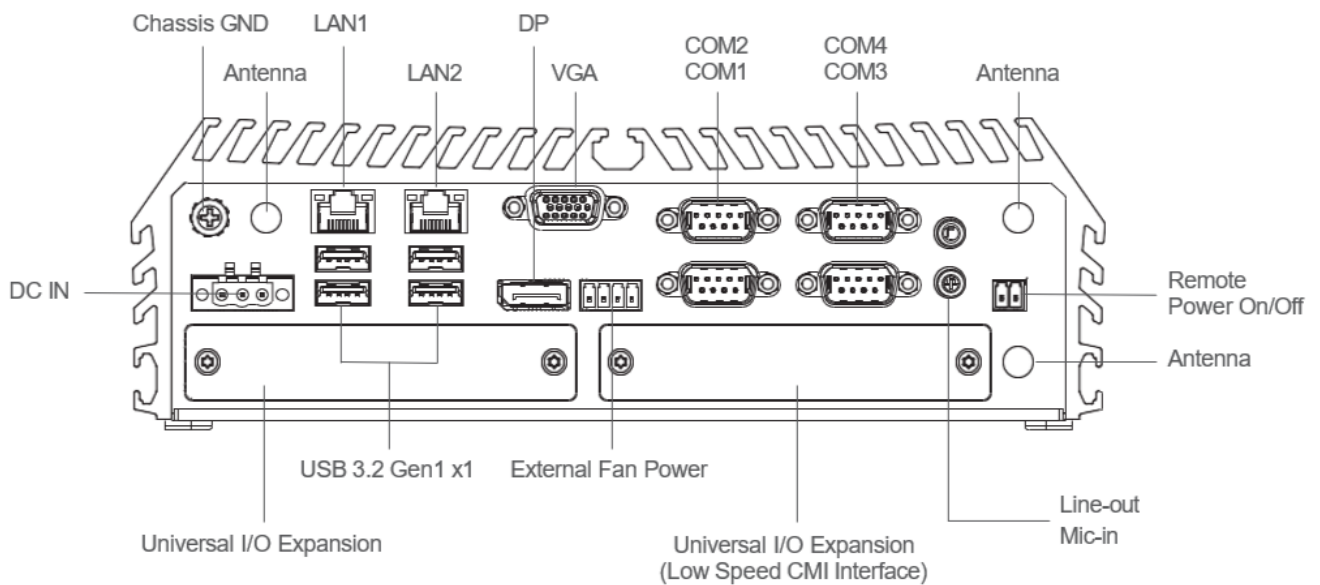

1.3.2 Rear

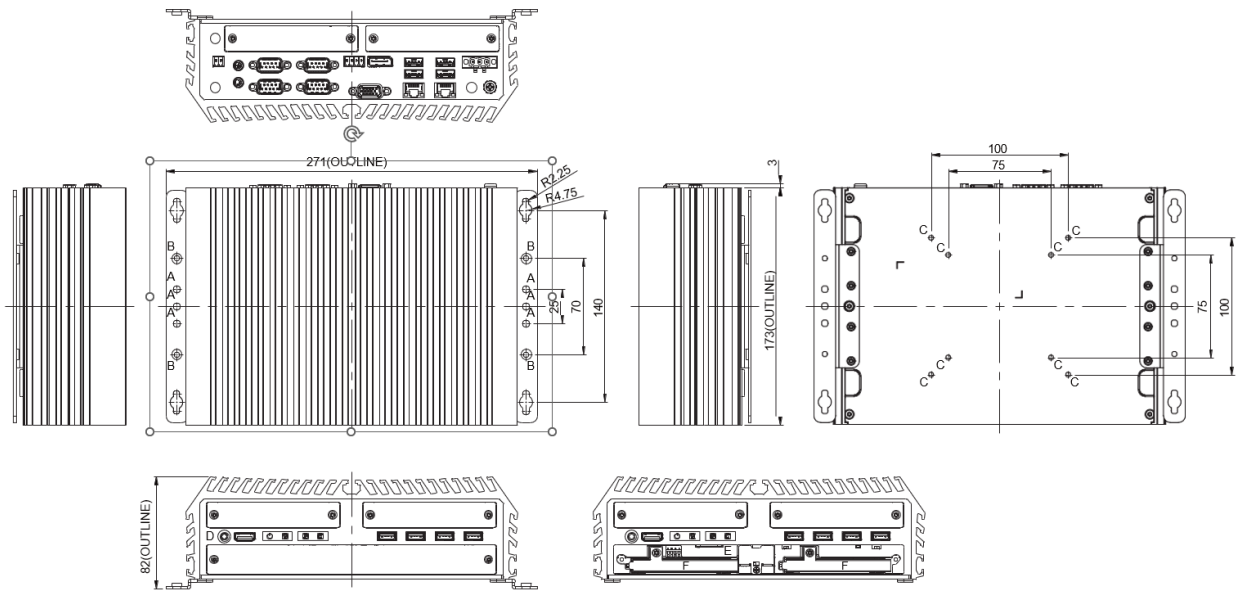

1.4 Dimensions

Unit: mm





Chapter 2

Switches & Connectors

2.1 Location of Switches and Connectors

2.1.1 Top View

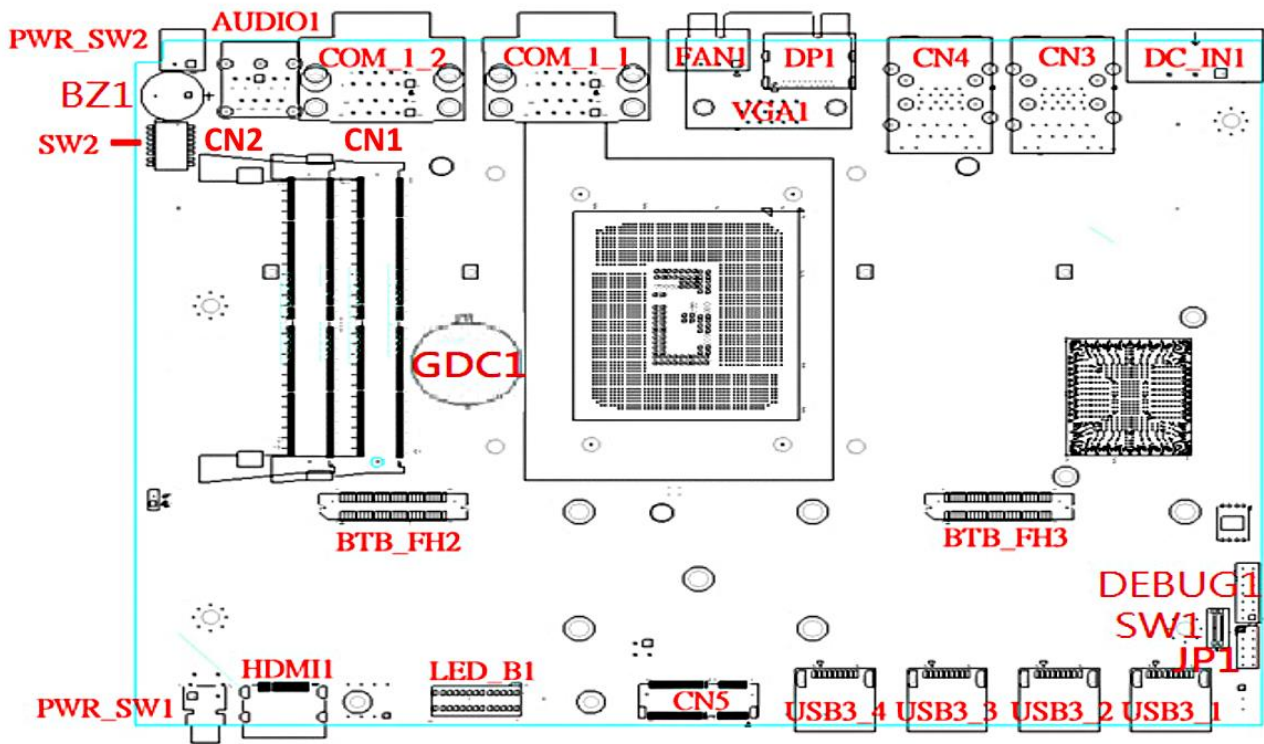

2.1.2 Bottom View

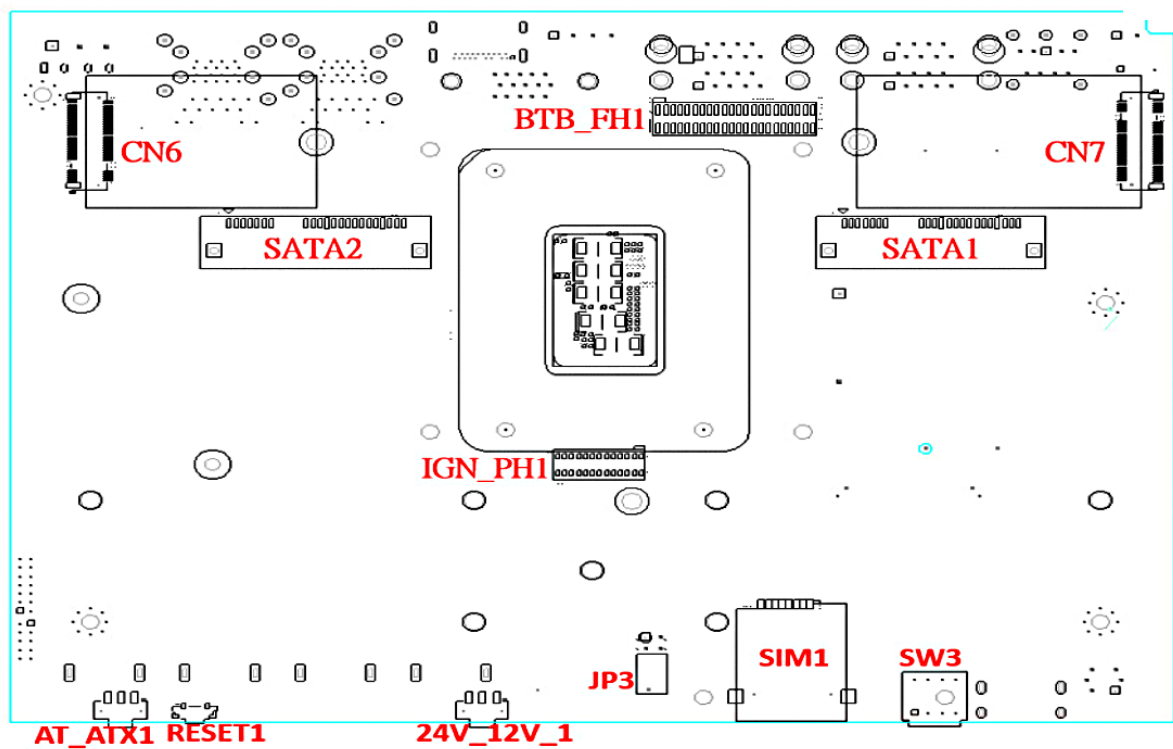

2.2 Switches and Connectors Definition

Connector	Definition
DC_IN1	DC +9V - 48V Power Connector
CN3/ CN4	LAN Connector + USB 3.2 Gen1 Connector
DP1	Display Port Connector
FAN1	Fan Connector
VGA1	VGA Connector
COM_1_1/ COM_1_2	COM1/COM2/COM3/COM4 Connector, supports RS232/RS422/RS485
AUDIO1	Audio Jack, MIC_IN/LINE_OUT
PWR_SW2	Power Button Connector
CN1/ CN2	DDR5 SO-DIMM Slot
GDC1	Super Cap for CMOS Backup
BTB_FH2/ BTB_FH3	PSE LAN Port Board to Board Connector
USB3_1/ USB3_2/ USB3_3/ USB3_4	USB 3.2 Gen2 Connector
CN5	M.2 Key E Type 2230 connector, supports PCIE/CNVi WiFi module
LED_B1	PWER_LED, HDD_LED, IGN_LED, TEMP_LED
HDMI1	HDMI Connector
PWR_SW1	Power Button
BZ1	Buzzer
SW2	COM1/ COM2/ COM3/ COM4 Power Select
DEBUG1	Debug Port Header
JP1	BIOS SPI interface
SW1	SuperCap switch
CN7	M.2 Key B Type 3052 connector, supports PCIE/ SATA/ USB3/ USB2/ SIM card
CN6	M.2 Key B Type 2242 connector, supports PCIE/ SATA/ USB2
BTB_FH1	DI/DO/DIO or COM5/ COM6 Port Board to Board Connector
SATA1/ SATA2	SATA Connector
SW3	IGN timing setting
SIM1	SIM card socket
JP3	RTC battery Board to Board connector
24V_12V_1	IGN, 12V/ 24V input switch
RESET1	Reset button
AT_ATX1	AT/ATX power mode switch
IGN_PH1	IGN Board to Board connector

2.3 Definition of Switches

AT_ATX1: AT / ATX Power Mode Switch

Switch	Definition
1-2 (Left)	AT Power Mode
2-3 (Right)	ATX Power Mode (Default)



Reset1: System Reset Button

Button	Definition
Push	Reset System



PWR_SW1: ATX Power on/off Button

Switch	Definition
Push	Power on System



SW1: Super CAP Switch

DIP	Function	ON	OFF
1	Super CAP	Enable (Default)	Disable
2		Enable (Default)	Enable



CLR_CMOS1: Clear CMOS Switch

Pin	Definition
1-2 (Left)	Normal Status (Default)
2-3 (Right)	Clear CMOS



WARNING
(AVERTIR)

After performing Clear CMOS, the system will take several minutes to start. This is normal. During this process, the system will POST three times, and the system's Power LED will alternate between green and blue lights.

(Après avoir effectué Clear CMOS, le système prendra plusieurs minutes pour démarrer. Cela est normal. Pendant ce processus, le système effectuera trois fois le POST, et la LED d'alimentation du système alternera entre les lumières verte et bleue.)

SW2: COM1~COM4 Power Select

COM1 / 2 / 3 / 4 Voltage Function Setting via DIP Switch

Function		DIP1	DIP2
COM1	RI	ON (Default)	ON (Default)
	5V	ON	OFF
	12V	OFF	OFF

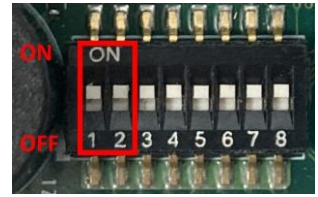

Function		DIP3	DIP4
COM2	RI	ON (Default)	ON (Default)
	5V	ON	OFF
	12V	OFF	OFF

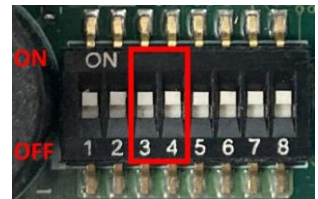

Function		DIP5	DIP6
COM3	RI	ON (Default)	ON (Default)
	5V	ON	OFF
	12V	OFF	OFF

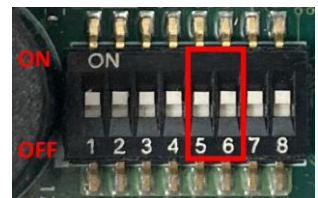

Function		DIP7	DIP8
COM4	RI	ON (Default)	ON (Default)
	5V	ON	OFF
	12V	OFF	OFF

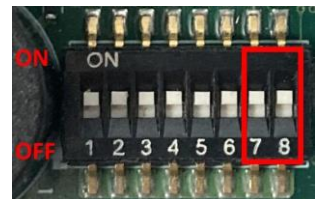

2.4 Definition of Connectors

CN5: M.2 Key E Socket (PCIE / CNVi WIFI)

Pin No.	PIN Name	Pin NO.	Pin name
1	GND	2	3.3V
3	USB_D+	4	3.3V
5	USB_D-	6	NC
7	GND	8	PCM_CLK
9	WGR_D1N	10	PCM_SYNC
11	WGR_D1P	12	PCM_IN
13	GND	14	PCM_OUT
15	WGR_D0N	16	NC
17	WGR_D0P	18	GND
19	GND	20	UART_WAKE
21	WGR_CLKN	22	BRI_RSP
23	WGR_CLKP	24	Key
25	Key	26	Key
27	Key	28	Key
29	Key	30	Key
31	Key	32	RGI_DT
33	GND	34	RGI_RSP
35	PETP0	36	BRI_DT
37	PETN0	38	CLINK_REST
39	GND	40	CLINK_DATA
41	PERP0	42	CLINK_CLK
43	PERN0	44	COEX3
45	GND	46	COEX_TXD
47	REFCLKP0	48	COEX_RXD
49	REFCLKN0	50	SUSCLK
51	GND	52	PERST0#
53	NC	54	NC
55	PEWAKE0#	56	W_DISABLE1#
57	GND	58	I2C_DATA
59	WTD1N/PETP1	60	I2C_CLK
61	WTD1P/PETN1	62	NC
63	GND	64	NC

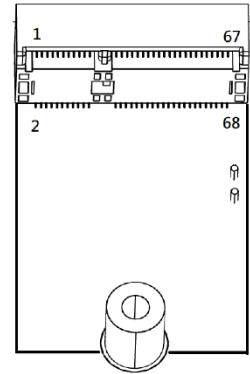

65	WT_D0N/PERP1	66	NC
67	WT_D0P/PERN1	68	NC
69	GND	70	PEWAKE1#
71	WTCLKN/REFCLKP1	72	3.3V
73	WTCLKP/REFCLKN1	74	3.3V
75	GND		

CN6: M.2 Key B Type 2242 Connector (PCIE/SATA/USB2)

Pin No.	PIN Name	Pin No.	Pin name
1	CFG3	2	+3.3V
3	GND	4	+3.3V
5	GND	6	NC
7	USB2_D+	8	NC
9	USB2_D-	10	LED#1
11	GND	12	Key
13	Key	14	Key
15	Key	16	Key
17	Key	18	Key
19	Key	20	NC
21	CFG0	22	NC
23	NC	24	NC
25	NC	26	NC
27	GND	28	NC
29	PERN1	30	USIM1_RST
31	PERP1	32	USIM1_CLK
33	GND	34	USIM1_DATA
35	PETN1	36	USIM1_PWR
37	PETP1	38	DEVSLP
39	GND	40	SIM2_DET
41	PERN0/SATA_RXP	42	USIM2_DATA
43	PERP0/SATA_RXN	44	USIM2_CLK
45	GND	46	USIM2_RST
47	PETN0/SATA_TXN	48	USIM2_PWR
49	PETP0/SATA_TXP	50	PERST#
51	GND	52	CLKREQ#
53	REFCLKN	54	WAKE#
55	REFCLKP	56	NC
57	GND	58	NC
59	NC	60	NC

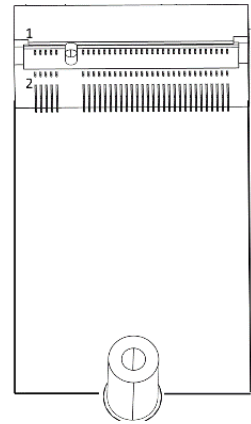

61	NC	62	NC
63	NC	64	NC
65	NC	66	SIM1_DET
67	RESET2#	68	SUSCLK
69	CFG1	70	+3.3V
71	GND	72	+3.3V
73	GND	74	+3.3V
75	CFG2		

CN7: M.2 Key B Type 3052 Connector (PCIE/SATA/USB3/USB2)

Pin No.	PIN Name	Pin No.	Pin name
1	CFG3	2	+3.3V
3	GND	4	+3.3V
5	GND	6	NC
7	USB2_D+	8	NC
9	USB2_D-	10	LED#1
11	GND	12	Key
13	Key	14	Key
15	Key	16	Key
17	Key	18	Key
19	Key	20	NC
21	CFG0	22	NC
23	NC	24	NC
25	NC	26	NC
27	GND	28	NC
29	PERN1	30	USIM1_RST
31	PERP1	32	USIM1_CLK
33	GND	34	USIM1_DATA
35	PETN1	36	USIM1_PWR
37	PETP1	38	DEVSLP
39	GND	40	SIM2_DET
41	PERN0/SATA_RXP	42	USIM2_DATA
43	PERP0/SATA_RXN	44	USIM2_CLK
45	GND	46	USIM2_RST
47	PETN0/SATA_TXN	48	USIM2_PWR
49	PETP0/SATA_TXP	50	PERST#
51	GND	52	CLKREQ#
53	REFCLKN	54	WAKE#
55	REFCLKP	56	NC
57	GND	58	NC

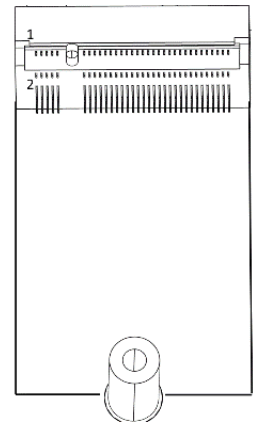



59	NC	60	NC
61	NC	62	NC
63	NC	64	NC
65	NC	66	SIM1_DET
67	RESET2#	68	SUSCLK
69	CFG1	70	+3.3V
71	GND	72	+3.3V
73	GND	74	+3.3V
75	CFG2		

DC_IN1: DC Power Input Connector (+9-48V)

Connector Type: Terminal Block 1x3 3-pin, 5.0mm pitch

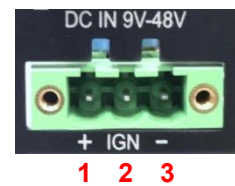
Pin	Definition
1	9_48VSB_IN
2	Ignition (IGN)
3	GND





CAUTION
(ATTENTION)

Please disconnect the power source before mounting the DC power cables or connecting the DC power connector to system.

(Veuillez débrancher la source d'alimentation avant de monter les câbles d'alimentation CC ou de connecter le connecteur d'alimentation CC au système.)

PWR_SW2: Power On/Off Switch Connector

Connector Type: Terminal Block 1x2 2-pin, 3.5mm pitch

Pin	Definition
1	PWR_SW
2	GND

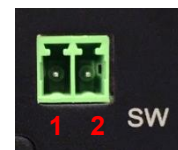



WARNING
(AVERTIR)

Do not apply power to this connector! This port is used to connect a SWITCH!

(Ne mettez pas sous tension ce connecteur! Ce port est utilisé pour connecter un SWITCH!)

CN3 / CN4: LAN1 / 2 LED Status Definition

Link Act LED Status	Definition
Blinking Yellow	Link and Data Activity
Steady Yellow	Link but No Activity
Off	No Link
Link Speed LED Status	Definition
Steady Green	2.5 Gbps Network Link
Steady Orange	1 Gbps Network Link
Off	10/ 100 Mbps Network Link

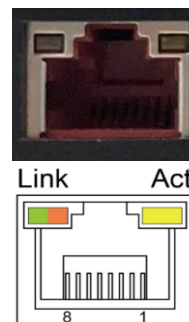

FAN1: External Fan Connector

Connector Type: Terminal Block 1x4 4-pin, 3.5mm pitch

Pin	Definition
1	GND
2	+12V
3	SENSE
4	Control



COM1~COM4: RS232 / RS422 / RS485 Connector

Connector Type: 9-pin D-Sub

Pin	RS232 Definition	RS422 / 485	
		Full Duplex Definition	Half Duplex Definition
1	DCD	TX-	DATA -
2	RXD	TX+	DATA +
3	TXD	RX+	
4	DTR	RX-	
5	GND		
6	DSR		
7	RTS		
8	CTS		
9	RI		



LED_B1: PWR / HDD / IGN / TEMP LED Status

LED B1	Status	LED Color	
Power LED	Power ON	Green	
	Standby	Blinking Green & Blue	
	Power Off	Blue	
HDD LED	HDD Read/Write	Blinking Yellow	
IGN LED	IGN module not installed	No light	
	IGN module installed	IGN disabled	Green
		IGN enabled	ACC OFF
		ACC ON	Green
TEMP LED	System Temp $\leq 73^{\circ}\text{C}$	Off	
	$73^{\circ}\text{C} < \text{System Temp} \leq 81^{\circ}\text{C}$	Blue	
	$81^{\circ}\text{C} < \text{System Temp} \leq 83^{\circ}\text{C}$	Red	
	$83^{\circ}\text{C} < \text{System Temp}$	Blinking Red	



**NOTE
(NOTE)**

**The TEMP LED is only available when IGN module is installed.
(La LED TEMP n'est disponible que lorsque le module IGN est installé.)**

2.5 Optional Modules: Definition of Switches and Connectors

2.5.1 CMI-M12LAN01-R12/ UB1710-R10

Connector Type: M12 A coded 8pin connector

Pin	Definition	Pin	Definition
1	2_LAN1_0+	2	2_LAN1_0-
3	2_LAN1_1+	4	2_LAN1_2+
5	2_LAN1_2-	6	2_LAN1_1-
7	2_LAN1_3+	8	2_LAN1_3-

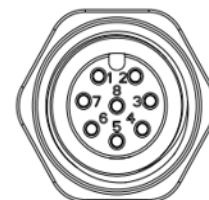

2.5.2 CMI-XM12LAN01-R10/ UB0930-R10

Connector Type: M12 X coded 8pin connector

Pin	Definition	Pin	Definition
1	D1+	2	D1-
3	D2+	4	D2-
5	D4+	6	D4-
7	D3-	8	D3+

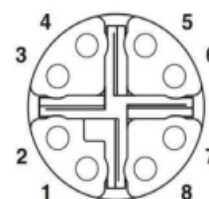

2.5.3 CMI-2P5GLAN01-R10/UB1712

LAN LED Status Definition

Link Speed LED Status	Definition
Steady Green	2.5 Gbps Network Link
Steady Orange	1 Gbps Network Link
Off	100 Mbps Network Link
Off	10 Mbps Network Link
Link Act LED Status	Definition
Blinking Yellow	Link and Data Activity
Steady Yellow	Link but No Activity
Off	No Link

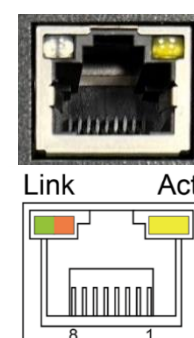

2.5.4 CMI-10GXM12LAN01-R10/UB1737

LAN (X550) LED Status Definition

Link Speed LED Status	Definition
Steady Green	10 Gbps Network Link
Steady Orange	1 Gbps Network Link
Off	100 Mbps Network Link
Link Act LED Status	Definition
Blinking Yellow	Link and Data Activity
Steady Yellow	Link but No Activity
Off	No Link

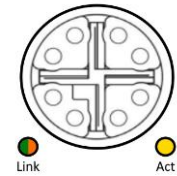

LAN Port Pin Definitions

Connector Type: M12 X coded 8pin connector

Pin	Definition	Pin	Definition
1	MDX0+	2	MDX0-
3	MDX1+	4	MDX1-
5	MDX3+	6	MDX3-
7	MDX2-	8	MDX2+
9	GND		

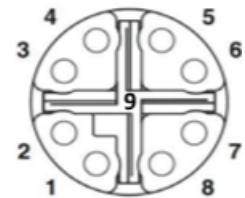

2.5.5 CMI-COM01/UB1303

COM5 / COM6: RS232 / RS422 / RS485 Connector

Connector Type: 9-pin D-Sub

Pin	RS232 Definition	RS422 / 485 Full Duplex Definition	RS485 Half Duplex Definition
1	DCD	TX-	DATA -
2	RXD	TX+	DATA +
3	TXD	RX+	
4	DTR	RX-	
5	GND		
6	DSR		
7	RTS		
8	CTS		
9	RI		



SW2: COM5/COM6 Power Select

Location	Function	DIP1	DIP2
SW2 on CMI-COM Module	0V(RI)	ON (Default)	ON (Default)
	5V	ON	OFF
	12V	OFF	OFF

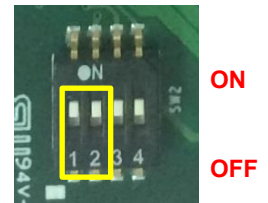

Location	Function	DIP3	DIP4
SW2 on CMI-COM Module	0V(RI)	ON (Default)	ON (Default)
	5V	ON	OFF
	12V	OFF	OFF

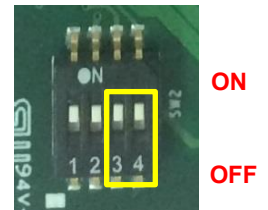

2.5.6 CFM-IGN01

SW3: IGN Module Timing Setting Switch

Set shutdown delay timer when ACC is turned off

Pin 1	Pin 2	Pin 3	Pin 4	Definition	
ON	ON	ON	ON (IGN enabled)	0 second	
ON	ON	OFF		1 minute	
ON	OFF	ON		5 minutes	
ON	OFF	OFF		10 minutes	
OFF	ON	ON		/	30 minutes
OFF	ON	OFF		OFF	1 hour
OFF	OFF	ON		(IGN disabled)	2 hours
OFF	OFF	OFF			Reserved (0 second)

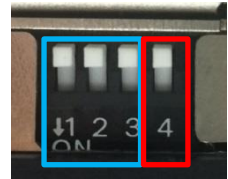

OFF
ON

24V_12V_1: IGN Module Voltage Mode Setting Switch

12V / 24V Car Battery Switch

Pin	Definition
1-2 (right)	24V Car Battery Input (Default)
2-3 (left)	12V Car Battery Input



2.5.7 CMI-DIO01

DIO1/DIO2: Digital Input / Output Connector

Connector Type: Terminal Block 2X10 10-pin, 3.5mm pitch

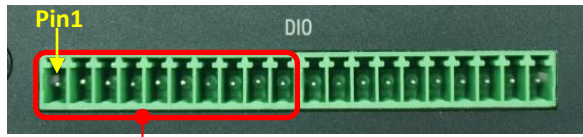

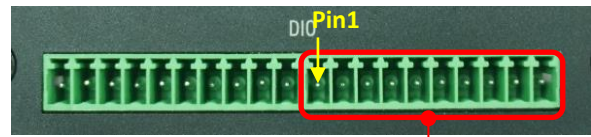

DIO1 (Digital Input)



DIO2 (Digital Input)

Location	Pin	Definition
DIO1	1	DC INPUT (XCOM+)
	2	DI1
	3	DI2
	4	DI3
	5	DI4
	6	DI5
	7	DI6
	8	DI7
	9	DI8
	10	GND (XCOM-)

Location	Pin	Definition
DIO2	1	DC INPUT (XCOM+)
	2	DO1
	3	DO2
	4	DO3
	5	DO4
	6	DO5
	7	DO6
	8	DO7
	9	DO8
	10	GND (XCOM-)



Chapter 3

System Setup

3.1 Removing Top Cover



WARNING
(AVERTIR)

To prevent electric shock or system damage, turn off the power and disconnect the unit from its power source before removing the chassis cover.

(Pour éviter tout choc électrique ou dommage au système, éteignez l'alimentation et débranchez l'appareil de sa source d'alimentation avant de retirer le capot du châssis.)

Step 1. Flip the system upside down. Remove the 6 screws on the bottom cover.



Step 2. Remove the bottom cover from the chassis.



Step 3. Loosen but do not remove the 4 screws, then pull the 4 latches as indicated below.

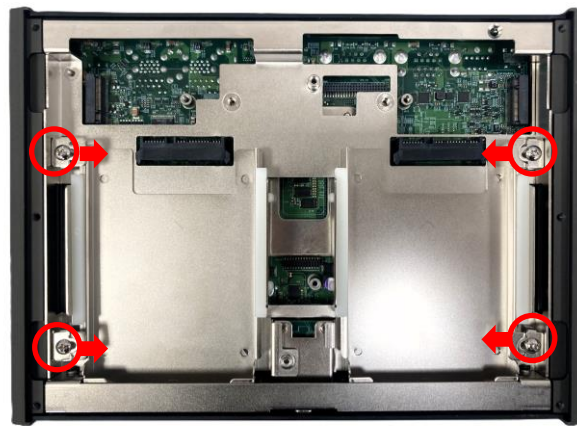

Step 4. Hold the front and rear panels and lift the body of the system.



Step 5. Flip the system upright and set it to the side.



3.2 Installing CPU



WARNING
(AVERTIR)

After replacing the CPU, please perform a Clear CMOS before powering on. According to Intel documentation (Clear CMOS after Hardware Configuration Change, Document Number: 337986-001), if you do not perform a Clear CMOS, the BIOS will apply settings from the old CPU to the new CPU, which may cause performance issues or startup failures. Therefore, Cincoze performs a Clear CMOS procedure before shipping. When customers power on the system for the first time, it will take several minutes to start. This is normal. During this process, the system will POST three times, and the Power LED will alternate between green and blue lights.

(Après avoir remplacé le CPU, veuillez effectuer un Clear CMOS avant de mettre sous tension. Selon la documentation Intel (Clear CMOS after Hardware Configuration Change, Document Number: 337986-001), si vous n'effectuez pas un Clear CMOS, le BIOS appliquera les paramètres de l'ancien CPU au nouveau CPU, ce qui peut entraîner des problèmes de performance ou des échecs de démarrage. Par conséquent, Cincoze effectue une procédure de Clear CMOS avant l'expédition. Lorsque les clients mettent le système sous tension pour la première fois, il faudra plusieurs minutes pour démarrer. Cela est normal. Pendant ce processus, le système effectuera trois fois le POST et la LED d'alimentation alternera entre les lumières verte et bleue.)

Step 1. Locate the CPU socket.

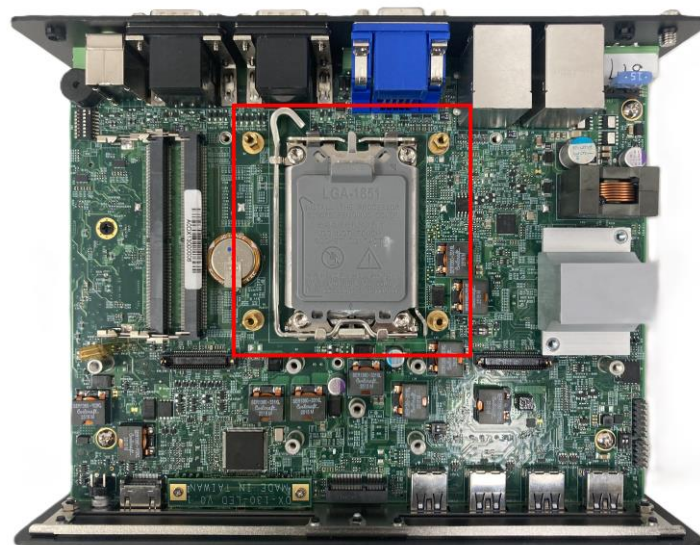

Step 2. Press the lever down and to the side, then up.



Step 3. Lift the CPU bracket using the lever.

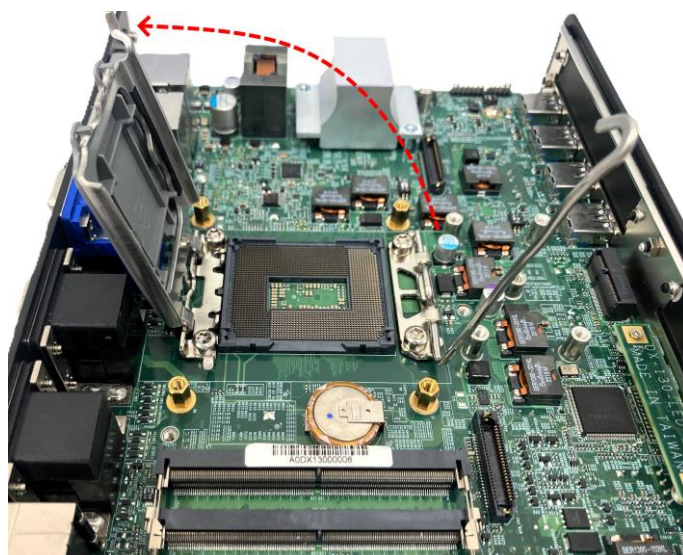

Step 4. Align the CPU with the fool-proof protrusions on the socket and gently seat the CPU.

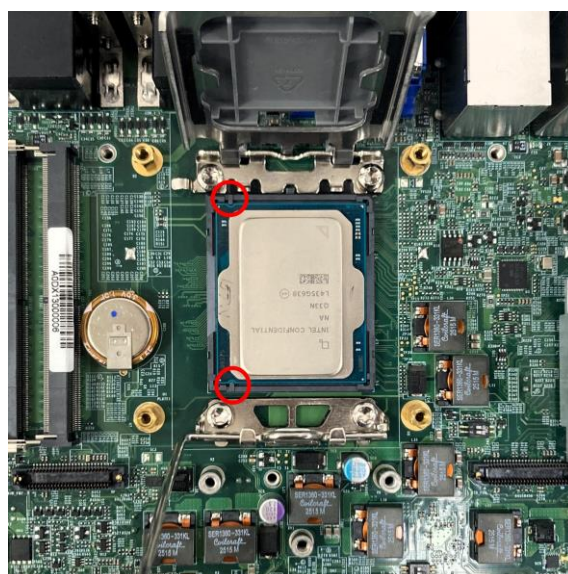

Step 5. Press down on the bracket, then lock the lever back into its original place. The CPU socket cover will detach automatically. Set the cover aside for future use.

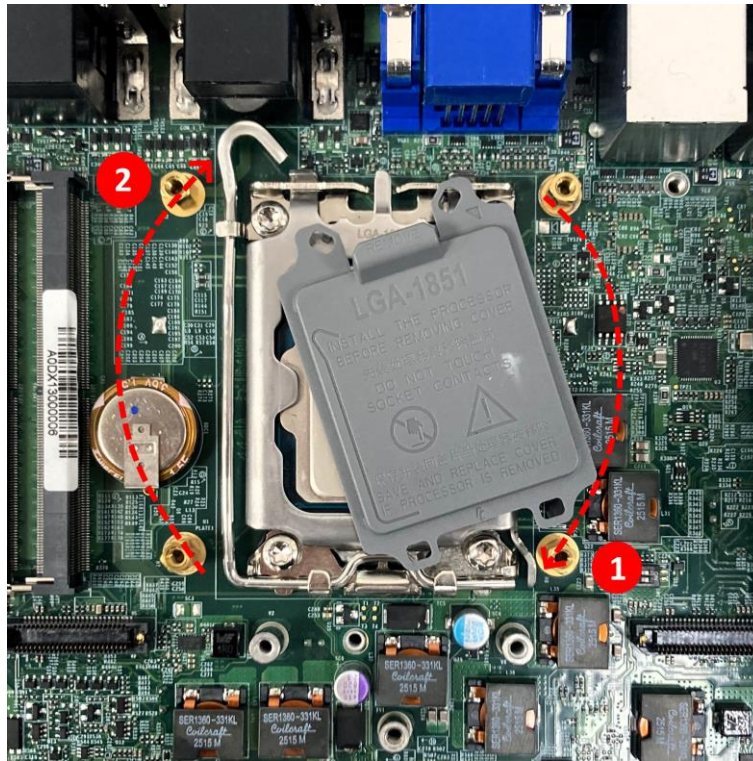

Step 7. Ensure that the CPU is clean, then apply thermal paste onto the center of the CPU as shown below. For more information about thermal paste application, refer to the support article on [Intel's official website](#).



Step 8. Place the thermal block onto the CPU, ensuring the front arrow points towards the front of the system.

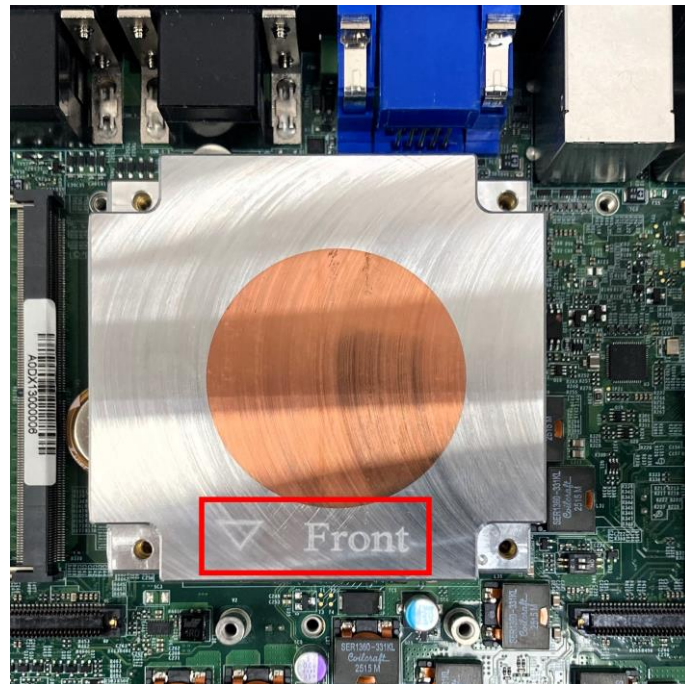

Step 9. Align the mounting holes on the CPU heatsink with the standoffs and secure the heatsink with 4 screws.

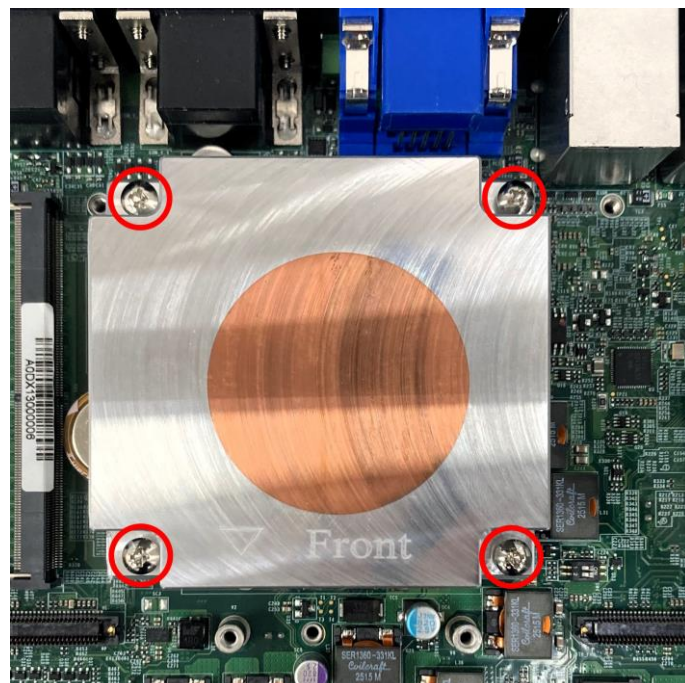

Step 10. Peel off the protective transparent films on both sides of the thermal pad, then paste the thermal pad onto the thermal block.

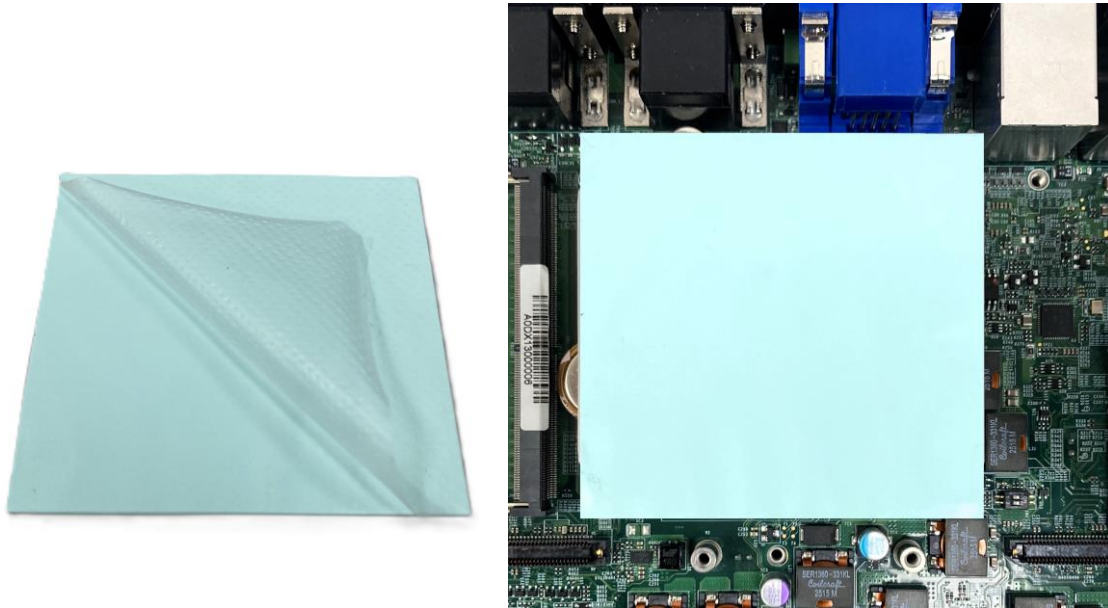

CAUTION
(ATTENTION)

Before assembling the system's chassis cover, please make sure the protective film on the Thermal Pad has been removed!

(Avant d'assembler le couvercle du châssis du système, assurez-vous que le film protecteur sur le coussin thermique a été retiré !d'alimentation CC au système.)

3.3 Installing SO-DIMM Memory

Step 1. Locate the SODIMM sockets on the top side of the system.

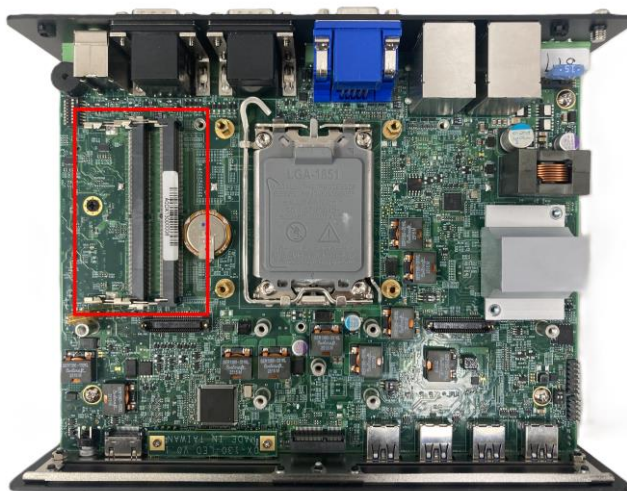

Step 2. Insert a SO-DIMM at a 45-degree angle until it is firmly seated in the socket.



Lower socket

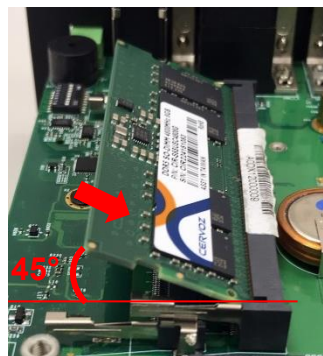

Upper socket

Step 3. Press down the module until the retaining clips snap back in place.



Lower socket



Upper socket

3.4 Installing M.2 Key B Module

3.4.1 CN7 (M.2 Key B Type 3052/ 3042/ 2242)

Step 1. Locate the M.2 Key B Type 3052 socket (CN7) on the bottom side of the system. This slot supports M.2 Type 3052, 3042, and 2242 modules.

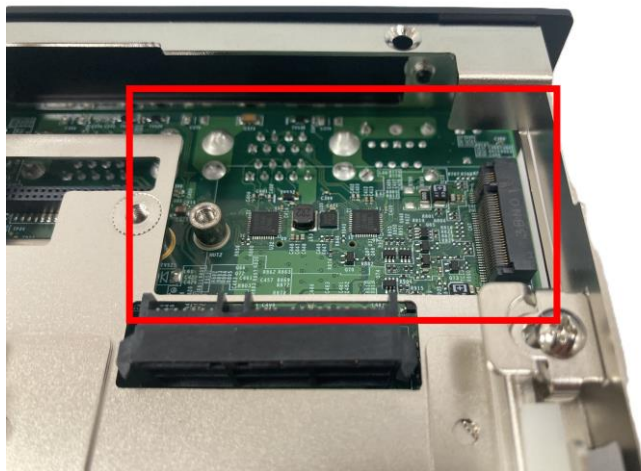

Step 2. Align the M.2 Key B Type 3052 to 2242 Adapter Bracket (included in the Package) with the corresponding screw hole. Secure the bracket in place and fasten the screw (M3x4L).

Skip this step when using an M.2 Type 3052 module.



Step 3. Insert the M.2 Key B module at a 45-degree angle until it is firmly seated in the socket.



Step 4. Press down on the module and secure it with a screw.



3.4.2 CN6 (M.2 Key B type 2242)

Step 1. Locate the M.2 Key B Type 2242 socket (CN6) on the bottom side of the system. This slot only supports M.2 Type 2242 modules.

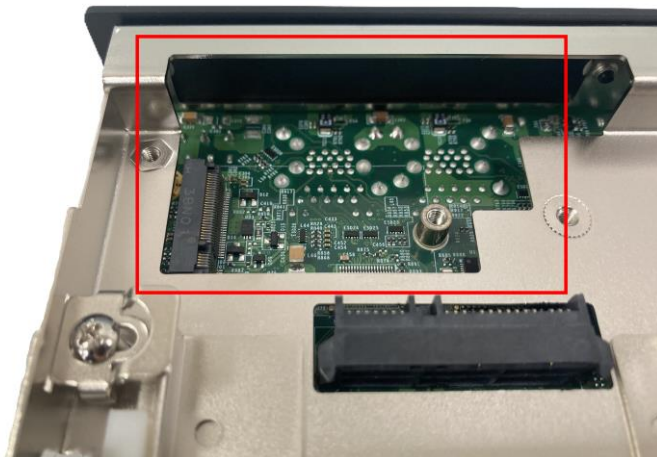

Step 2. Insert the M.2 Key B module at a 45-degree angle until it is firmly seated in the socket.



Step 3. Press down on the module and secure it with a screw.



3.5 Installing M.2 Key E Module

Step 1. Locate the M.2 E Key slot (CN5) on the system motherboard.

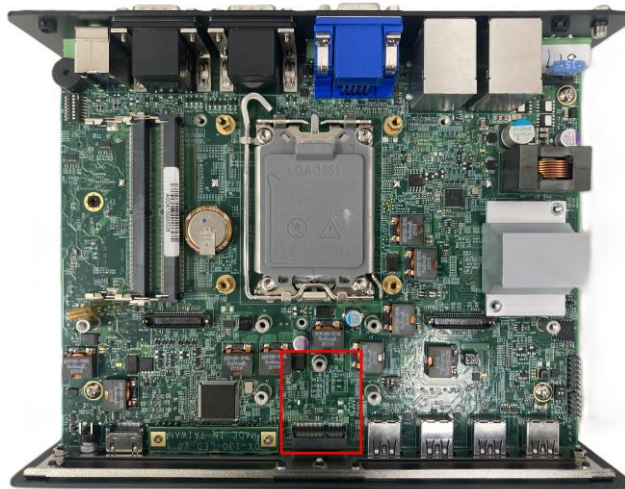

Step 2. Insert the M.2 Key E module at a 45-degree angle into the socket until it is firmly seated.



Step 3. Press down on the module and secure it with a screw.

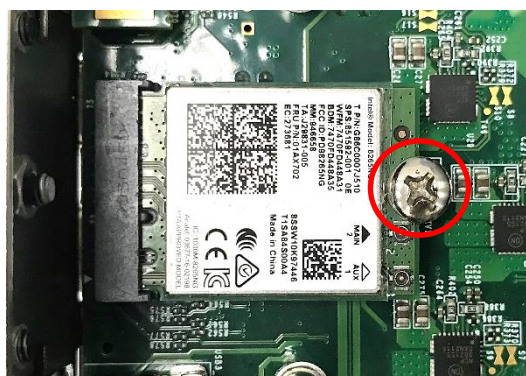

3.6 Installing Antenna(s)

For antennas 1 and 2, please refer to section 3.6.1. For antenna 3, please refer to section 3.6.2.

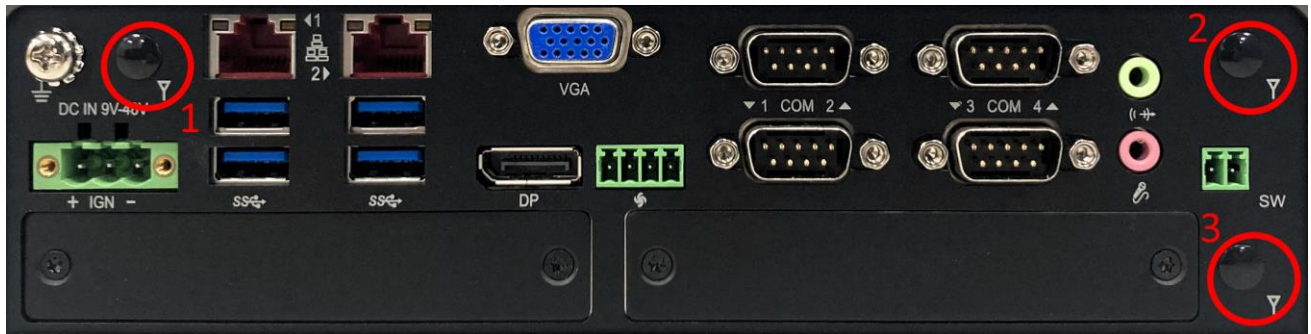

3.6.1 Antennas 1 and 2

In this section, antenna 2 is used as an example.

Step 1. Remove the antenna cover on the rear panel.



Step 2. Slot the antenna jack through the cutout.

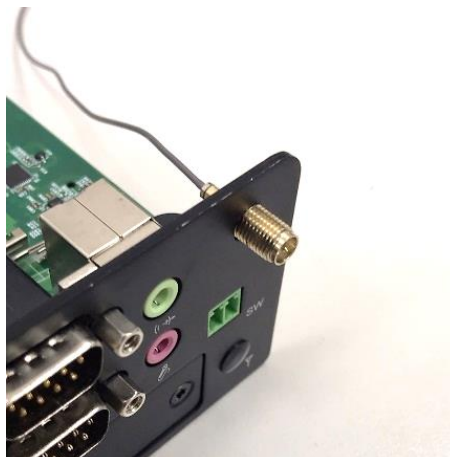

Step 3. Thread the washer and the nut onto the antenna jack until they sit flush against the rear panel.



Step 4. Assemble the antenna and antenna jack.



Step 5. Attach the RF connector cable to the Wireless card to complete installation.



3.6.2 Antenna 3

Step 1. Remove the antenna cover on the rear panel.



Step 2. Remove the 10 D-Sub jack screws on the rear panel, then remove the rear panel.



Step 3. Slot the antenna jack through the cutout.



Step 4. Reassemble the rear panel and secure it with 10 D-Sub jack screws.



Step 5. Thread the washer and the nut onto the antenna jack until they sit flush against the rear panel.



Step 6. Assemble the antenna and antenna jack.



Step 7. Attach the RF connector cable to the Wireless card to complete installation.



3.7 Installing Antenna Cutout Universal Bracket

An optional Universal Bracket (UB0932) features three antenna cutouts for 5G/4G card expansion. This bracket allows users to mount antennas in the designated cutouts.

Step 1. Loosen and remove the two screws from either the left or right bracket of the system's front or rear panel. In this example, the front left UB panel is used.



Step 2. Attach the I/O bracket onto the system as indicated below, and fasten the screws to secure it. For antenna installation, please refer to section 3.6.

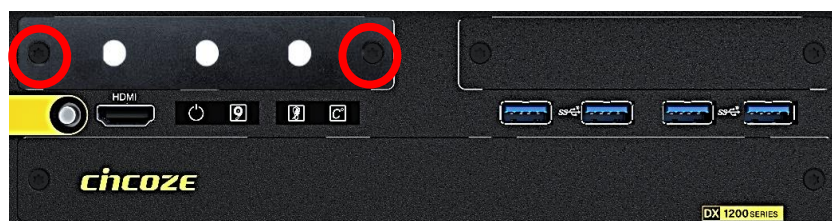

3.8 Installing Covers

Step 1. Set the top cover upside down. Ensure that the top cover and the system chassis are aligned.



Step 2. Flip the system chassis upside down and align the front and rear panels with the grooves in the top cover. Lower the system chassis onto the top cover.



Step 3. Push the 4 latches as indicated below, then secure the screws.

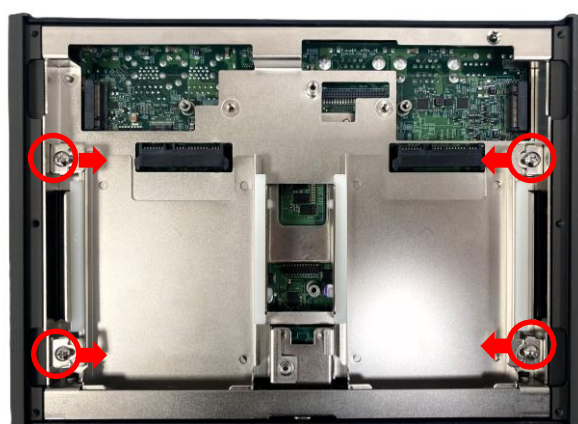

Step 5. Align the grooves of the bottom cover with the front and rear panels, then secure it with 6 screws.



3.9 Installing SATA HDD/SSD

Step 1. Loosen the two screws to remove the cover plate of the maintenance zone.



Step 2. Remove the screw to unlock the left or right HDD bay cover bracket. In this example, the left HDD bay is used.

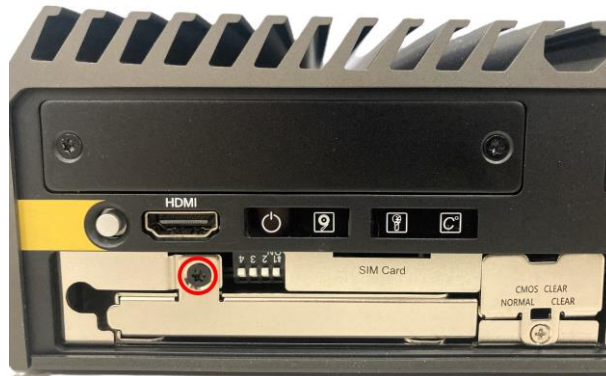

Step 3. Pull the rotating arm to the right and pull the HDD bracket out of the system.



Step 4. Set the HDD upside down with the four bottom mount screw holes facing up. Place the HDD bracket over the HDD, ensuring the HDD is positioned correctly. Secure the HDD to the HDD bracket with four screws as indicated below.

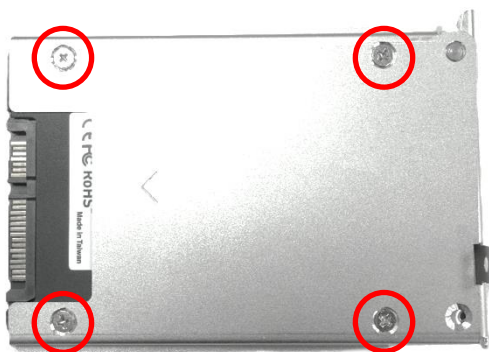

Step 5. Align the HDD bracket with the entrance of the HDD bay. Insert the HDD bracket and push it until the HDD connector is fully inserted into the SATA slot.



Step 6. Close the HDD bracket and secure it with a screw.

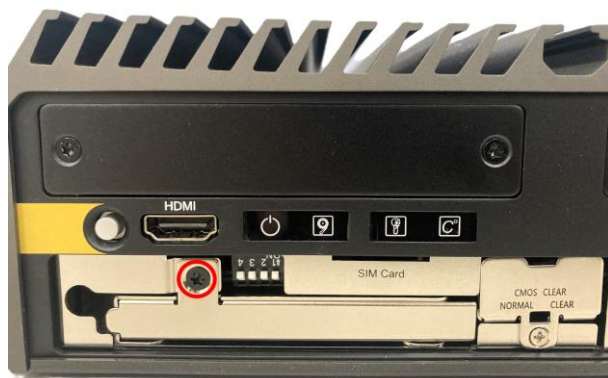

Step 7. Reinstall the maintenance zone cover plate and secure it with two screws.



3.10 Installing SIM Card

Step 1. Loosen the two screws to remove the cover plate of the maintenance zone.



Step 2. Locate the SIM card slot.

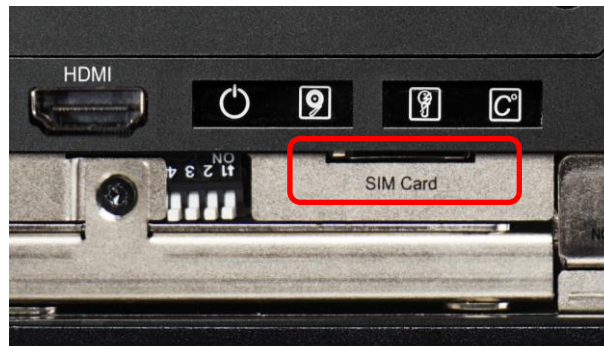

Step 3. Insert a SIM card into the SIM slot with the gold contacts facing up (see below).



Step 4. Reinstall the maintenance zone cover plate and secure it with two screws.



3.11 Replacing CMOS Battery

Step 1. Loosen the two screws to remove the cover plate of the maintenance zone.



Step 2. Locate the removable CMOS battery bracket and loosen the screw.



Step 3. Pull out the CMOS battery bracket. A tweezer is recommended.

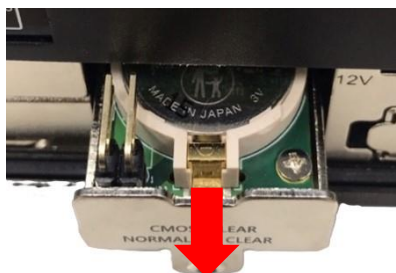

Step 4. Remove the battery by pressing the metal tab backwards as indicated.

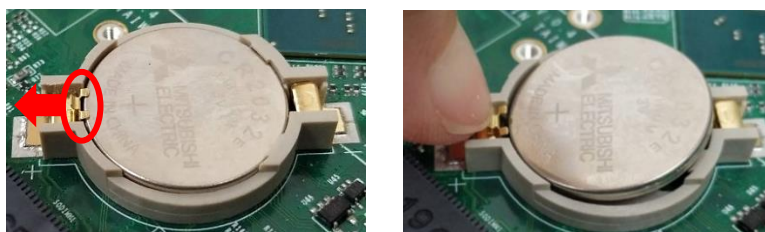

Step 5. Note the direction of “+” and “-” signs on the battery. Push the battery into the slot from the "-" side and pull the metal tab backwards to firmly seat the battery in the holder.

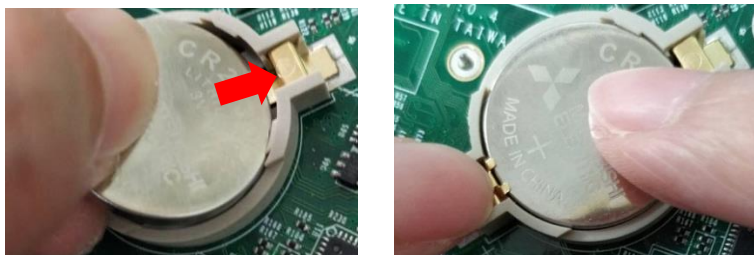

Step 6. Firmly insert the battery bracket.

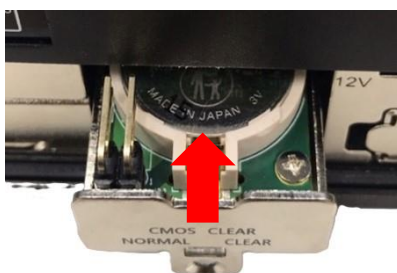

Step 7. Secure the bracket with a screw.



Step 8. Reinstall the maintenance zone cover plate and secure it with two screws.



3.12 Installing Wall Mount

The DX-1300 supports wall mounting when used with the wall mount kit.



Step 1. Secure the wall mount brackets to the bottom of the system using 8 screws (M5x6L) provided with the kit.



Step 2. Secure the system to the wall by using the bracket mounting holes.



3.13 Installing VESA Mount

The DX-1300 supports VESA mounting. The 75mm VESA standard uses screw holes in blue, while the 100mm VESA standard uses the screw holes in red.

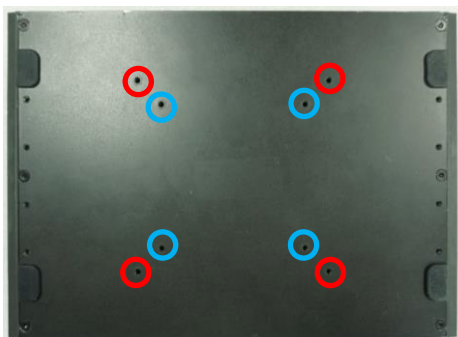

Step 1. Place the VESA stand on top of the system and align the holes on the stand with the holes on the bottom of the DX-1300. Secure the stand to the system with screws.



NOTE (NOTE)

The VESA mounting holes 3 mm deep at the back of the terminal are provided with 4 x M4-type blind fasteners to secure the VESA mounting plate. Please select a suitable screw length (L) based on the situation on-site.

(Les trous de fixation VESA, d'une profondeur de 3 mm, situés à l'arrière du terminal sont équipés de 4 fixations borgnes de type M4 pour la fixation de la plaque de montage VESA. Veuillez sélectionner une longueur de vis (L) appropriée en fonction des conditions sur site.)

3.14 Installing CMI Modules

3.14.1 CMI-10GLAN05-R10/UB1728-R10

Before using the CMI-10GLAN05 module, a BIOS setting must be configured. Navigate to **Advanced** > **PCH-IO Configuration** and change the [BTB_FH2 Mode Selection] or [BTB_FH3 Mode Selection] setting from [4x1] (default) to [1x4] to enable the module to function properly.

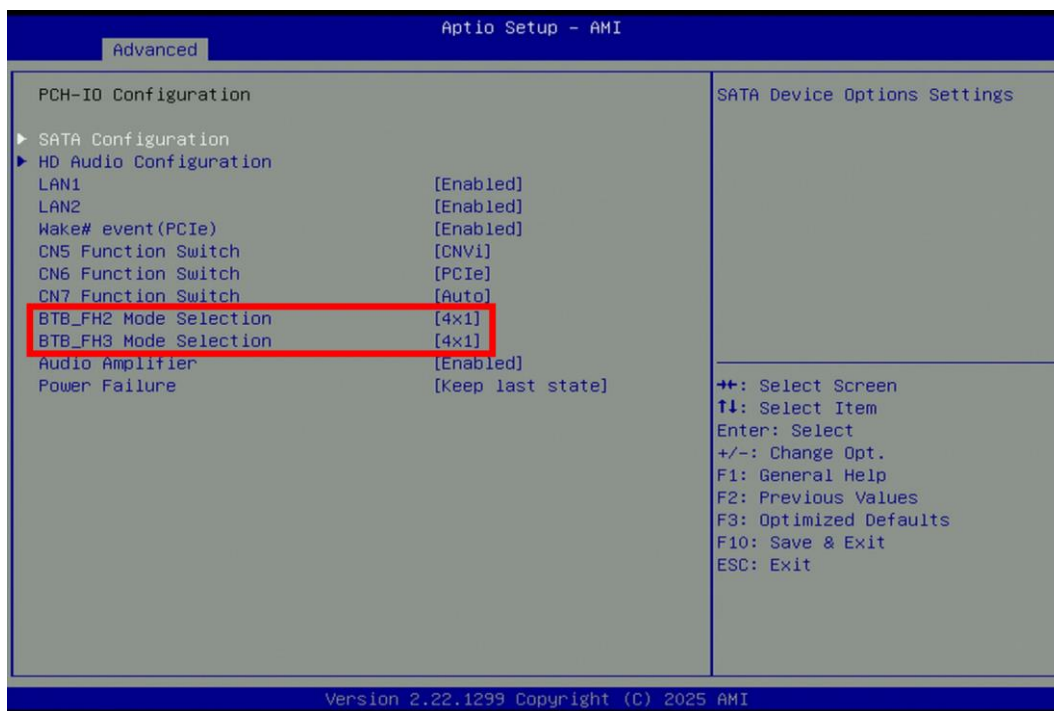

Step 1. Locate the chip on the CMI-10GLAN05-R10 module marked by the red square. Carefully apply the thermal pad to the chip.

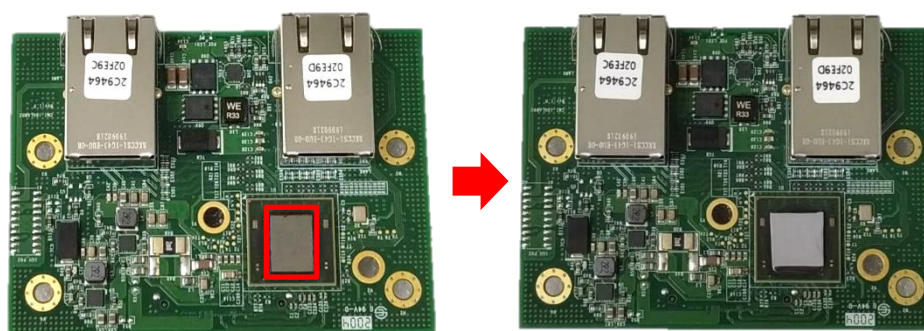

CAUTION
(ATTENTION)

Before putting on the thermal block (in the next step), please make sure the protective film on the Thermal Pad has been removed!
(Avant de mettre le bloc thermique (à l'étape suivante), veuillez vous assurer que le film protecteur sur le coussin thermique a été retiré!)

Step 2. Install the heatsink and flip the module over. Fasten the screw indicated below to secure the heatsink to the module.

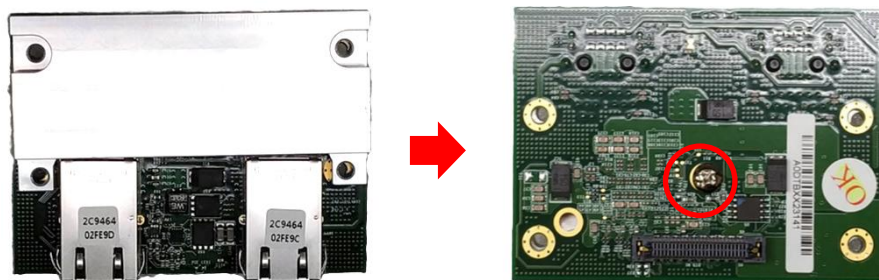

Step 3. Loosen screws on the front bezel to remove either cover plate 1 or 2.

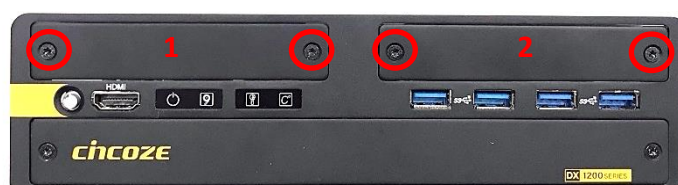

Step 4. Locate either CMI connector BTB_FH2 or BTB_FH3 on the top side of the system.

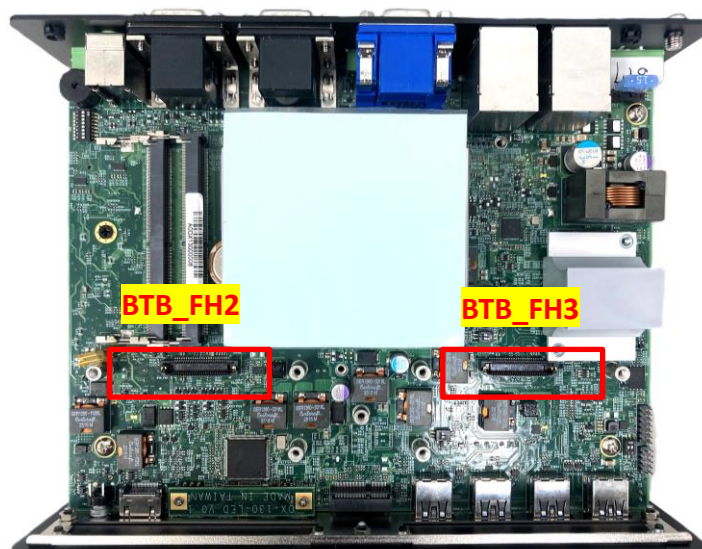

Step 5. Replace the indicated screw(s) with copper standoff(s) (M3x10).

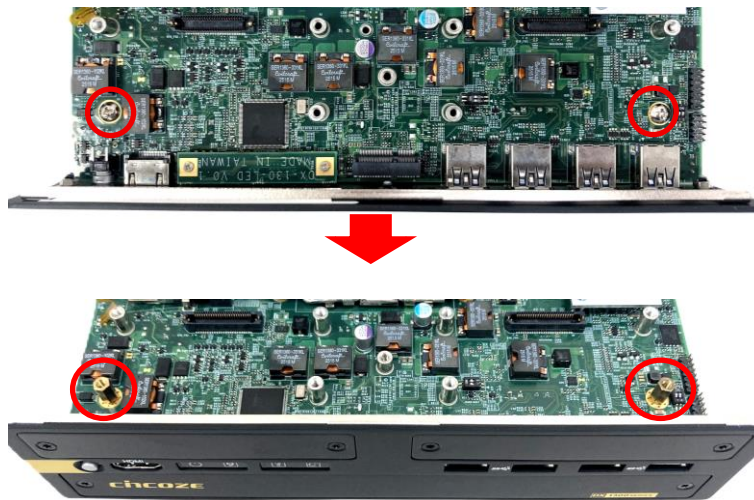

Step 6. Insert the CMI module firmly into the connector, then secure it with screws (M3x12).

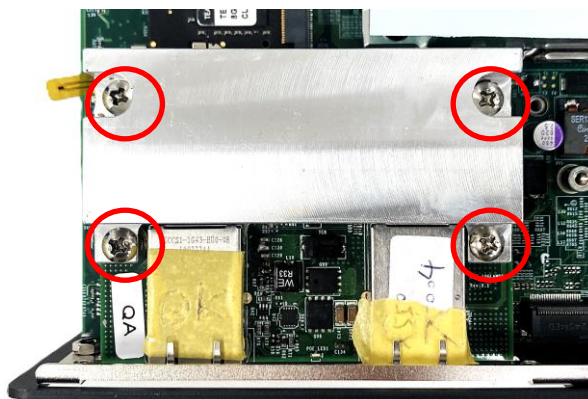

Step 7. Carefully apply the thermal pad onto the heatsink.



CAUTION
(ATTENTION)

Before assembling the system's chassis cover, please make sure the protective film on the Thermal Pad has been removed!

(Avant d'assembler le couvercle du châssis du système, assurez-vous que le film protecteur sur le coussin thermique a été retiré !d'alimentation CC au système.)

Step 8. Attach the I/O bracket and fasten the two screws to secure it to the front panel.



3.14.2 CMI-LAN01-R12/UB1712-R10

Step 1. Loosen screws on the front bezel to remove either cover plate 1 or 2.



Step 2. Locate either CMI connector BTB_FH2 or BTB_FH3 on the top side of the system.

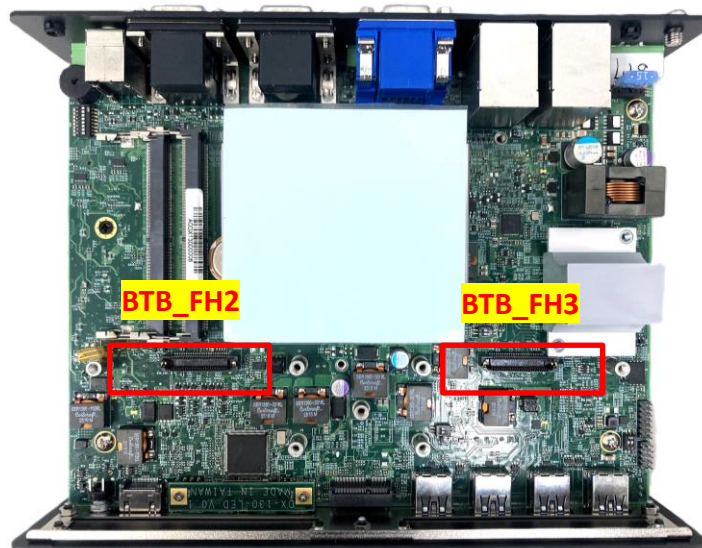

Step 3. Replace the indicated screw(s) with copper standoff(s) (M3x10).

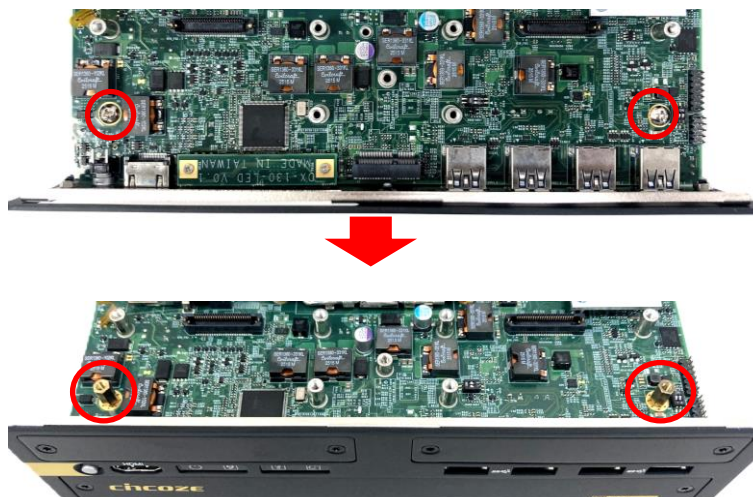

Step 4. Insert the CMI module firmly into the connector, then secure it with screws (M3x5).

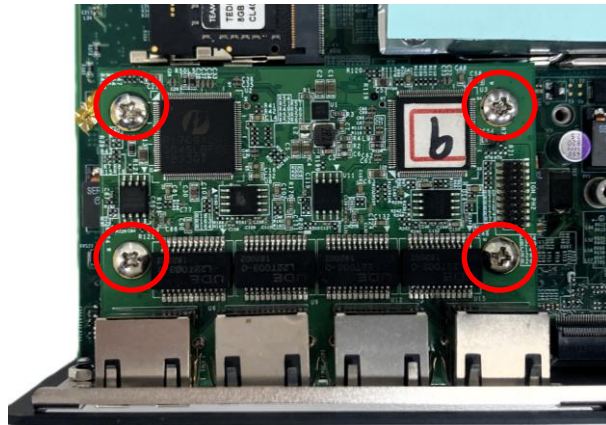

Step 5. Attach the I/O bracket and fasten the two screws to secure it to the front panel.



3.14.3 CMI-M12LAN01-R12/UB1710-R10

Step 1. Remove the nuts and O-rings on the respective M12 connectors.

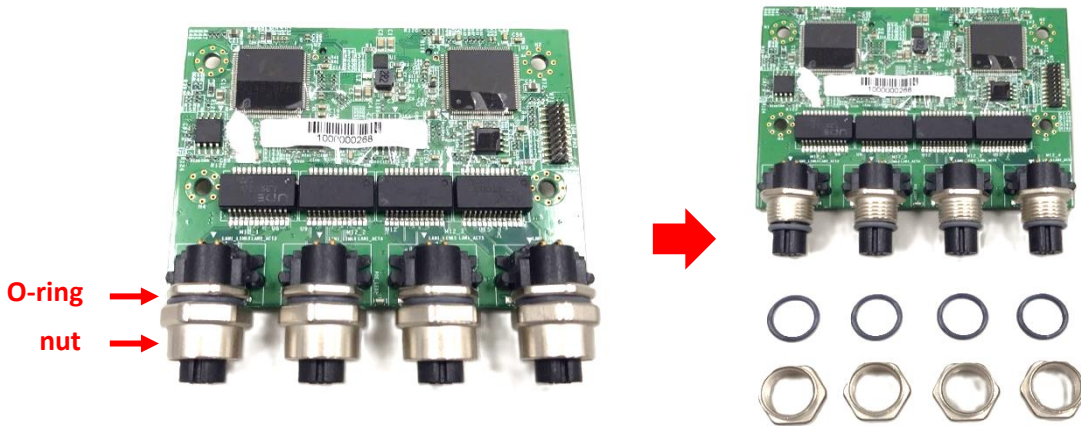

Step 2. Loosen screws on the front bezel to remove the cover plate 1 or 2.



Step 3. Locate the CMI connector(s) BTB_FH2 or BTB_FH3 on the top side of the system.

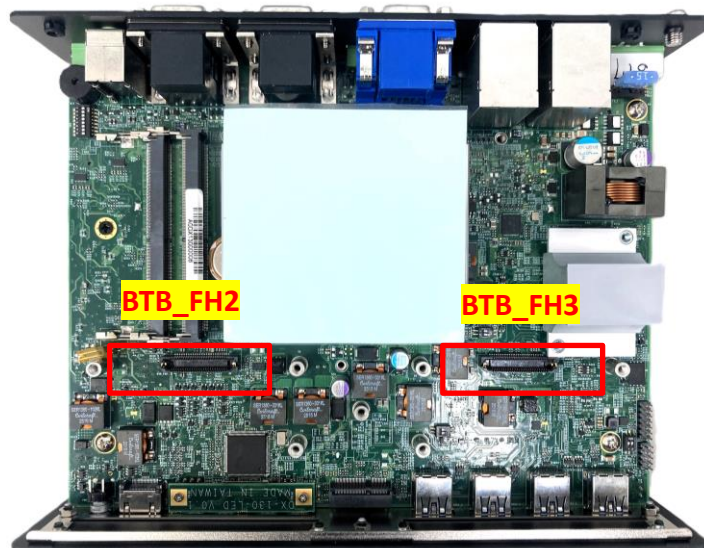

Step 4. Replace the indicated screw(s) with copper standoff(s) (M3x10).

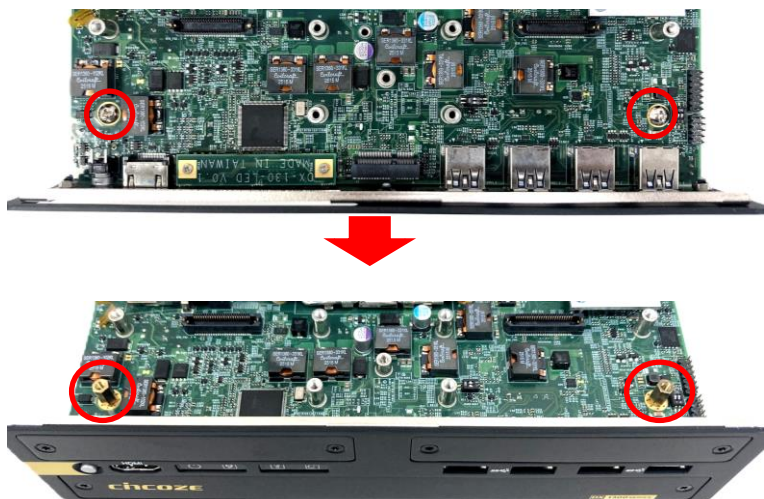

Step 5. Insert the CMI module firmly into the connector, then secure it with screws (M3x5).

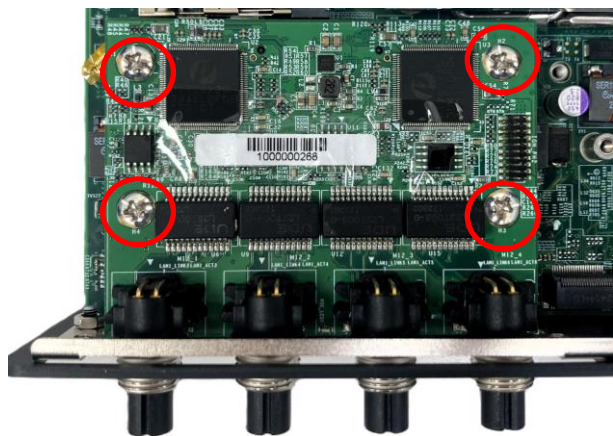

Step 6. Attach the I/O bracket and fasten the two screws to secure it to the system.



Step 7. Reinstall the 4 O-rings.



Step 8. Reinstall the 4 nuts.



3.14.4 CMI-XM12LAN01-R10/UB0930-R10

Step 1. Remove the hex washers, nuts, and O-rings on the respective M12 connectors.

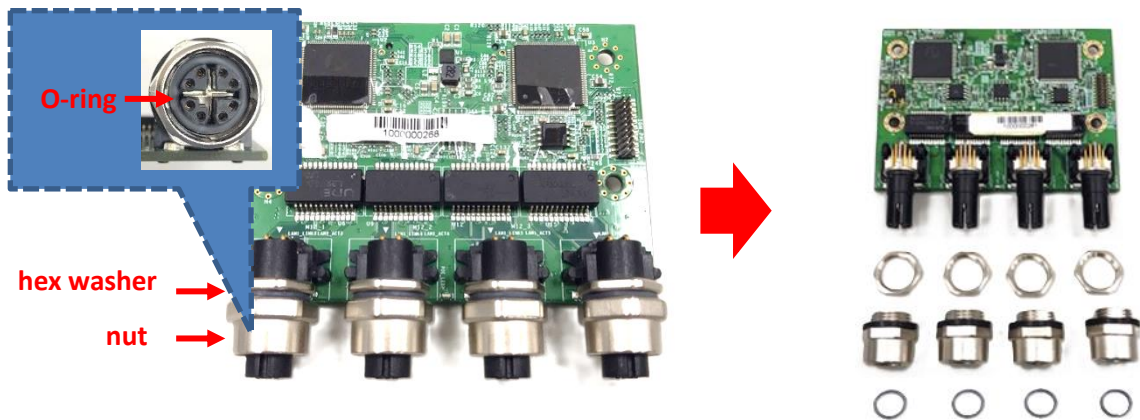

Step 2. Assemble the hex rings, M12 I/O bracket, and hex washers as indicated below: insert the hex rings through the M12 I/O bracket holes, then secure them with hex washers.

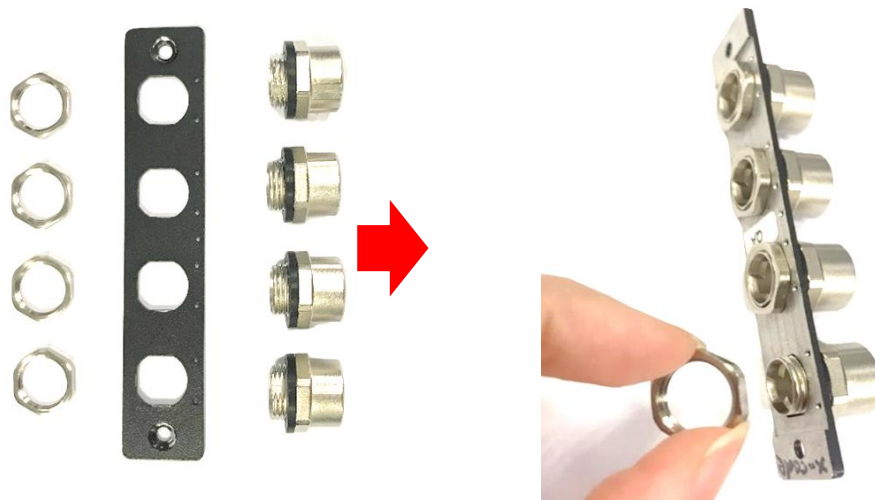

Step 3. Loosen screws on the front bezel to remove the cover plate 1 or 2.



Step 4. Locate the CMI connector(s) BTB_FH2 or BTB_FH3 on the top side of the system.

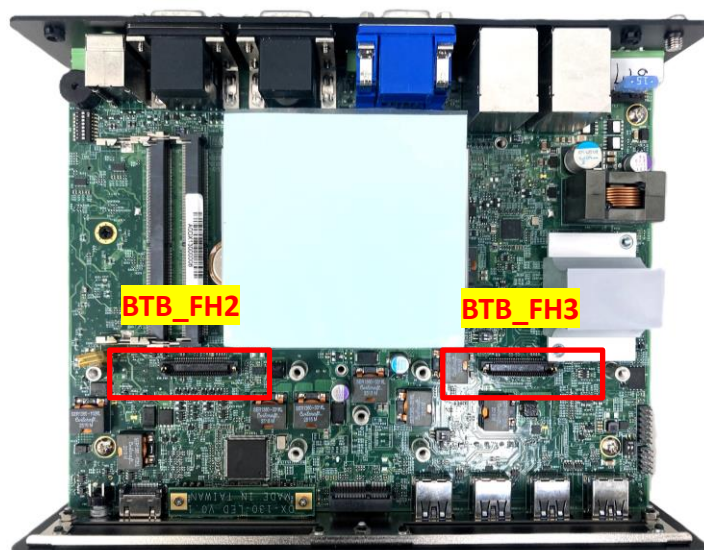

Step 5. Replace the indicated screw(s) with copper standoff(s) (M3x10).

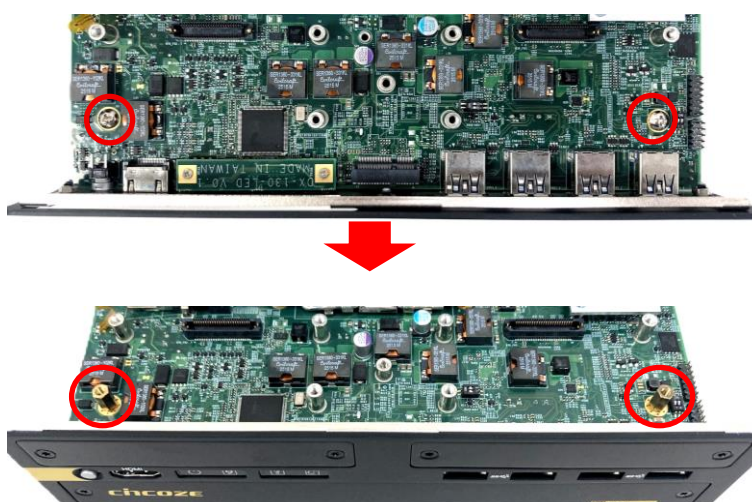

Step 6. Insert the CMI module firmly into the connector, then secure it with screws (M3x5).

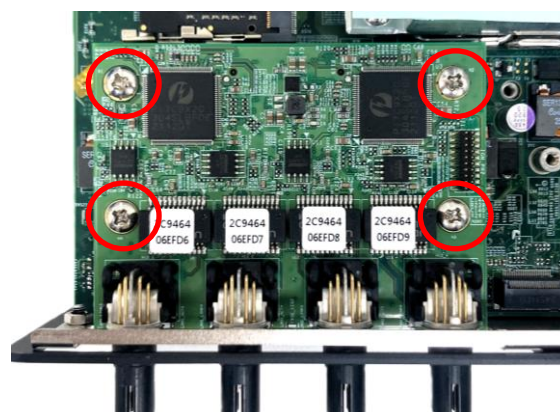

Step 7. Attach the I/O bracket and fasten the two screws to secure it to the system.



Step 8. Insert the O-rings into the XM12LAN ports. Tweezers are recommended.

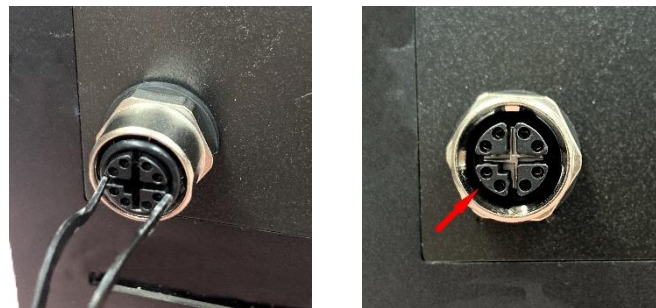

3.14.5 CMI-10GXM12LAN01-R10/UB1737-R10

Before using the CMI-10GLAN05 module, a BIOS setting must be configured. Navigate to **Advanced** > **PCH-IO Configuration** and change the **[BTB_FH2 Mode Selection]** or **[BTB_FH3 Mode Selection]** setting from **[4x1]** (default) to **[1x4]** to enable the module to function properly.

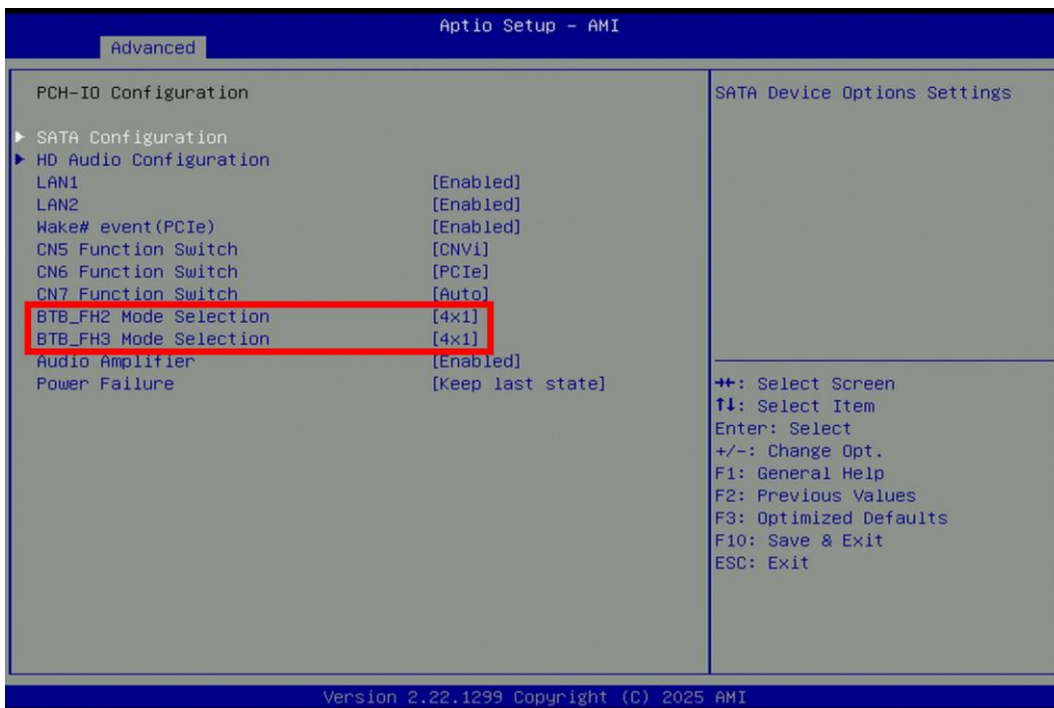

Step 1. Assemble the 10GXM12LAN bracket as indicated below: slot the hex rings through the XM12 I/O bracket and secure them from the inside with the hex nuts.

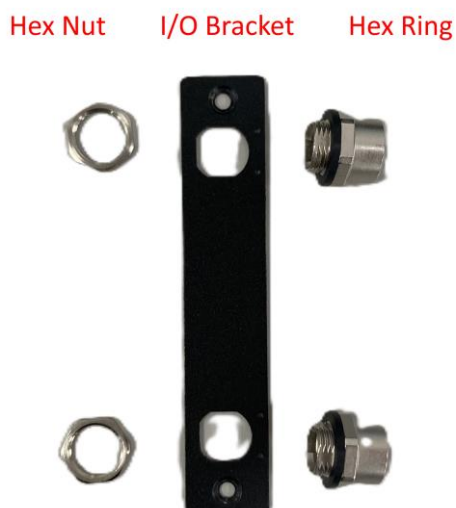

Step 2. Locate the chip on the CMI-10GXM12LAN module marked by the red square. Carefully apply the thermal pad to the chip.

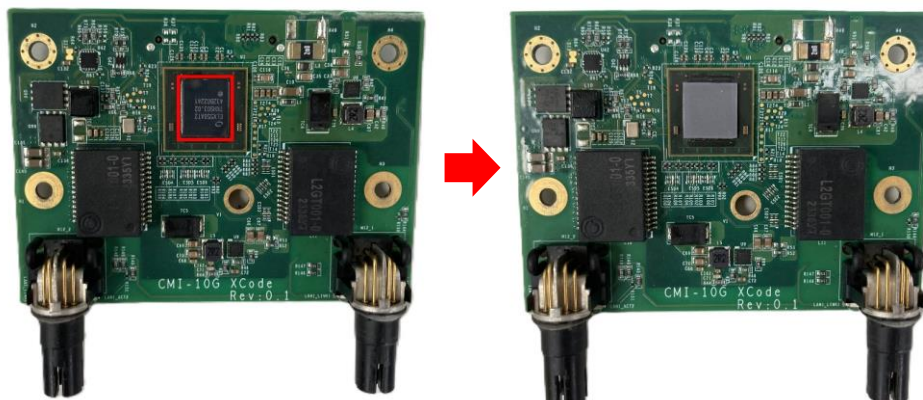

CAUTION
(ATTENTION)

Before installing the heatsink (in the next step), please make sure the protective films on both sides of the thermal pad have been removed!

(Avant d'installer le dissipateur thermique (à l'étape suivante), veuillez vous assurer que les films protecteurs des deux côtés du tampon thermique ont été retirés !)

Step 3. Install the heatsink and flip the module over. Fasten the screw indicated below to secure the heatsink to the module.

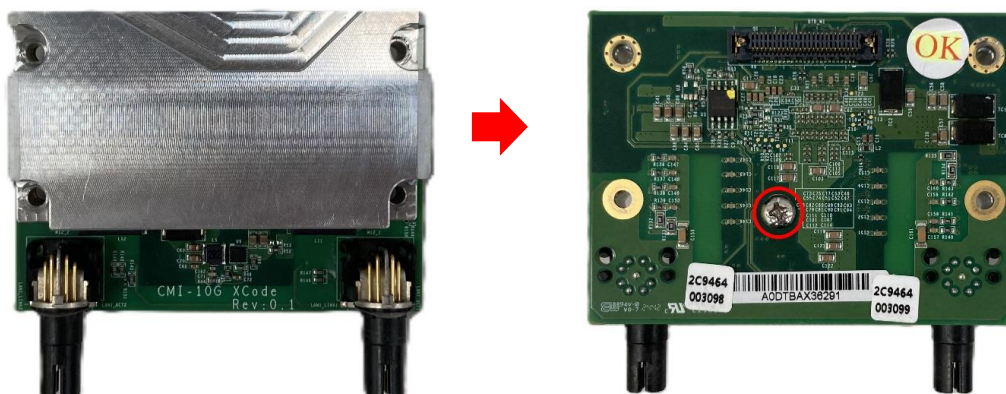

Step 4. Loosen screws on the front bezel to remove either cover plate 1 or 2.



Step 5. Locate either CMI connector BTB_FH2 or BTB_FH3 on the top side of the system.

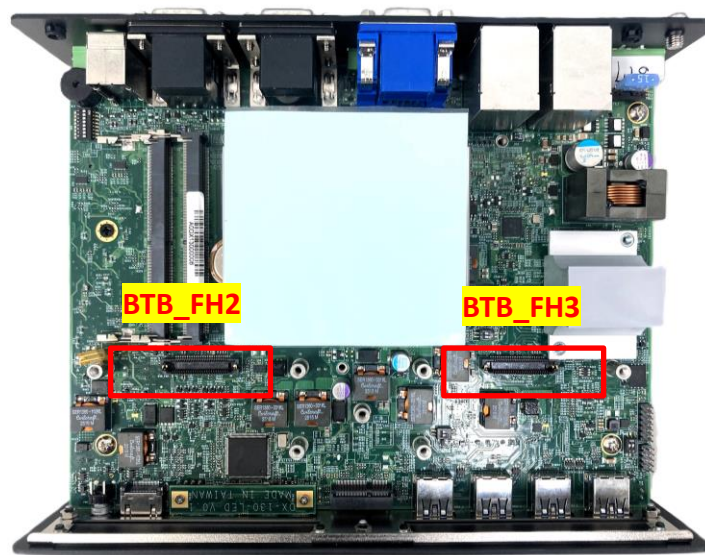

Step 6. Replace the indicated screw(s) with copper standoff(s) (M3x10).

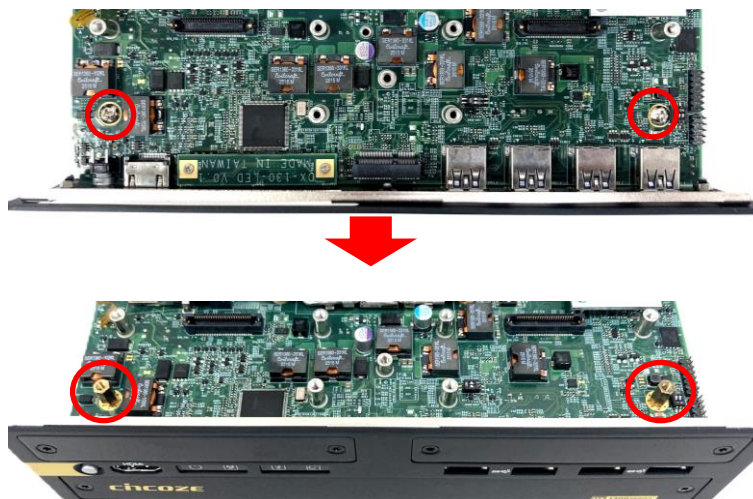

Step 7. Insert the CMI module vertically into either connector BTB_FH2 or BTB_FH3 until it is firmly seated, then secure it to the motherboard with 4 screws as indicated below.

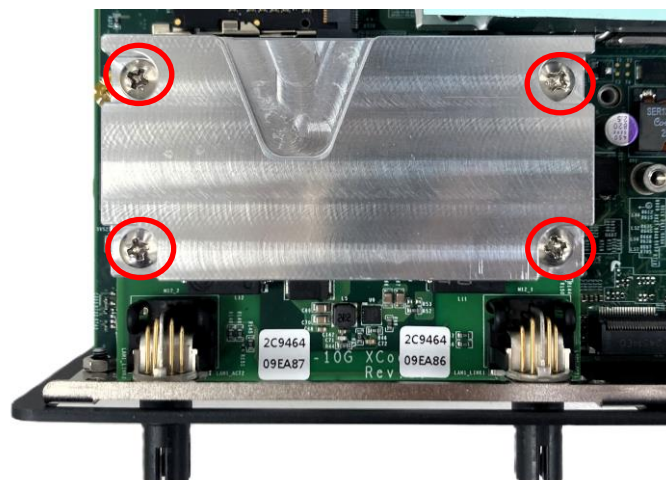

Step 8. Carefully apply a thermal pad to the heatsink.



CAUTION
(ATTENTION)

Before assembling the system, please make sure the protective films on both sides of the thermal pad have been removed!

(Avant d'assembler le système, veuillez vous assurer que les films protecteurs des deux côtés du pad thermique ont été retirés !)

Step 9. Attach the I/O bracket and fasten the two screws to secure it to the system.



Step 10. Insert the O-rings into the XM12LAN ports. Tweezers are recommended.

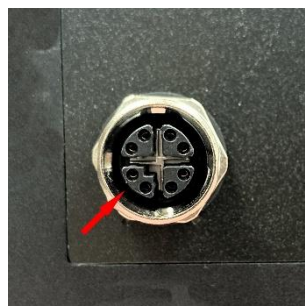

3.14.6 CMI-2P5GLAN01-R10/UB1712-R10

Step 1. Loosen screws on the front bezel to remove either cover plate 1 or 2.



Step 2. Locate either CMI connector BTB_FH2 or BTB_FH3 on the top side of the system.

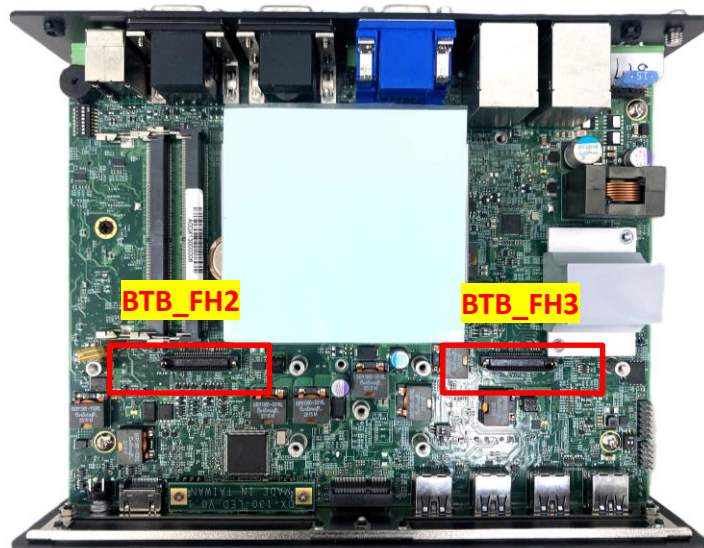

Step 3. Replace the indicated screw(s) with copper standoff(s) (M3x10).

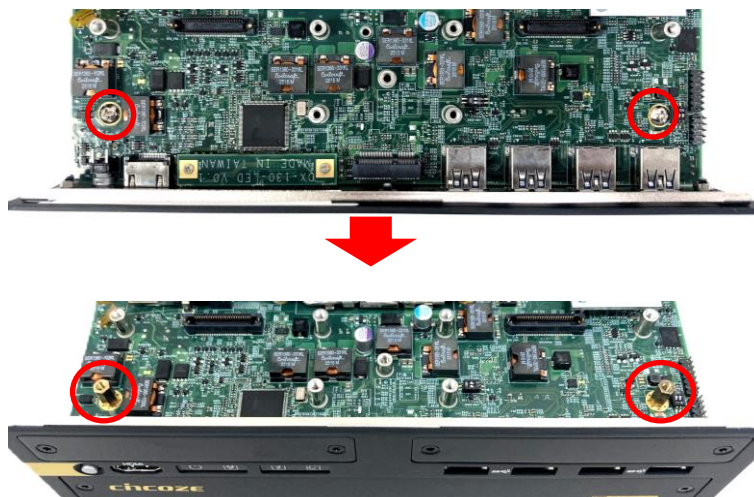

Step 4. Locate the 5 chips on the CMI-2P5GLAN module indicated by the red squares below. Carefully apply thermal pads to each chip.

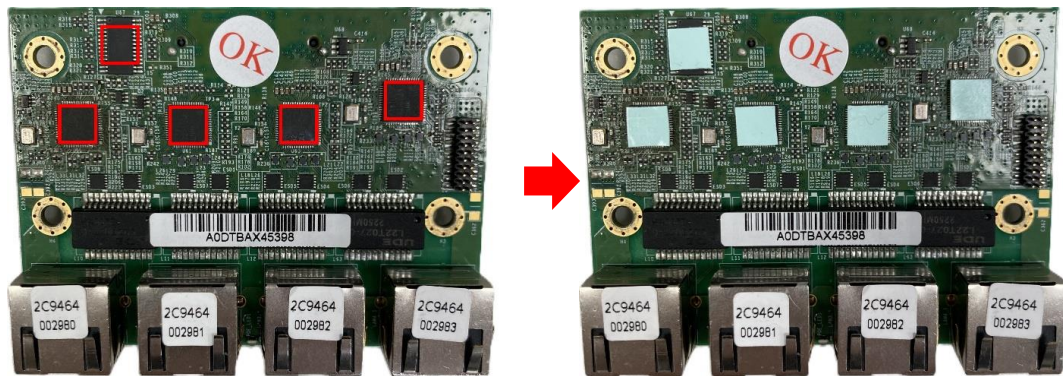

Step 5. Insert the CMI module vertically into either BTB_FH1 or BTB_FH3 until it is firmly seated.

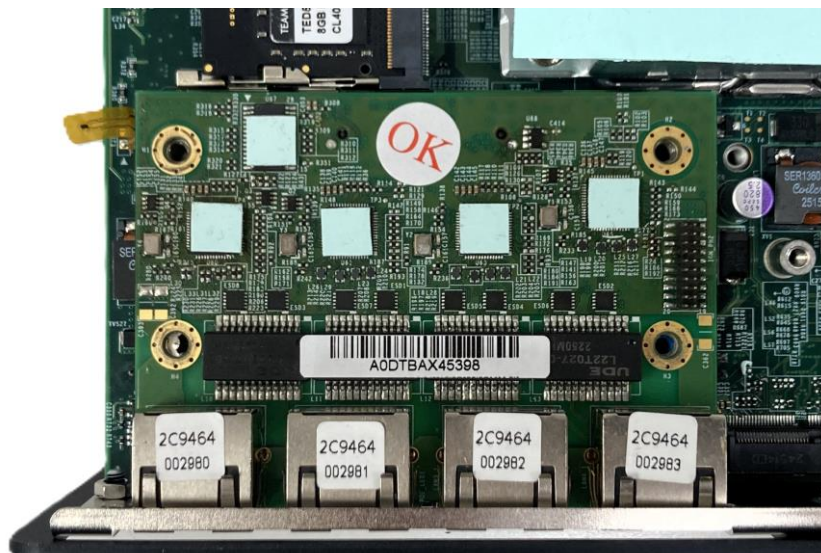

CAUTION
(ATTENTION)

Before installing the heatsink (in the next step), please make sure the protective films on both sides of the thermal pad have been removed!

(Avant d'installer le dissipateur thermique (à l'étape suivante), veuillez vous assurer que les films protecteurs des deux côtés du tampon thermique ont été retirés !)

Step 6. Align the heatsink protrusions with the chip pads on the CMI module and place it onto the module.

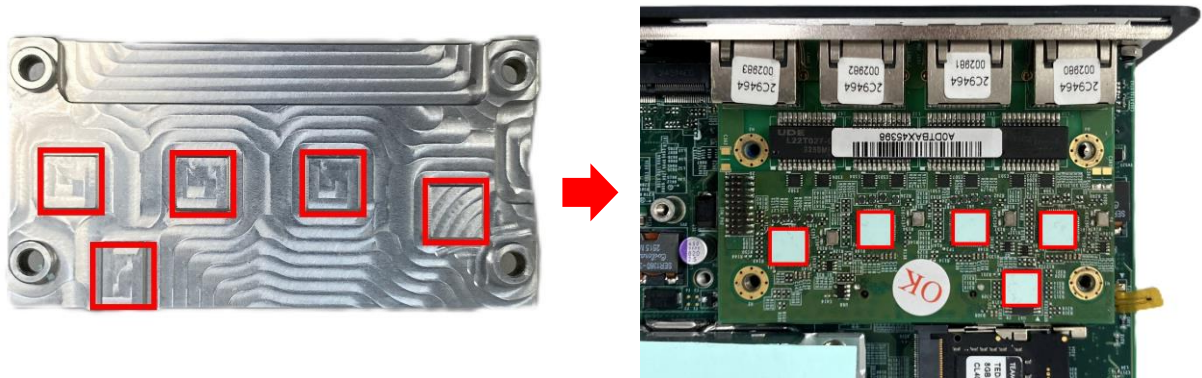

Step 7. Secure the CMI module to the motherboard using 4 screws as indicated below.

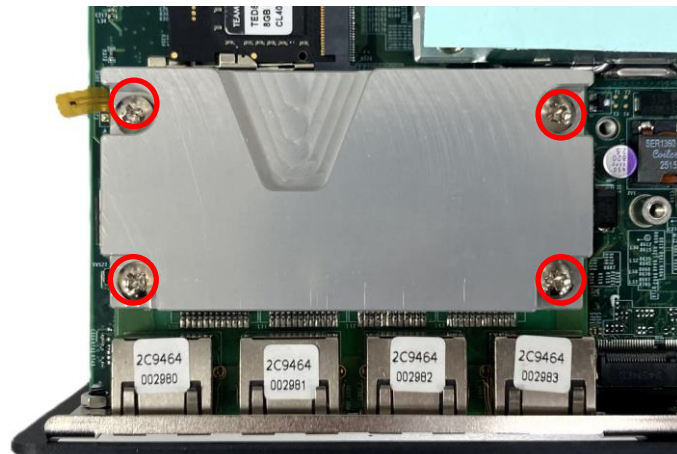

Step 8. Carefully apply a thermal pad to the heatsink.

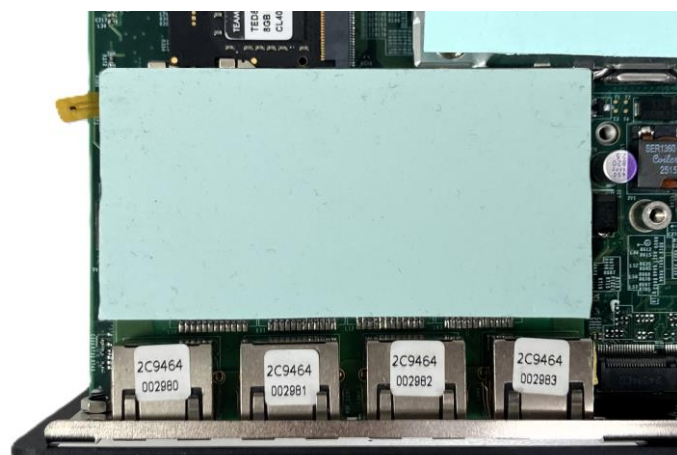



CAUTION
(ATTENTION)

Before assembling the system, please make sure the protective films on both sides of the thermal pad have been removed!
(Avant d'assembler le système, veuillez vous assurer que les films protecteurs des deux côtés du pad thermique ont été retirés !)

Step 9. Attach the I/O bracket and fasten the two screws to secure it to the front panel.



3.14.7 CMI-COM01/UB1303

Step 1. Remove the screws on the rear panel to remove the cover plate 4.

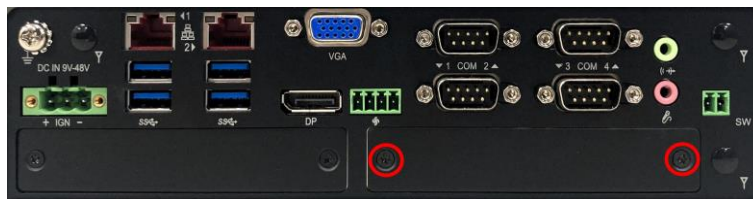

Step 2. Locate CMI connector BTB_FH1 on the bottom of the system.

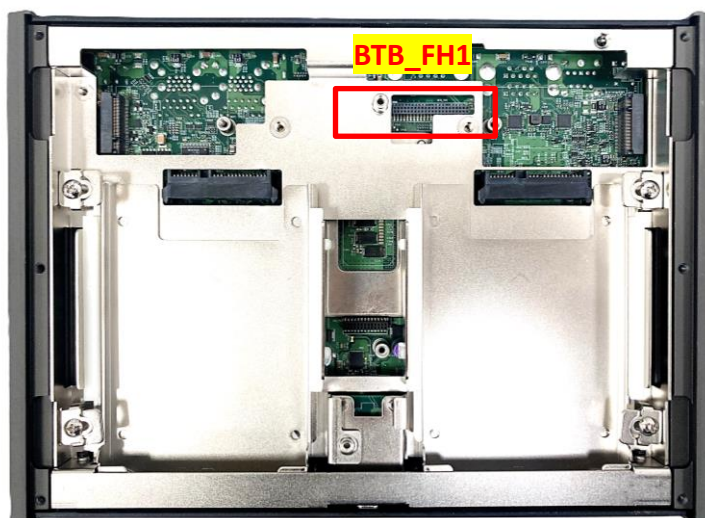

Step 3. Insert the module at a slight angle, then seat the CMI module into the connector BTB_FH1. Use a torque screwdriver (manual type with adjustable torque setting; see the example below), and set the torque to 2 kgf·cm. Secure the module to the system with screws (screw 1, top right: M3x5, countersunk; screw 2, bottom left: M3x5, mushroom).

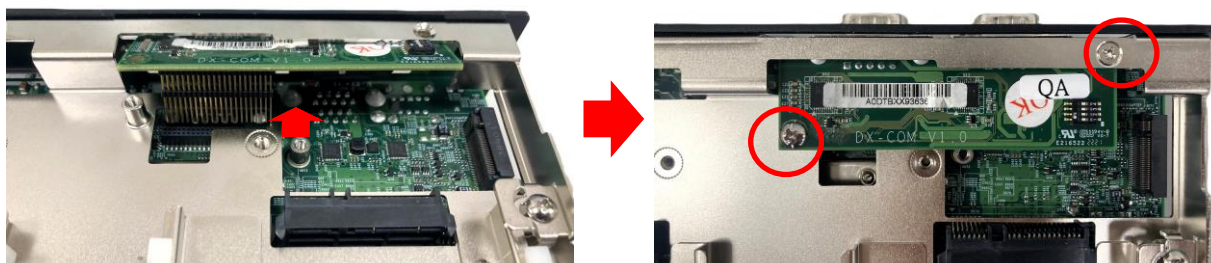



**CAUTION
(ATTENTION)**

Failure to apply the specified torque may result in module damage, system frame damage, or both.
(La non-application du couple spécifié peut entraîner des dommages au module, des dommages au châssis du système, ou les deux.)

Step 4. Attach the I/O bracket, then fasten 2 screws and 4 D-Sub jack screws to secure it.



3.14.8 CMI-DIO01/UB1318

Step 1. Remove the screws on the rear panel to remove the cover plate 4.



Step 2. Locate CMI connector BTB_FH1 on the bottom of the system.

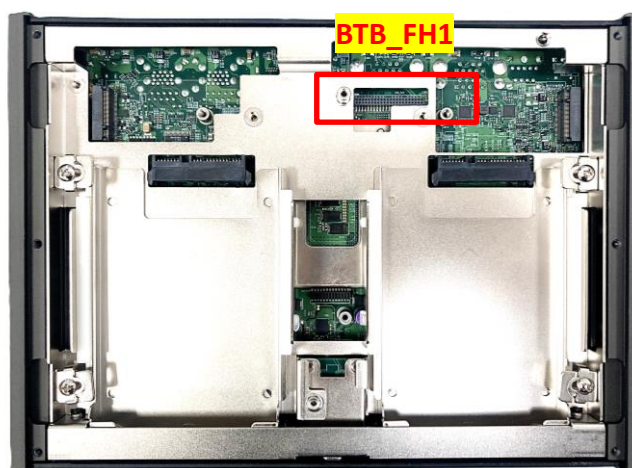

Step 3. Insert the module at a slight angle, then seat the CMI module into the connector BTB_FH1. Use a torque screwdriver (manual type with adjustable torque setting; see the example below), and set the torque to 2 kgf·cm. Secure the module to the system with screws (screw 1, top right: M3x5, countersunk; screw 2, bottom left: M3x5, mushroom).

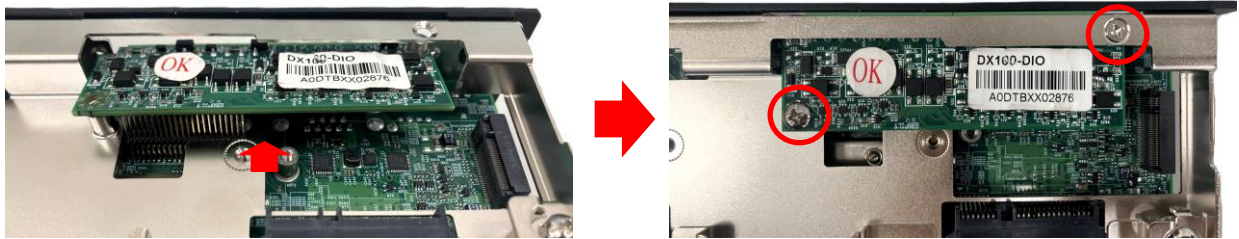

CAUTION
(ATTENTION)

Failure to apply the specified torque may result in module damage, system frame damage, or both.

(La non-application du couple spécifié peut entraîner des dommages au module, des dommages au châssis du système, ou les deux.)

Step 4. Attach the I/O bracket, and fasten 2 screws to fix it.



3.15 Installing CFM Modules

3.15.1 CFM-PoE01

This module can be installed onto the CMI-LAN01, CMI-M12LAN01, or CMI-XM12LAN01 module. When using the CMI-LAN01-R12 module, shading tape must be applied to the area indicated by the red box. Do not block the PoE LED.

This step can be skipped when using the CMI-M12LAN01 module.

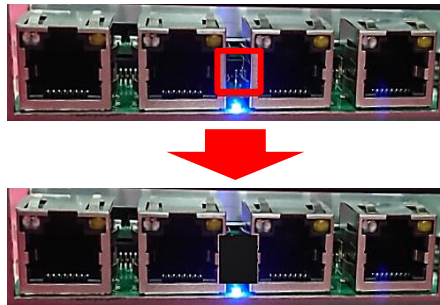

The section uses the CMI-M12LAN01 module as an example. Please follow the installation steps 1 to 4 in section 3.14.3 in advance.

Step 1. Fasten four copper standoffs onto the CMI-LAN module.



Step 2. Insert the CFM-PoE01 module onto the connector on the CMI-LAN module until it rests on top of the standoffs.



Step 3. Flip the CFM-PoE1 heatsink upside down and locate the two areas marked by red rectangles. Carefully apply thermal pads to these two areas.

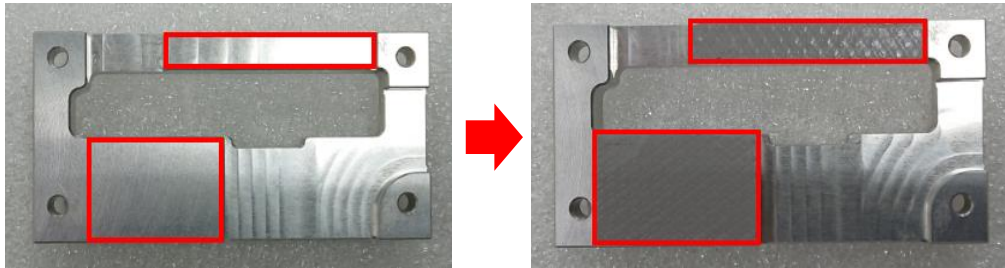

CAUTION
(ATTENTION)

Before putting on the thermal block (in the next step), please make sure the protective film on the Thermal Pad has been removed!
(Avant de mettre le bloc thermique (à l'étape suivante), veuillez vous assurer que le film protecteur sur le coussin thermique a été retiré!)

Step 4. Install the heatsink onto the CFM-PoE1 module and secure it to the CMI module with 4 screws as indicated below.



Step 5. Carefully apply a thermal pad to the heatsink, then continue with step 5 in section 3.14.3.

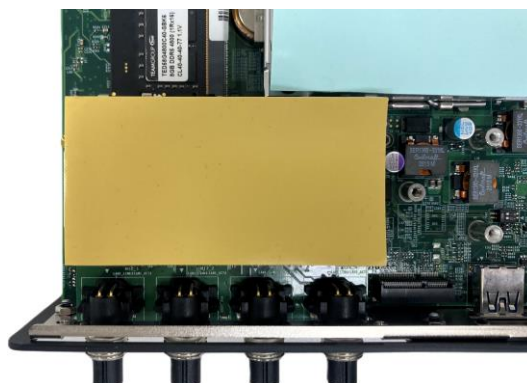

CAUTION
(ATTENTION)

The yellow surface is part of the thermal pad. Do not tear it off as it would affect the thermal conductivity.
(La surface jaune fait partie du coussin thermique. Ne l'arrachez pas car cela affecterait la conductivité thermique.)

3.15.2 CFM-IGN01

Step 1. Locate the IGN connector on the bottom side of the system.

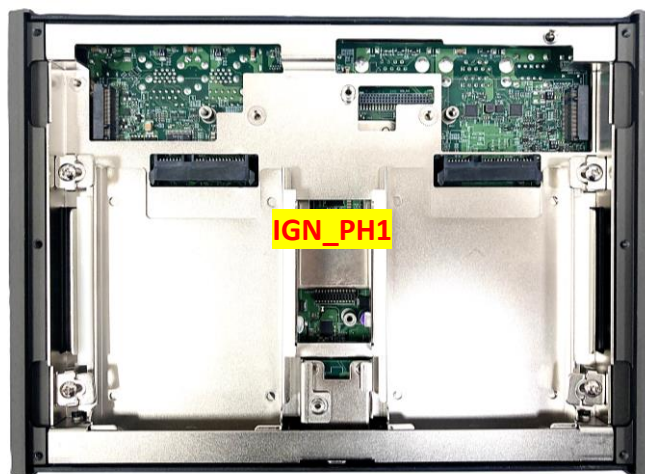

Step 2. Fasten 1 copper pillar (M3x9) before inserting the IGN module.



Step 3. Insert the IGN module vertically into the female connector on the system's mainboard, and secure it with two screws.



3.15.3 CFM-TPM02

A BIOS setting must be configured before this module can be installed. Press [Del] to enter BIOS, then navigate to **Advanced > PCH-FW > TPM Device Selection** and change the setting from **PTT** (default) to **dTPM**.

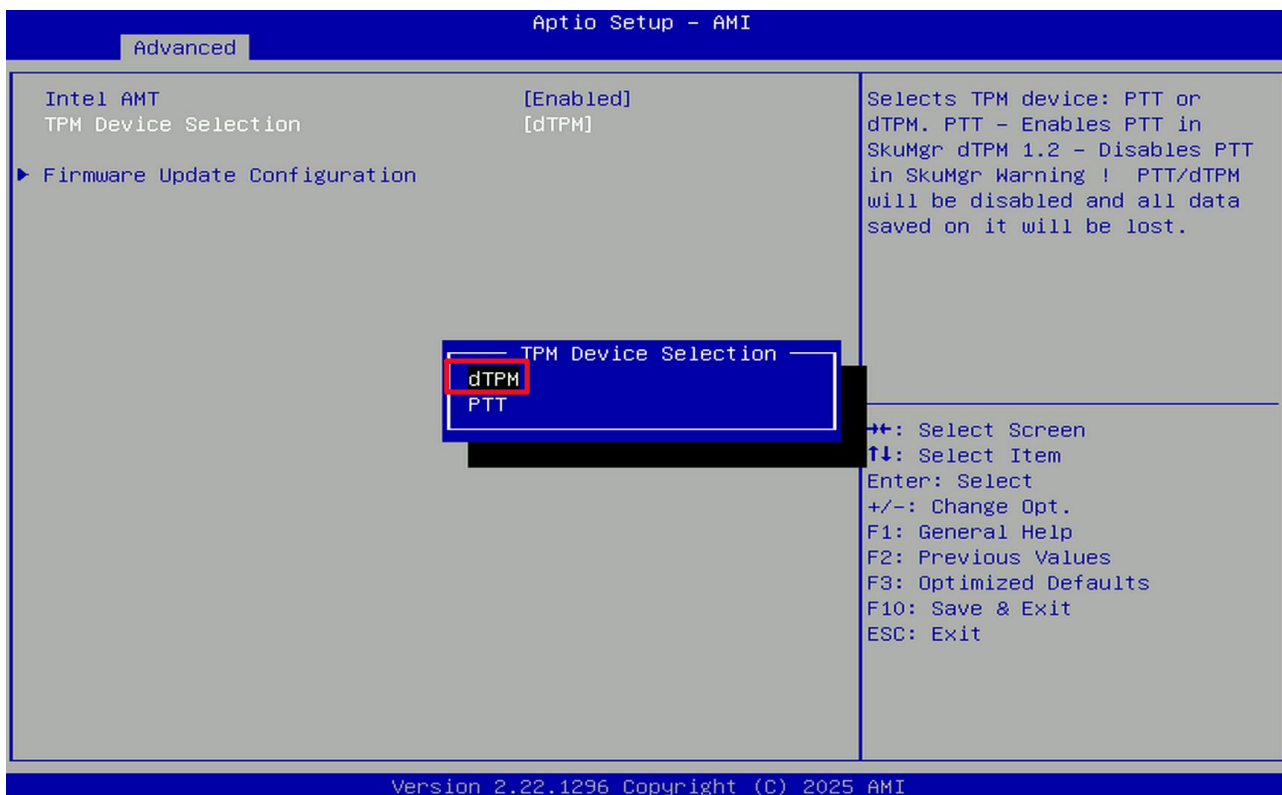

Step 1. Locate the two BTB_FH2 standoffis indicated in the picture below.

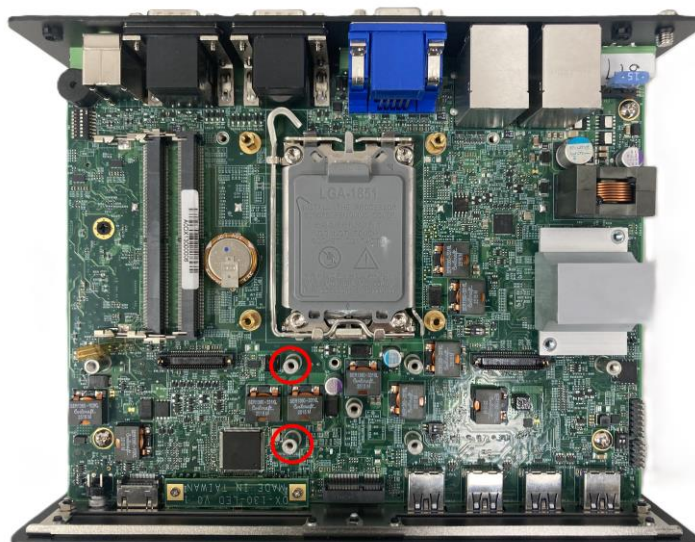

Step 2. Secure the TPM board onto the system using two screws.

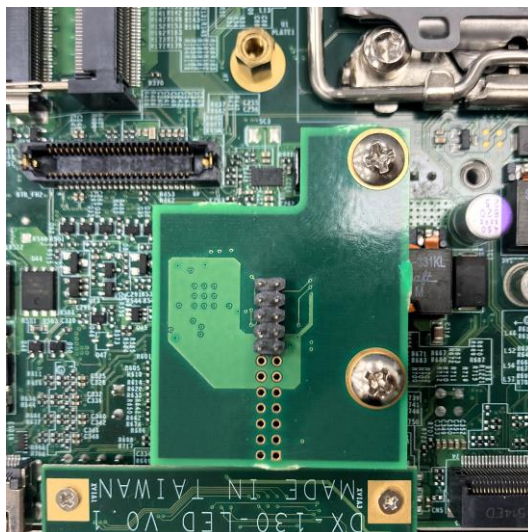

Step 3. Connect the TPM cable to the TPM board. The white dot indicates Pin 1.

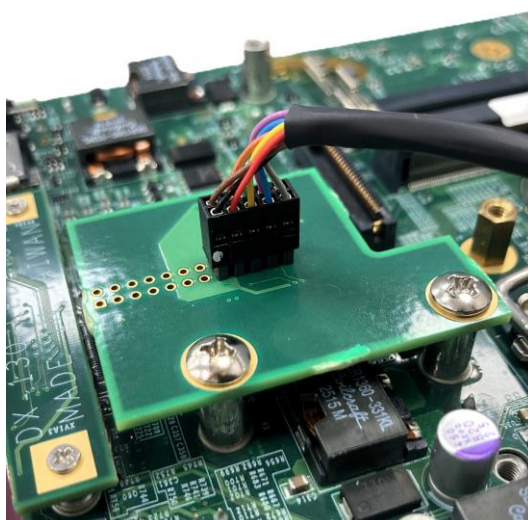

Step 4. Connect the other end of the TPM cable to the JP1 connector on the motherboard. The white dot indicates Pin 1.



3.16 SIDE-DX

The DX-1300 can be side-mounted when used with the optional Side Mount.



Step 1. Locate the mounting holes at the bottom of the system. Fasten the 8 screws (M3x5L*4pcs, M4x5L*4pcs) as indicated below to secure the side mount bracket to the system.

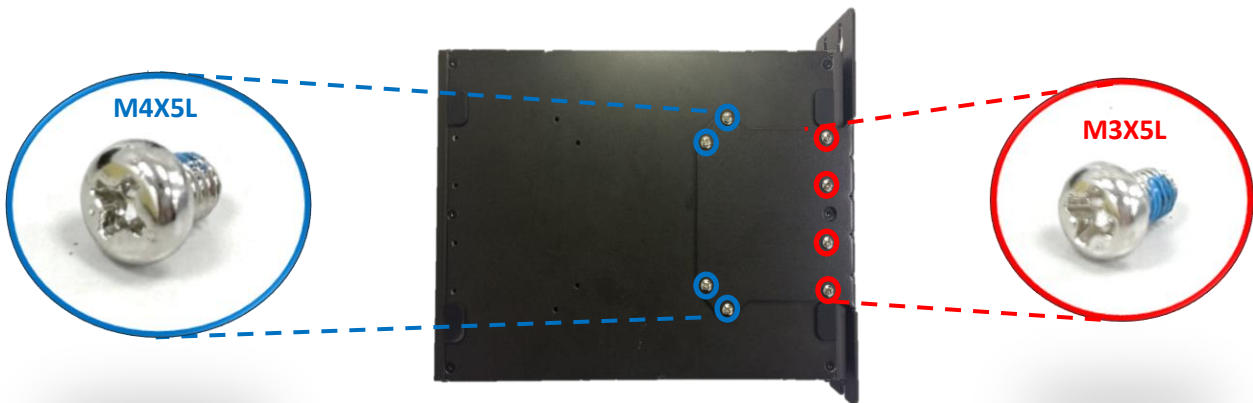

Step 2. Secure the system to the wall by using the bracket mounting holes.



3.17 DIN01

The DX-1300 can be mounted onto a DIN-Rail with the optional DIN-Rail Mount Kit.

Before beginning, refer to chapter 3.12 to install the wall mount bracket on both sides of the system.

Step 1. Secure each DIN rail mounting clip onto each side of the wall mount brackets with 2 screws (T3x10.5).



Step 2. Snap the system onto the DIN rail using the mounting clips.



3.18 FAN-EX101

Step 1. Prepare an external fan. Loosen but do not remove the 2 screws on the mounting bracket.



Step 2. Slide the nuts of the mount bracket screws into the middle groove of the top cover as indicated below.





Step 3. Move the fan to the center of the top cover and tighten the 2 screws to secure it as indicated below.



Step 4. Connect the fan cable to the external fan power connector on the rear panel.





Chapter 4

BIOS Setup

4.1 BIOS Introduction

The BIOS (Basic Input/ Output System) is a program stored on the motherboard's flash memory. When the computer is powered on, the BIOS will activate. The BIOS first runs an auto-diagnostic test called POST (Power On Self-Test), which detects and configures all hardware.

BIOS Setup

Setup can be accessed by pressing immediately after powering on the computer while the startup message is shown on the screen. If the message disappears before you can enter your keyboard input, you can restart the system to try again by pressing <Ctrl> + <Alt> + simultaneously.

Control Keys	
<←> <→>	Move to select screen
<↑> <↓>	Move to select item
<Esc>	Quit the BIOS Setup
<Enter>	Select item
<Page Up/+>	Increases the numeric value or makes changes
<Page Down/->	Decreases the numeric value or makes changes
<Tab>	Select setup fields
<F1>	General help
<F2>	Previous value
<F3>	Load Optimized defaults
<F10>	Save configuration and Exit

Main Menu

The main menu lists the setup functions you can change. You can use the arrow keys (↑↓) to select different items and fields. The description of the highlighted function is displayed at the bottom of the screen.

Sub-Menu

If a right pointer symbol is present to the left of a particular field, this field contains a sub-menu. A sub-menu contains additional options for a given field. You can use the arrow keys (↑↓) to highlight the field and press <Enter> to enter the sub-menu. Once inside, you can use the same keys to enter values and move from field to field. If you want to exit the sub-menu, press <Esc>.

4.2 Main Setup

After pressing to enter BIOS, the Main Menu will appear on the screen (see below). This manual is based on BIOS 0.0.01.001.

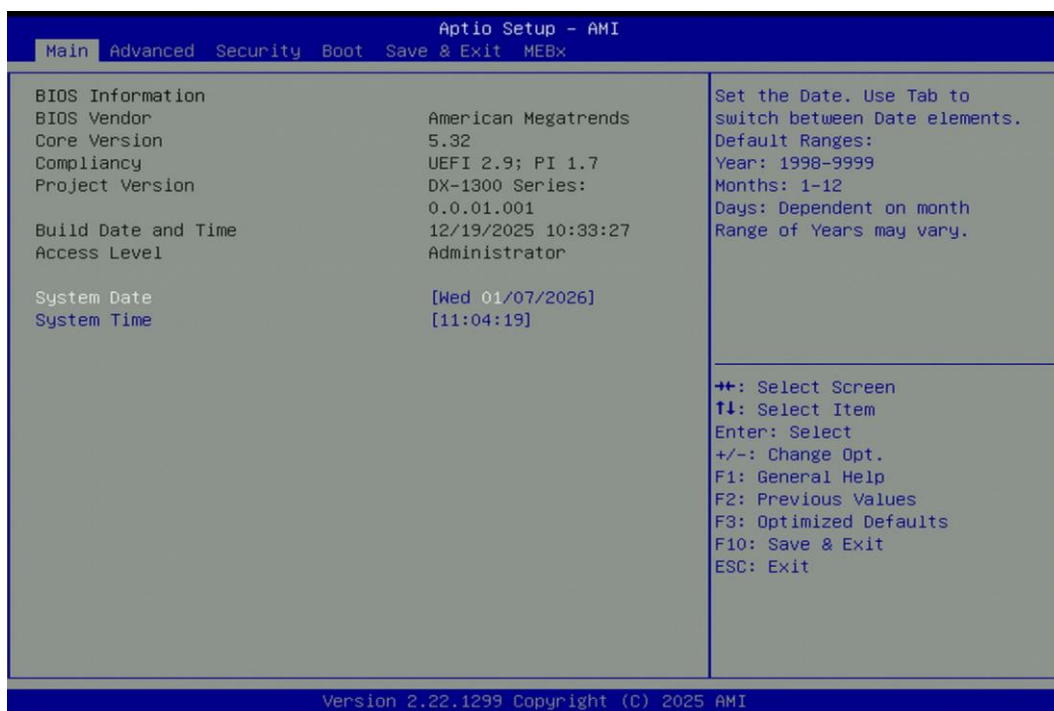

■ System Date

Set the date. Use <Tab> to switch between date elements.

■ System Time

Set the time. Use <Tab> to switch between time elements.

4.3 Advanced Setup

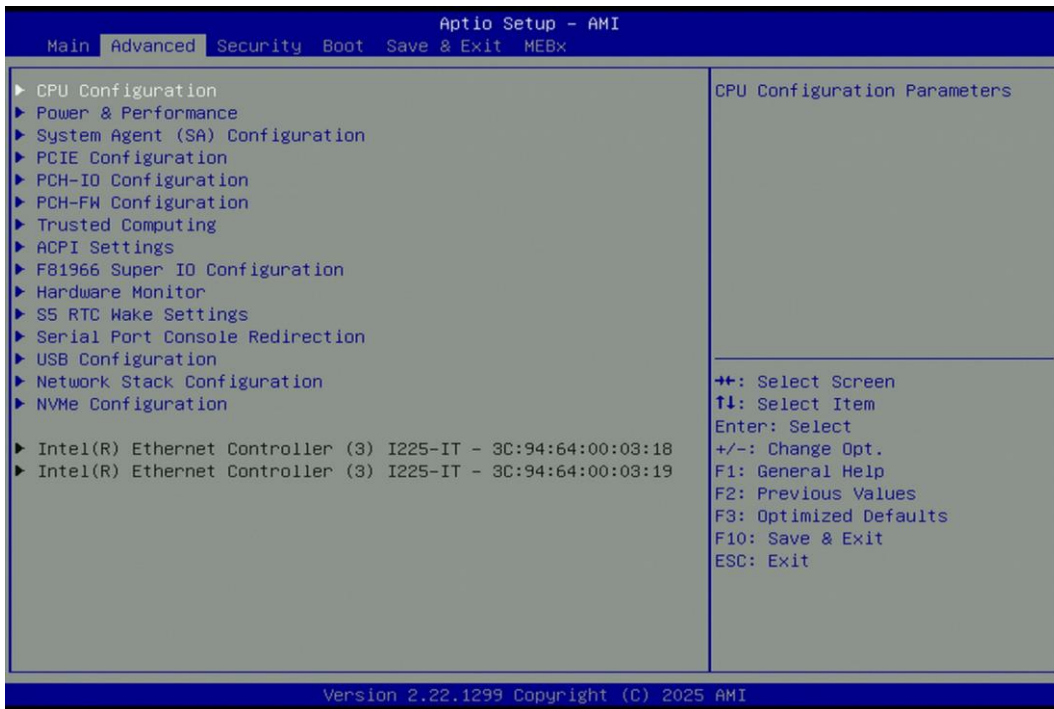

4.3.1 CPU Configuration

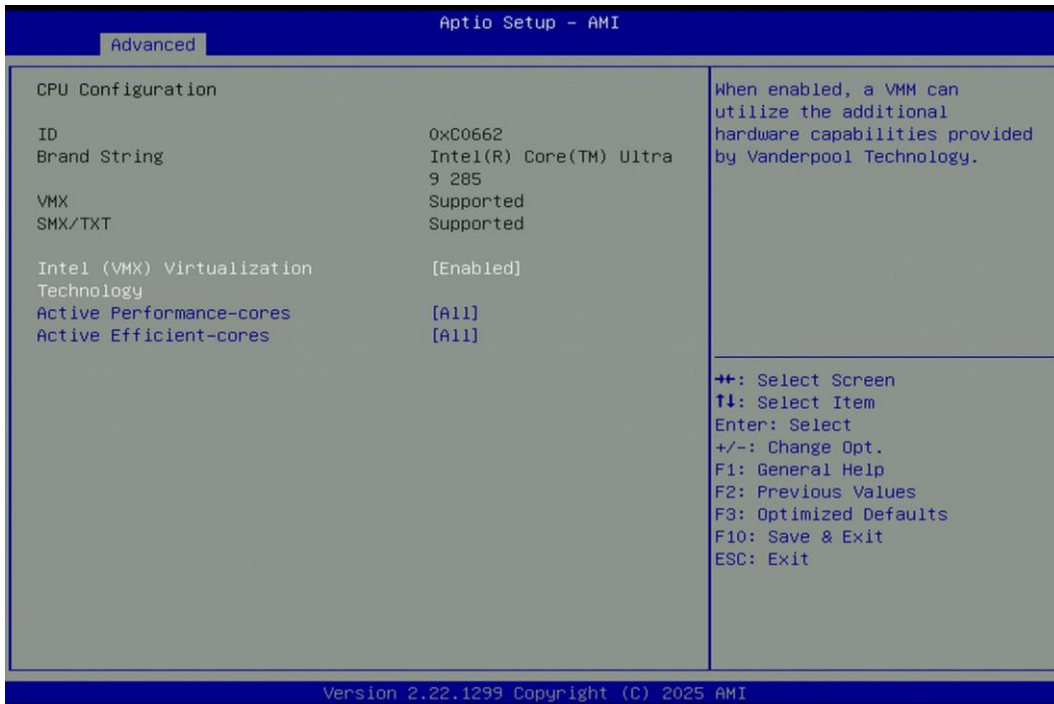

■ Intel (VMX) Virtualization Technology [Enabled]

Enables or disables Intel® Virtualization Technology. Virtualization enhanced by Intel® Virtualization Technology will allow a platform to run multiple operating systems and applications in independent partitions. With virtualization, one computer system can function as multiple virtual systems.

■ Active Performance-cores [All]

Allows users to choose the number of active performance cores. The options may change depending on the installed CPU.

Configuration options: [1] [2] [3] [4] [5] [6] [7] [All]

■ Active Efficient-cores [All]

Allows users to choose the number of active efficient cores. The options may change depending on the installed CPU.

Configuration options: [0] [1] [2] [3] [4] [5] [6] [7] [8] [9] [10] [11] [12] [13] [14] [15] [All]

4.3.2 Power & Performance

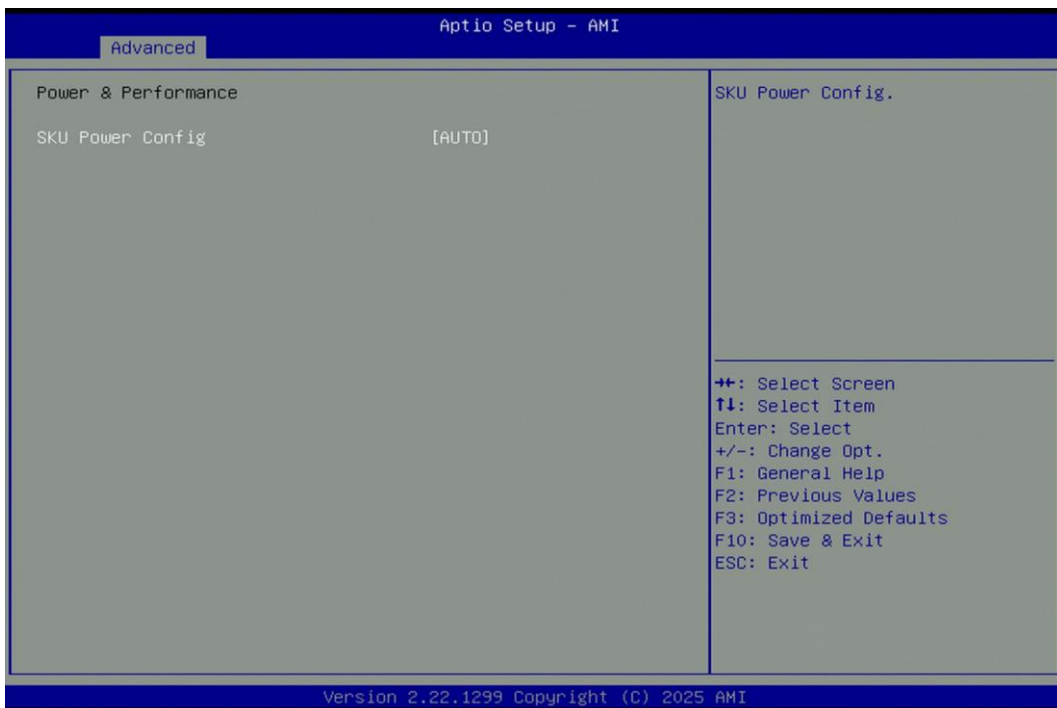

■ SKU Power Config [Auto]

Allows users to choose the upper limit of CPU power.

Configuration options: [Auto] [35W]

4.3.3 System Agent (SA) Configuration

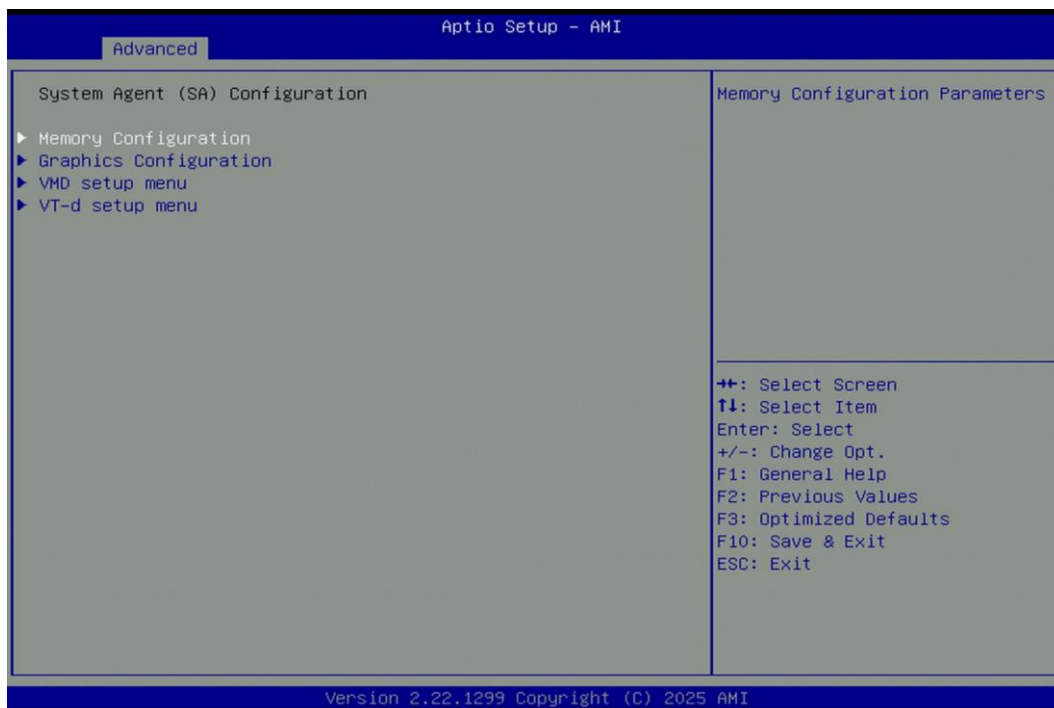

■ Memory Configuration

This item displays details of the memory installed in the system.

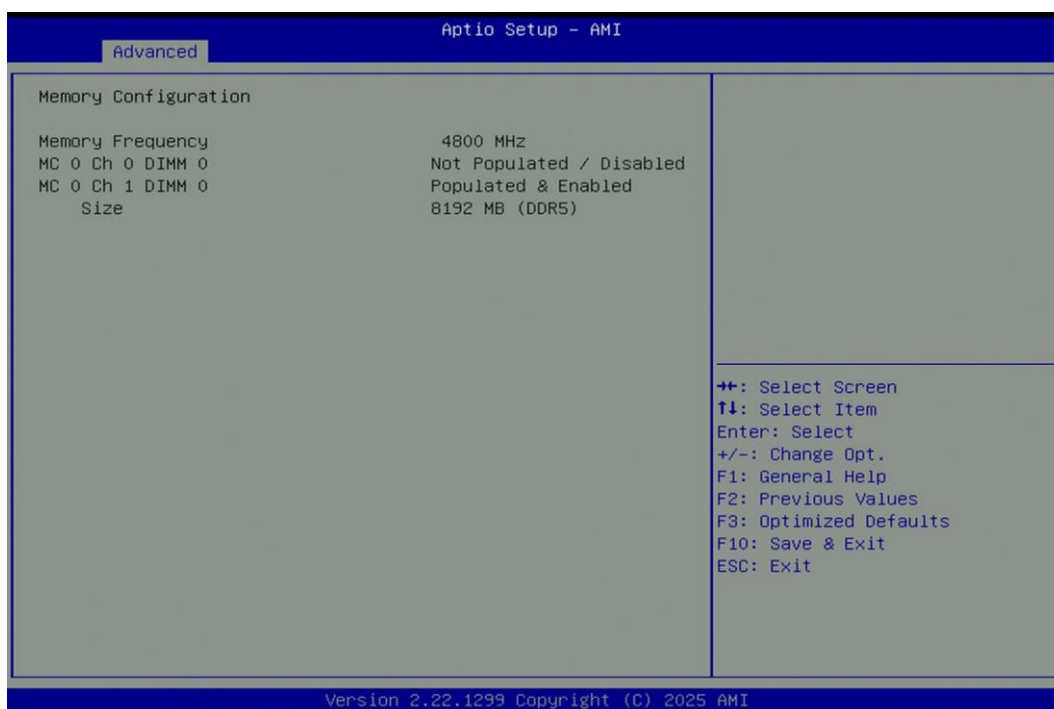

■ Graphics Configuration



❑ Primary Display [Auto]

Allows users to select which graphics device should be the primary display.

Configuration options: [Auto] [IGFX]

❑ Internal Graphics [Auto]

This item allows users to enable or disable Internal Graphics.

Configuration options: [Auto] [Disabled] [Enabled]

■ VMD setup menu



❑ Enable VMD controller [Disabled]

Allows users to enable or disable the VMD Controller.

Configuration options: [Disabled] [Enabled]

Enabling this function allows the system to support RAID and enables the Intel® Rapid Storage Technology (RST) sub-menu.

■ VT-d setup menu

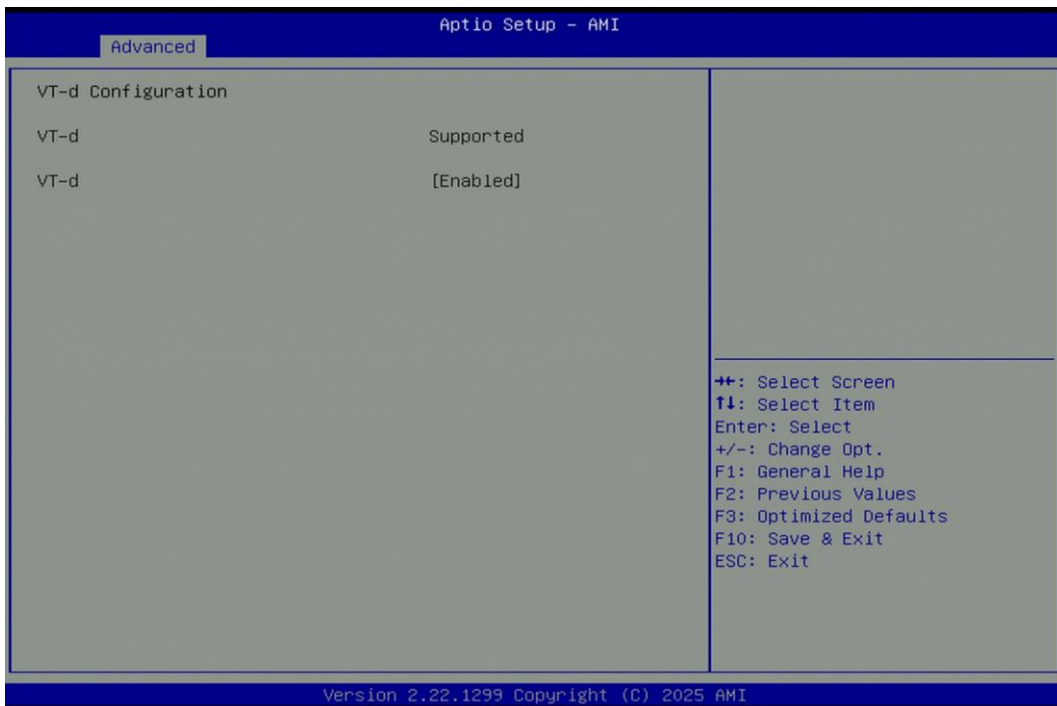

❑ VT-d [Enabled]

This item allows users to enable Intel® Virtualization Technology for Directed I/O (VT-d) function.

4.3.4 PCIE Configuration



PCI Express Root Port (CN7)

PCI Express Root Port [Enabled]

Allows you to enable or disable the PCI Express Port.

PCIe Speed [Auto]

Allows you to select PCI Express interface speed.

Configuration options: [Auto] [Gen1] [Gen2] [Gen3].

PCI Express Root Port (CN6)

PCI Express Root Port [Enabled]

Allows you to enable or disable the PCI Express Port.

PCIe Speed [Auto]

Allows you to select PCI Express interface speed.

Configuration options: [Auto] [Gen1] [Gen2] [Gen3] [Gen4].

PCI Express Root Port (CN5)

PCI Express Root Port [Enabled]

Allows you to enable or disable the PCI Express Port.

PCIe Speed [Auto]

Allows you to select PCI Express interface speed.

Configuration options: [Auto] [Gen1] [Gen2] [Gen3].

4.3.5 PCH-IO Configuration

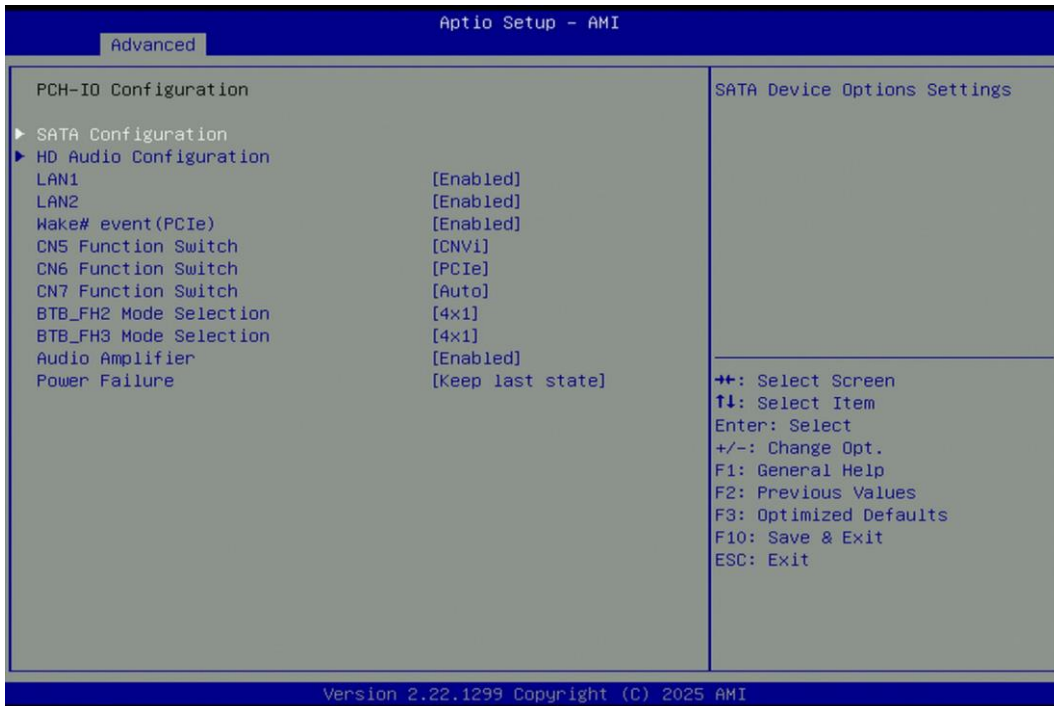

■ SATA Configuration

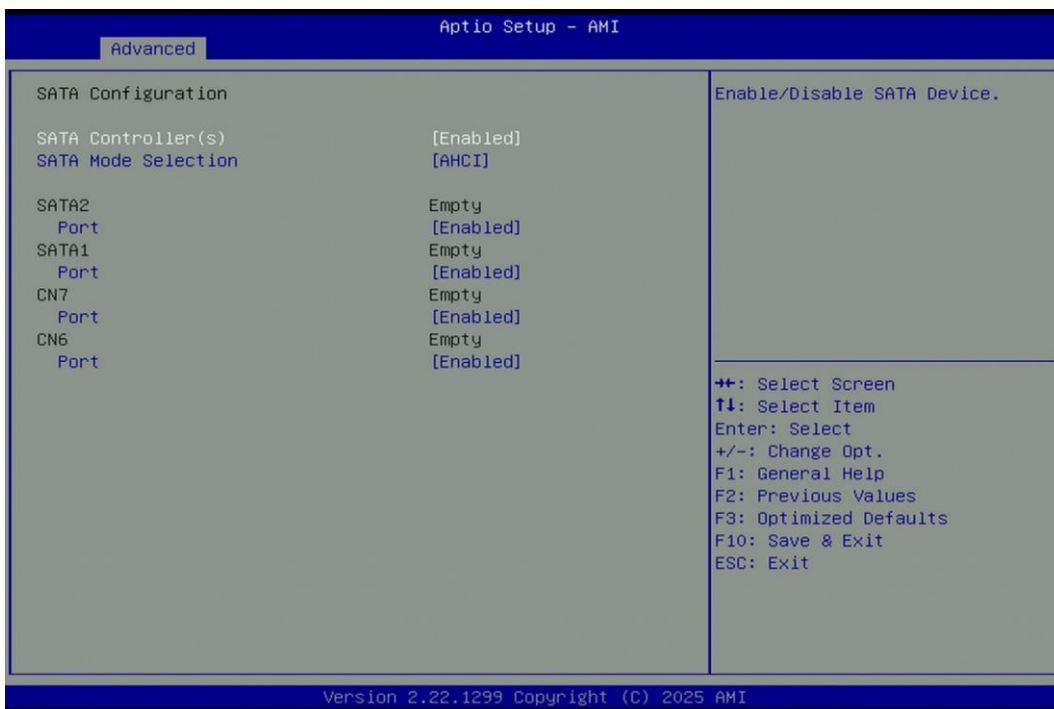

■ SATA Controller(s) [Enabled]

Enables or disables Serial ATA controller.

■ SATA Mode Selection [AHCI]

This item only allows users to choose [AHCI] mode.

SATA2

Port [Enabled]

Enables or disables SATA2.

- SATA1**
Port [Enabled]
Enables or disables SATA1.
- CN7**
Port [Enabled]
Enables or disables CN7.
- CN6**
Port [Enabled]
Enables or disables CN6.

■ HD Audio Configuration

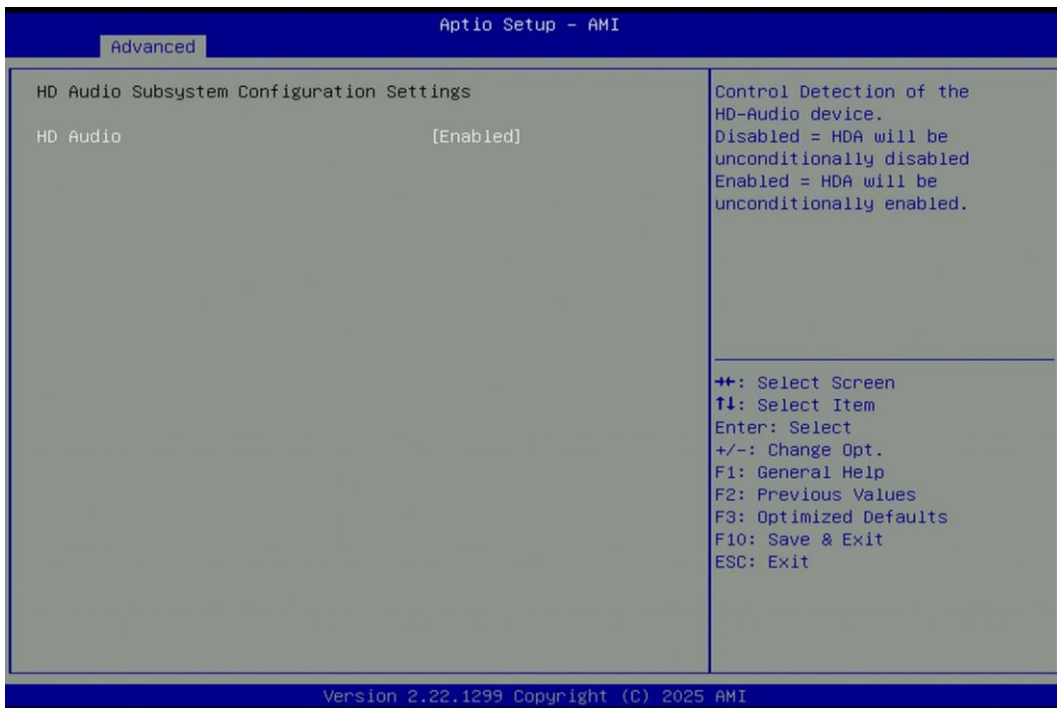

- HD Audio [Enabled]**
Allows you to select HD Audio options.
[Enabled]: HD Audio device is unconditionally enabled.
[Disabled]: HD Audio device is unconditionally disabled.

■ LAN1 [Enabled]

Enables or disables LAN 1.

■ LAN2 [Enabled]

Enables or disables LAN 2.

■ Wake# event (PCIe) [Enabled]

Enables or disables integrated LAN Wake on LAN function.

■ CN5 Function Switch [CNVi]

Allows users to select [CNVi] or [WiFi] for the CN5 connector.

■ CN6 Function Switch [PCIe]

Allows users to select [PCIe] or [SATA] for the CN6 connector.

■ CN7 Function Switch [Auto]

Allows users to select [Auto], [SSD-SATA], [SSD-PCIe], [WWAN-PCIe], or [WWAN-USB3] for the CN7 connector.

■ **BTB_FH2 Mode Selection [4x1]**

Allows users to select [4x1] or [1x4] mode for BTB_FH2.

■ **BTB_FH3 Mode Selection [4x1]**

Allows users to select [4x1] or [1x4] mode for BTB_FH3.

■ **Audio Amplifier [Enabled]**

Enables or disables Audio Amplifier Function.

■ **Power Failure [Keep last state]**

Allows you to specify which power state the system will enter when power is resumed after a power failure (G3 state).

[Always on]: Enters power on state.

[Always off]: Enters power off state.

[Keep last state]: Enters the last power state before a power failure.

4.3.6 PCH-FW Configuration

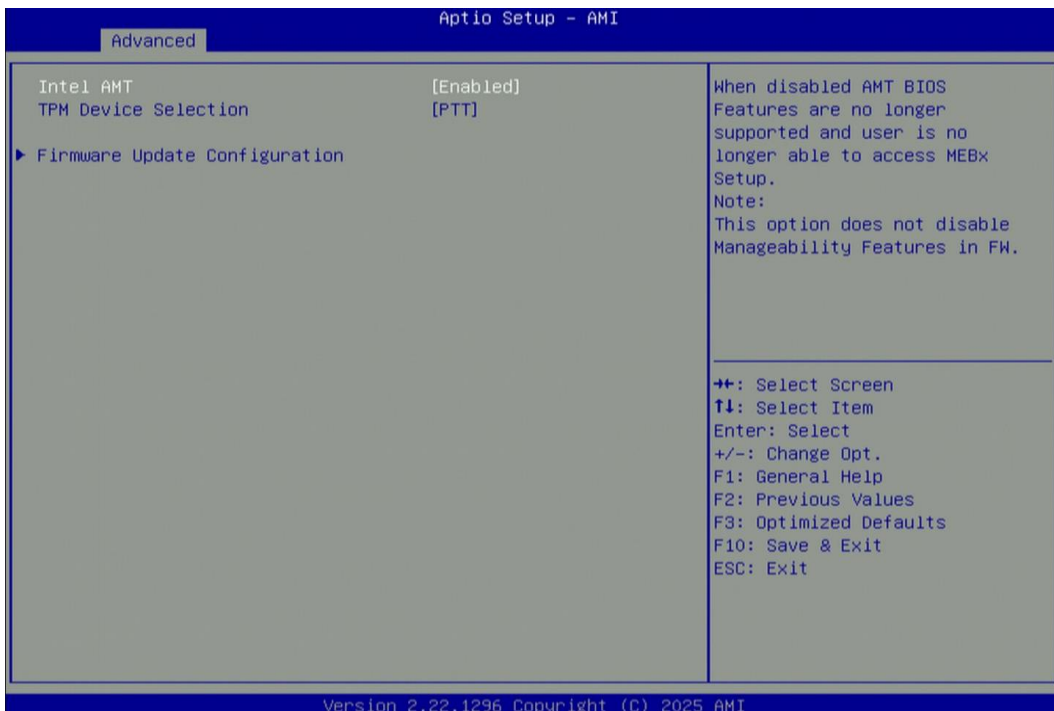

■ **Intel AMT [Enabled]**

Allows users to enable or disable Intel® Active Management Technology BIOS execution.

■ **TPM Device Selection [PTT]**

Allows users to select [PTT] or [dTPM] for TPM Device.

■ Firmware Update Configuration

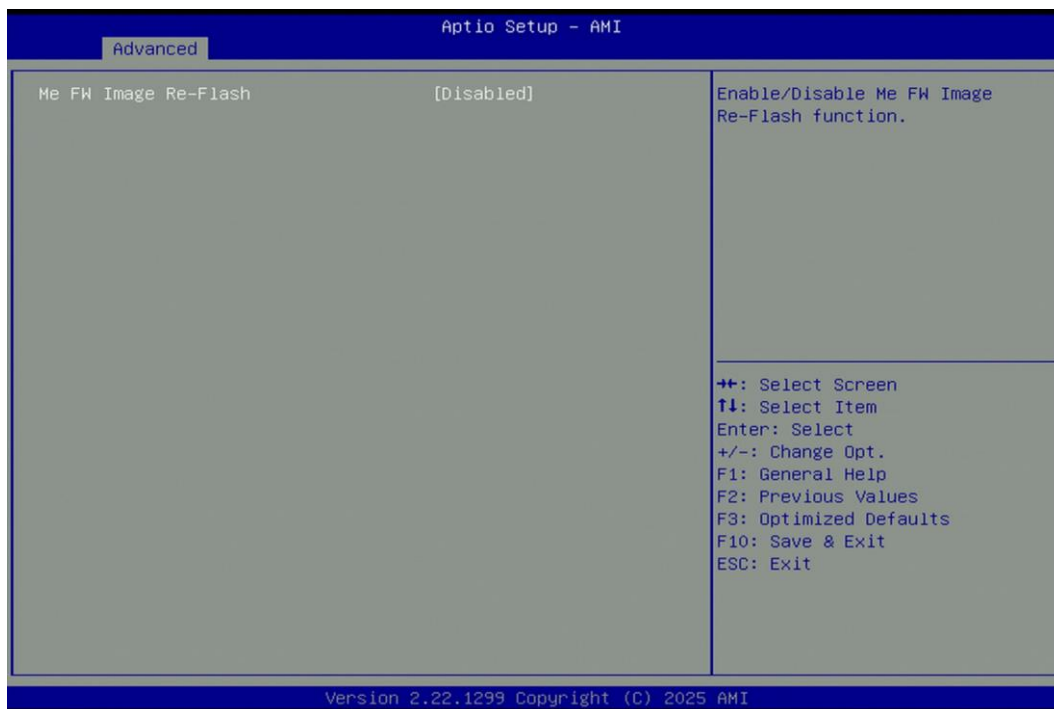

❑ ME FW Image Re-Flash [Disabled]

Allows users to enable or disable the ME firmware image re-flash function.

4.3.7 Trusted Computing

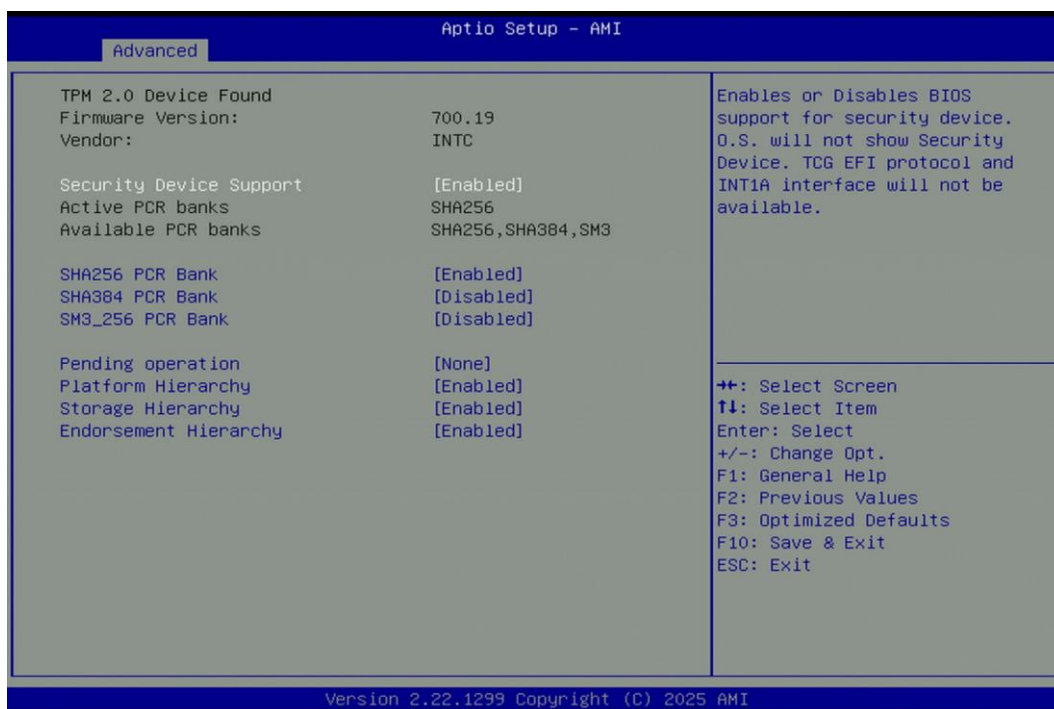

■ Security Device Support [Enable]

Allow users to enable or disable Security Device Support function.

■ SHA256 PCR Bank [Enabled]

Enables or disables SHA256 PCR Bank function.

■ SHA384 PCR Bank [Disabled]

Enables or disables SHA384 PCR Bank function.

■ **SHA3_256 PCR Bank [Disabled]**

Enables or disables SHA3_256 PCR Bank function.

■ **Pending Operation [None]**

Allows users to select which mode Pending Operation will operate.

Configuration options: [None] [TPM Clear]

■ **Platform Hierarchy [Enabled]**

Enables or disables Platform Hierarchy function.

■ **Storage Hierarchy [Enabled]**

Enables or disables Storage Hierarchy function.

■ **Endorsement Hierarchy [Enabled]**

Enables or disables Endorsement Hierarchy function.

4.3.8 ACPI Settings

This item allows users to configure ACPI settings.

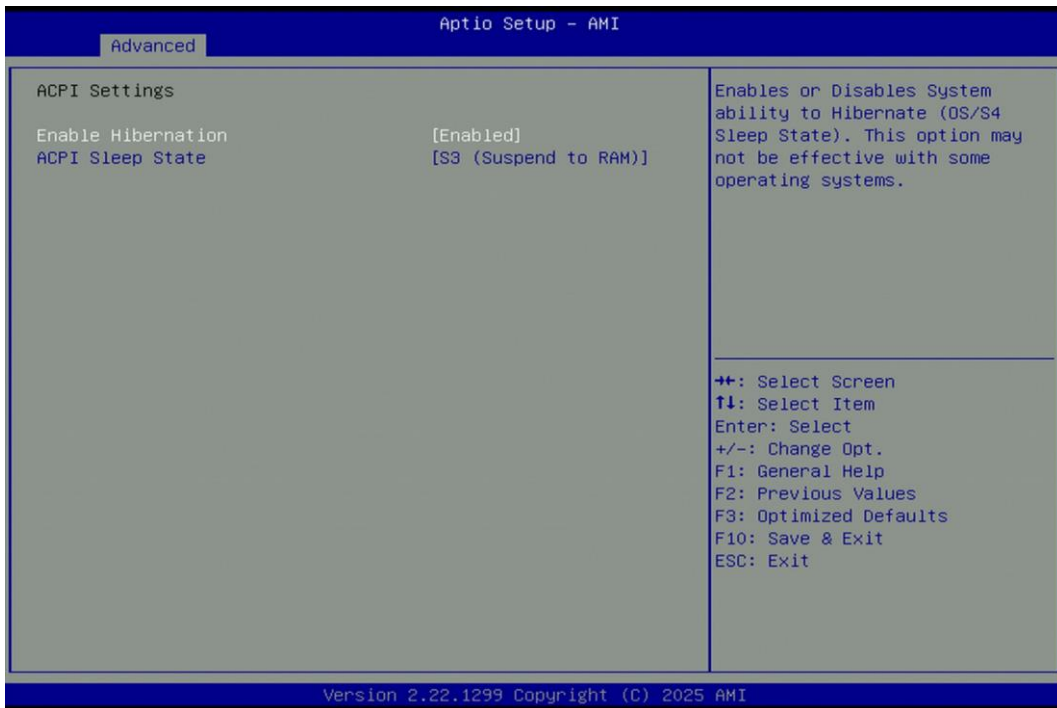

■ **Enable Hibernation [Enabled]**

Enables or disables system hibernation (OS S4 sleep state).

■ **ACPI Sleep State [S3 (Suspend to RAM)]**

Allows users to select the highest Advanced Configuration Power Interface® (ACPI) sleep state that the system will enter when the suspend button is pressed.

[Suspend Disabled]: Disables entering suspend state.

[S3 (suspend to RAM)]: Enables suspend to RAM state.

4.3.9 F81966 Super IO Configuration

The screen allows users to select options for the Super IO configuration and change the value of selected options.

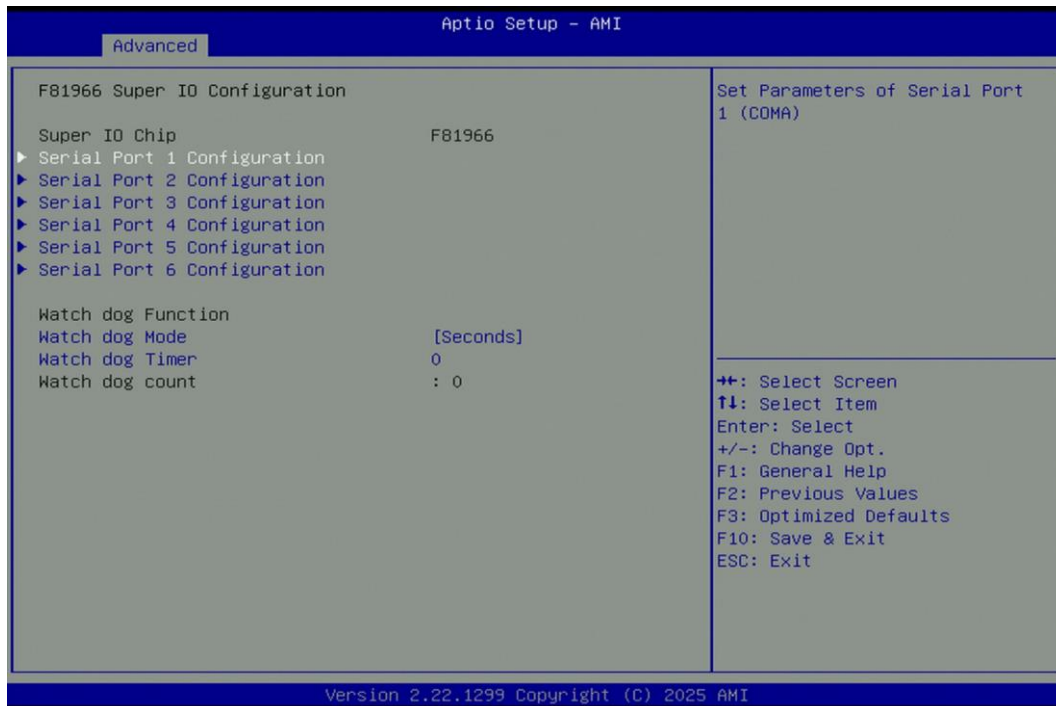

Serial Port 1~6 Configuration

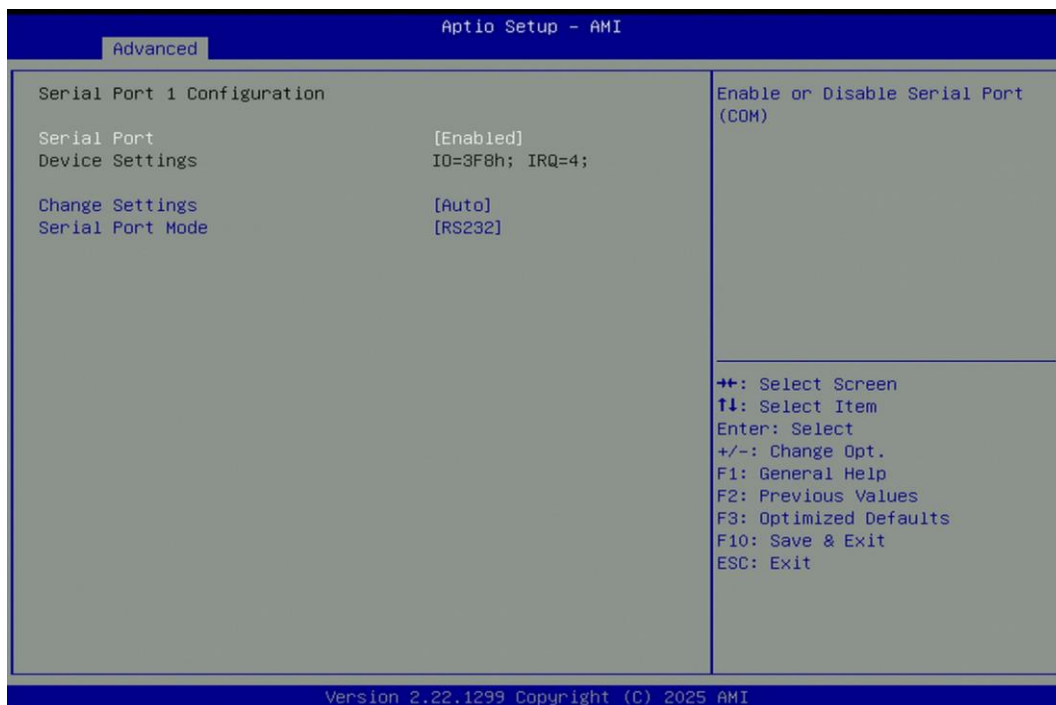

- Serial Port [Enabled]**
This item allows users to enable or disable the serial port.
- Change Settings [Auto]**
This item allows users to change the address & IRQ settings of the specified serial port.

❑ **Serial Port Mode [RS232]**

This item allows users to select Serial Port Mode.

Configuration options: [RS232] [RS422/RS485 Full Duplex] [RS485 Half Duplex]

■ **Watch Dog [Disabled]**

Enables or disables Watch dog function.

■ **Watch Dog Mode [Sec]**

Changes the Watch dog mode. Select [Sec] or [Min].

■ **Watch Dog Timer [0]**

The user can set a value in the range of 0 to 255.

4.3.10 Hardware Monitor

These items display the current status of all monitored hardware devices/ components, such as voltages and temperatures.

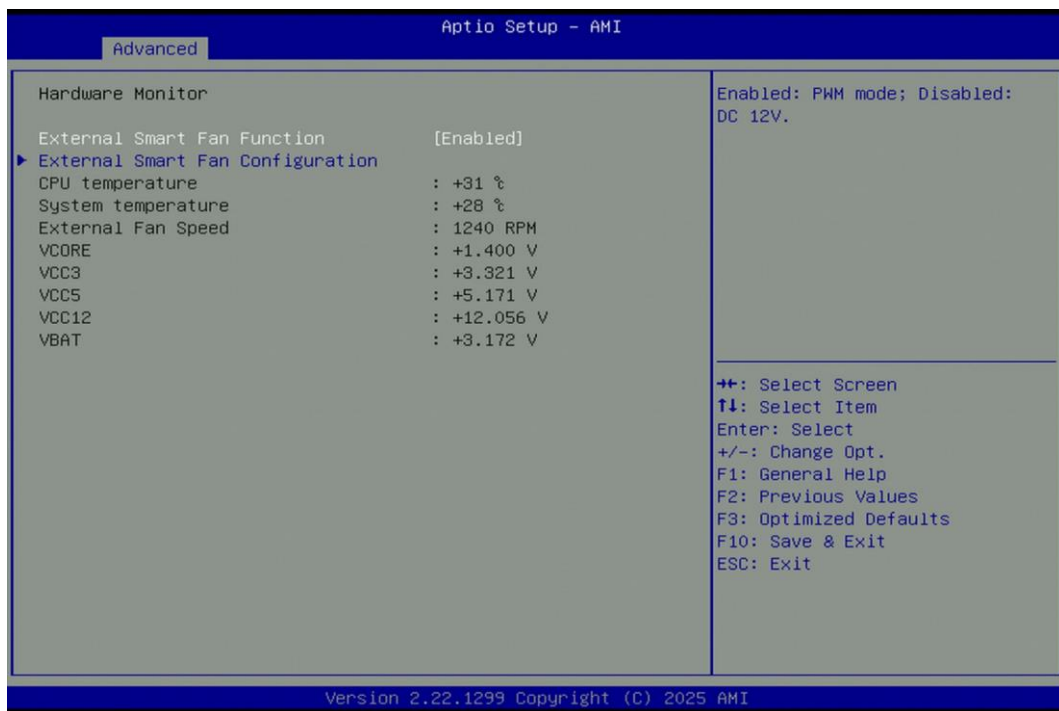

■ **External Smart Fan Function [Enabled]**

Enables or disables external smart fan function.

■ **External Smart Fan Configuration**

Allows users to set external smart fan parameters.

4.3.11 S5 RTC Wake Settings



■ Wake System from S5 [Disabled]

This item allows users to wake the system from S5 state.

[Fixed Time]: Set a specified time (HH:MM:SS) to wake the system.

[Dynamic Time]: Set a countdown time to wake the system.

4.3.12 Serial Port Console Redirection

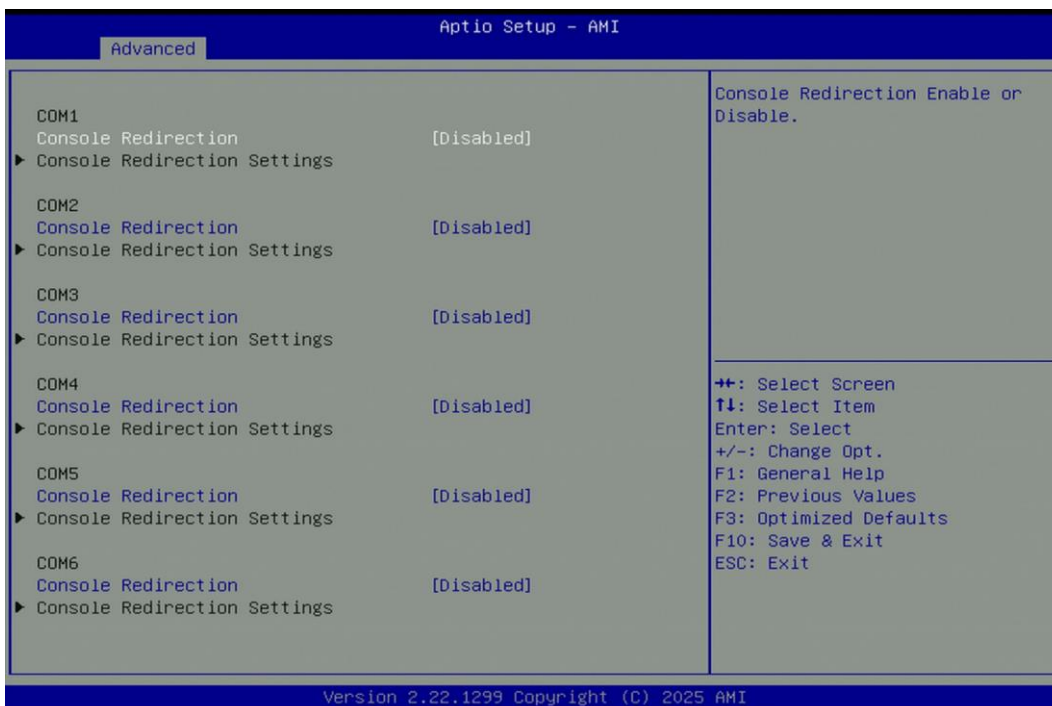

■ Console Redirection [Disabled]

These items allow users to enable or disable COM1, COM2, COM3, COM4, COM5, COM6 console redirection.

4.3.13 USB Configuration



■ XHCI Hand-off [Enabled]

This item allows users to enable or disable XHCI (USB3.2) hand-off function.

■ USB Mass Storage Driver Support [Enabled]

Enables or disables support for USB mass storage devices.

4.3.14 Network Stack Configuration

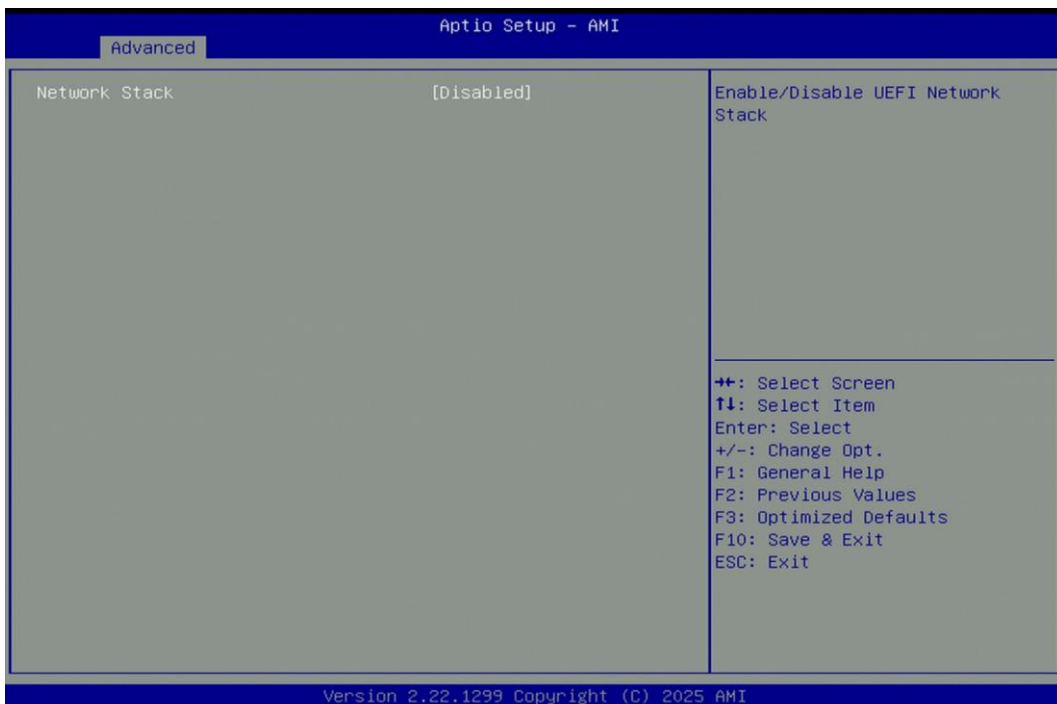

■ Network Stack [Disabled]

Enables or disables UEFI Network Stack.

4.3.15 NVMe Configuration

The screen allows users to select options for the NVMe configuration and change the value of the selected option. These settings appear only if an NVMe Device is detected.



4.4 Security Setup

This section allows users to configure BIOS security settings. To remove a password, select the password, then leave the field blank and press <Enter>.

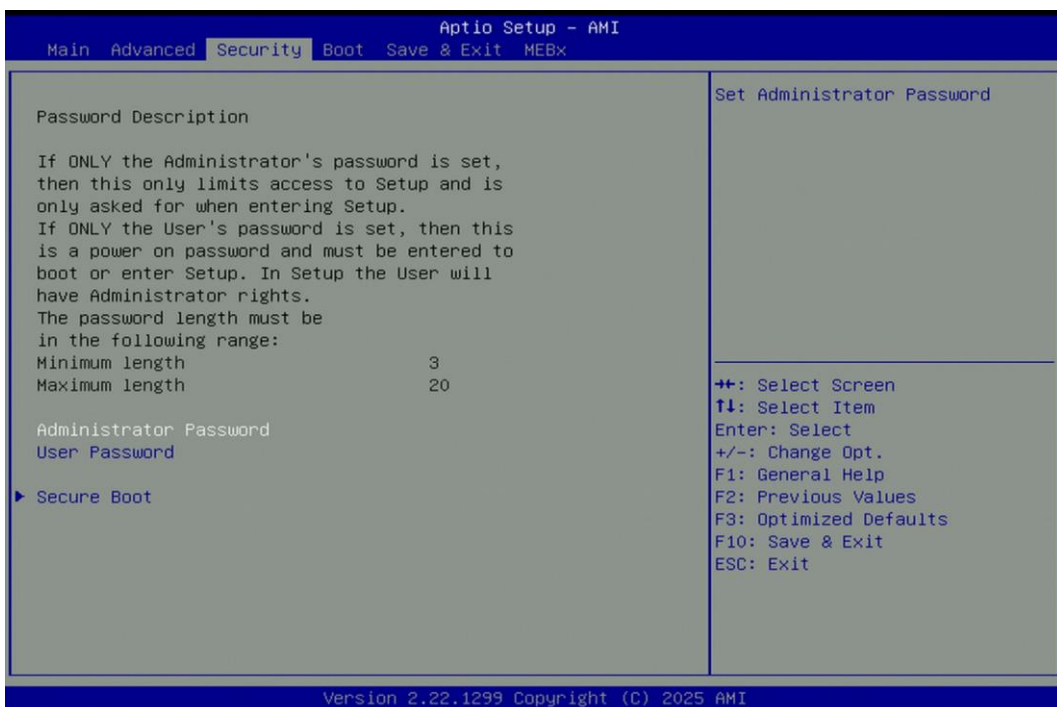

■ Administrator Password

Administrator Password controls access to the BIOS Setup utility.

■ User Password

User Password controls access to the system at boot and to the BIOS Setup utility.

■ Secure Boot



Secure Boot [Disabled]

Enable or disable Secure Boot function.

Secure Boot Mode [Standard]

Allows you to select Secure Boot Mode.

Configuration options: [Standard] [Custom].

4.5 Boot Setup

This section allows you to configure Boot settings.

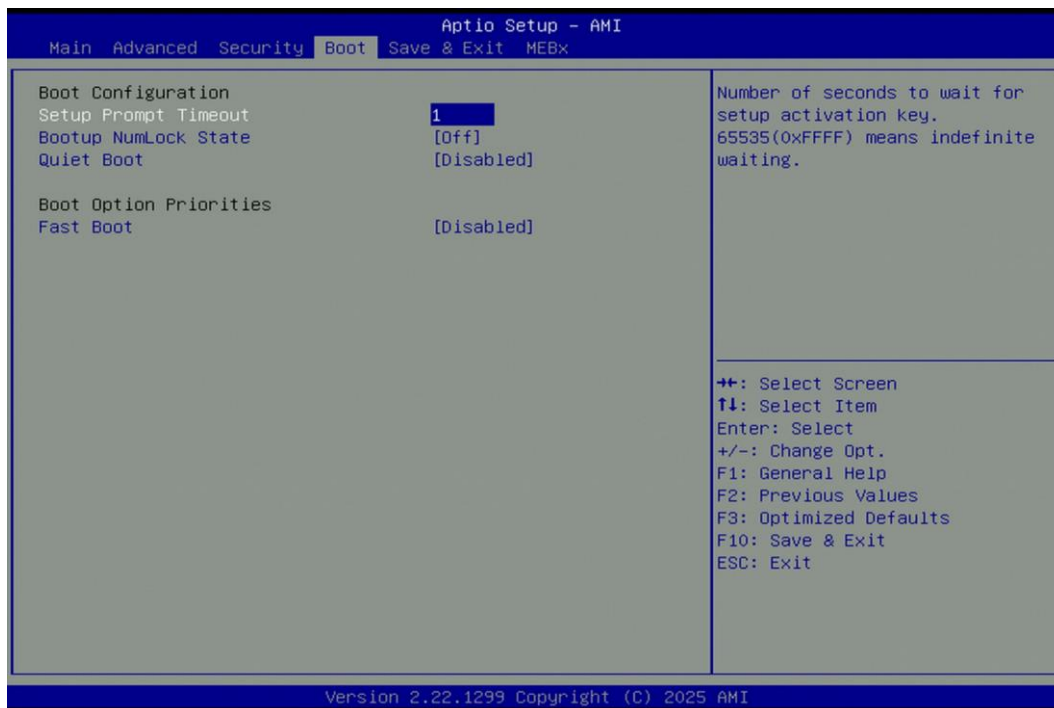

■ Setup Prompt Timeout [1]

Use this item to set the number of seconds (1 to 65535) to wait for setup activation key.

■ Bootup NumLock State [Off]

Allows users to select the power-on state for keyboard NumLock.

■ Quiet Boot [Disabled]

Allows users to enable or disable Quiet Boot.

■ Fast Boot [Disabled]

Allows users to enable or disable Fast Boot.

4.6 Save & Exit

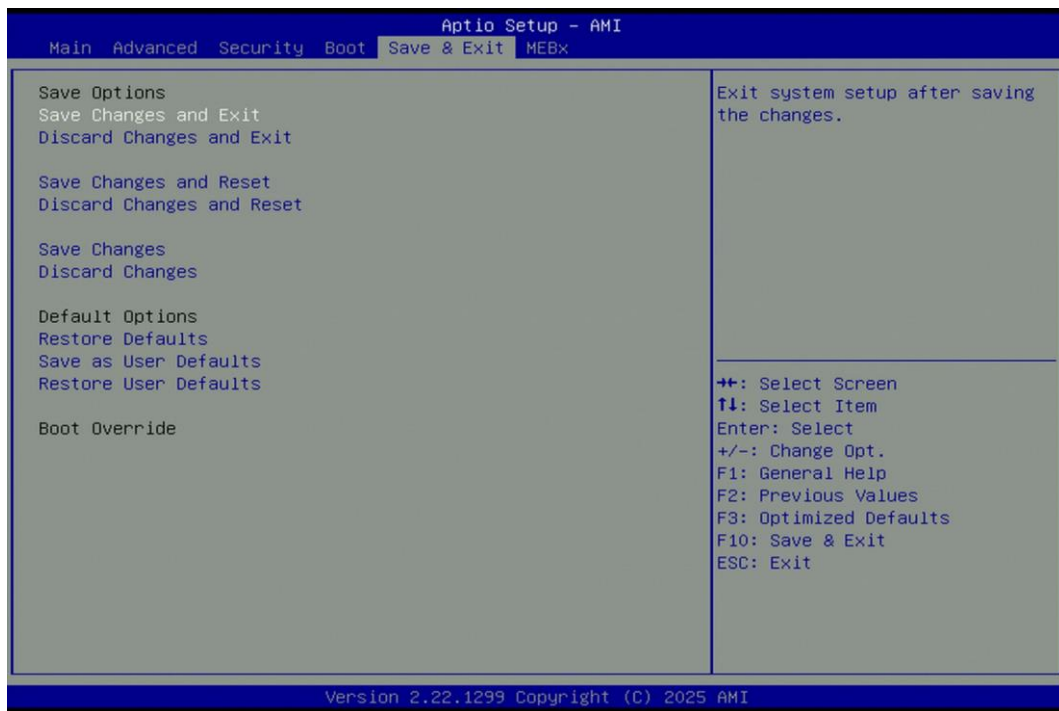

■ Save Changes and Exit

This item allows users to exit system setup after saving changes.

■ Discard Changes and Exit

This item allows users to exit system setup without saving changes.

■ Save Changes and Reset

This item allows users to reset the system after saving changes.

■ Discard Changes and Reset

This item allows users to reset system setup without saving any changes.

■ Save Changes

This item allows users to save changes done so far to any of the setup options.

■ Discard Changes

This item allows users to discard changes done so far to any of the setup options.

■ Restore Defaults

This item allows users to restore/ load default values for all the options.

■ Save as User Defaults

This item allows users to save the changes done so far as user defaults.

■ Restore User Defaults

This item allows users to restore the user defaults to all the options.

4.7 MEBx

This page is for ME function setting. Press the key to enter the BIOS menu, then use the arrow keys to navigate to the MEBx page.

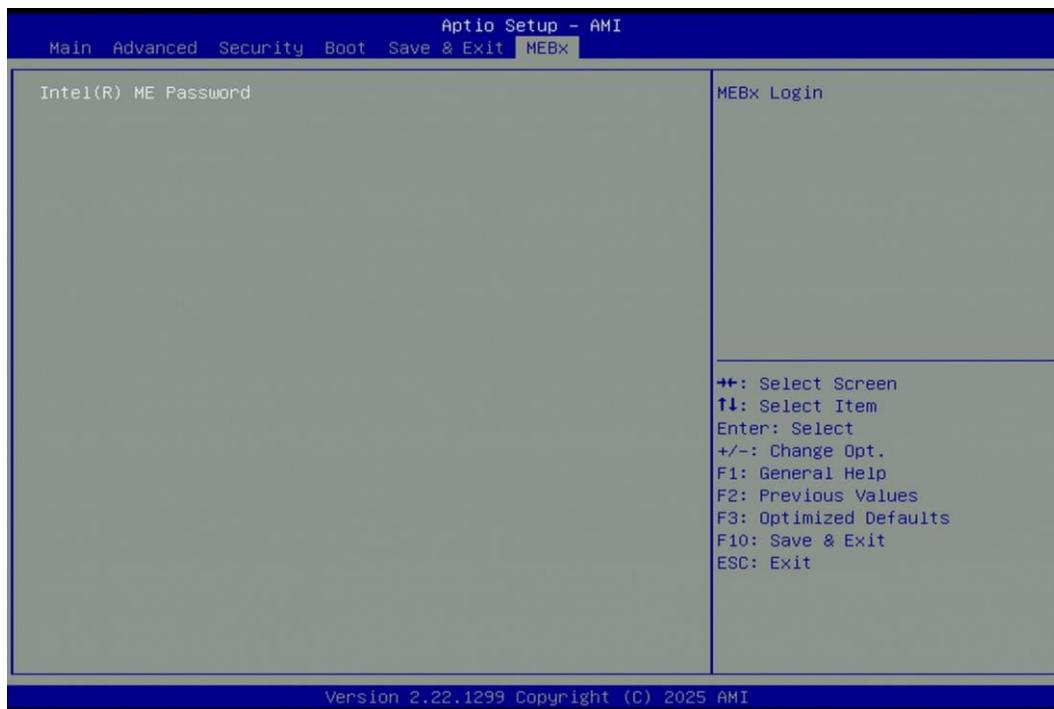

Press <enter> to enter the default password "admin".

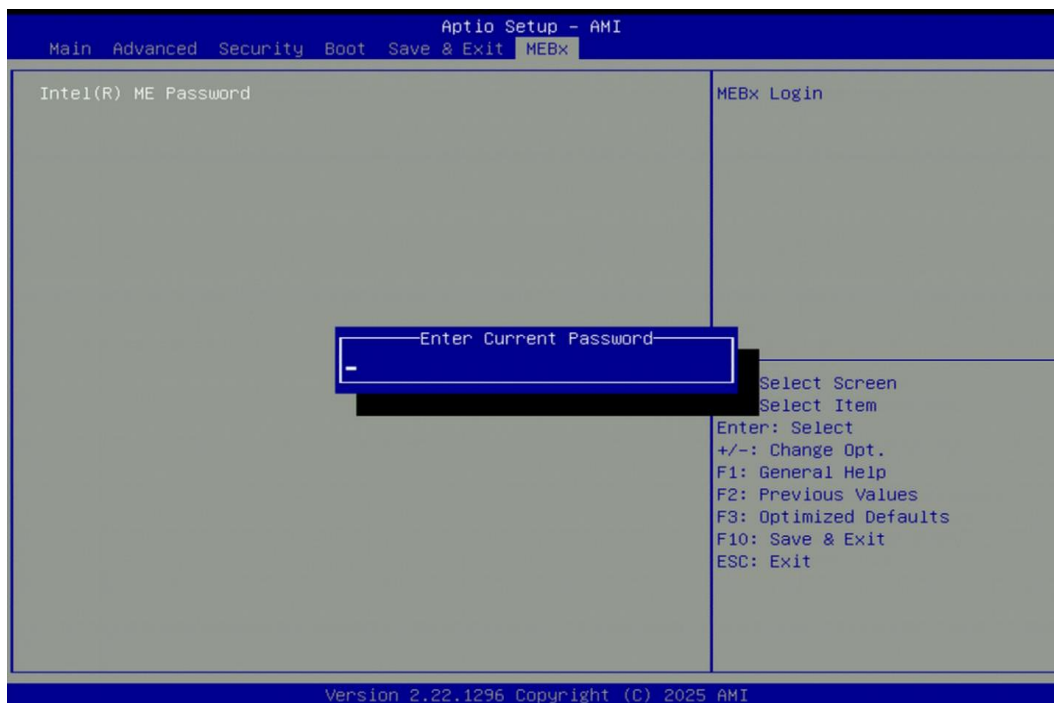

Create a new password using 8 characters including uppercase and lowercase letters, numbers, and special symbols.

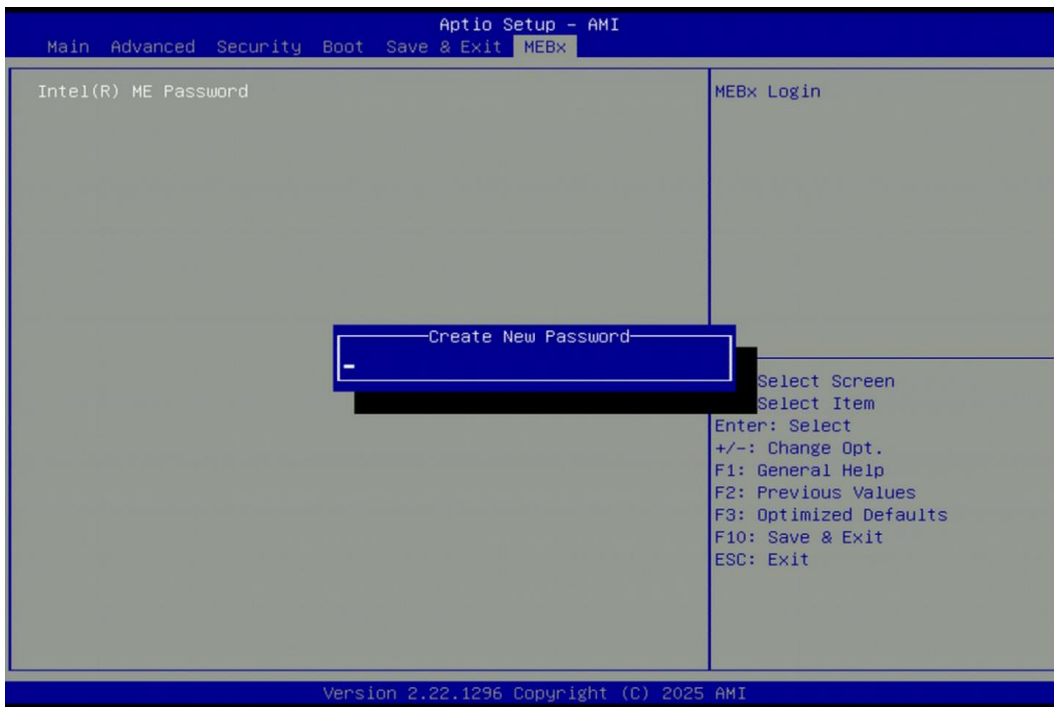

Enter the password again.

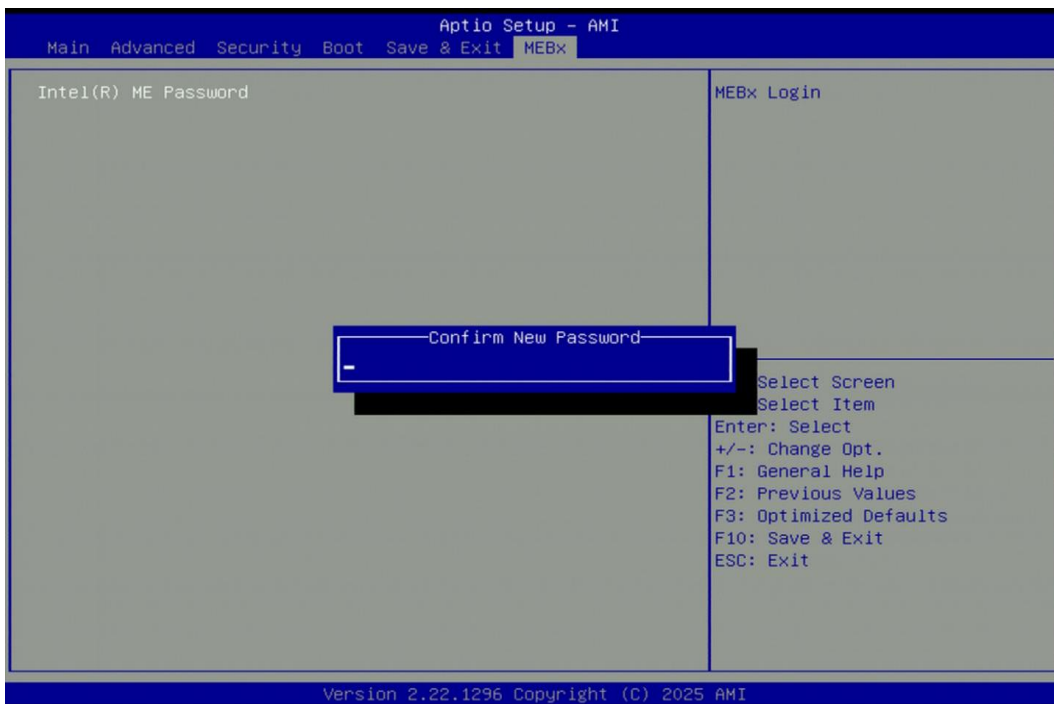

This reveals the MEBx function settings.

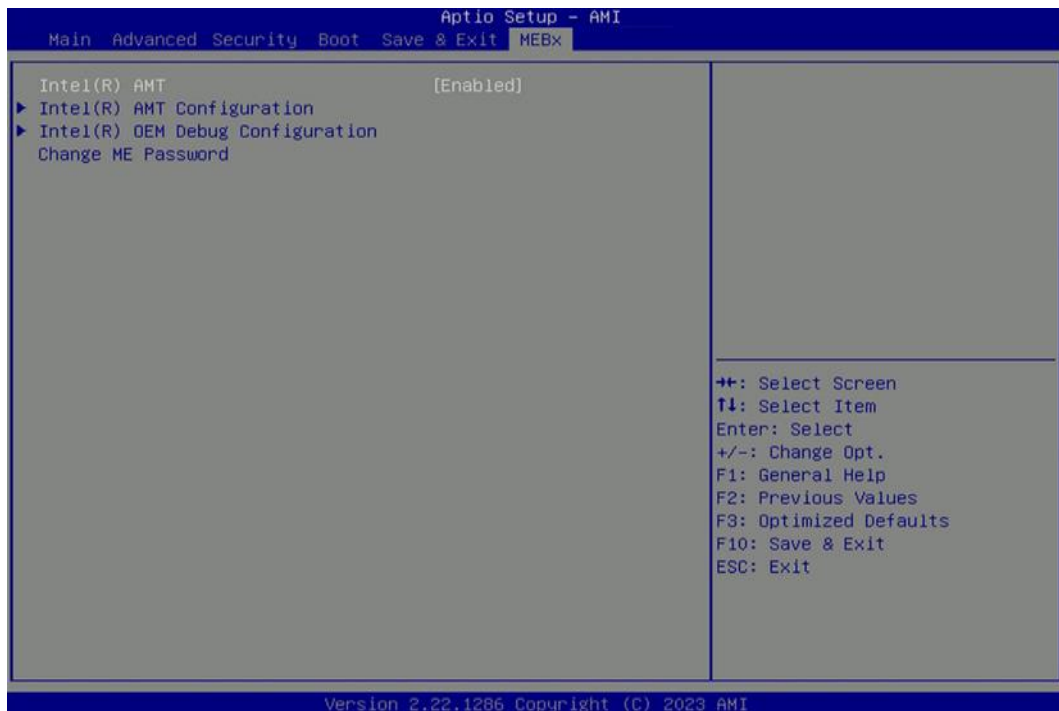



Chapter 5

Product Application

5.1 Where can I download drivers?

Drivers for the DX-1300 Series can be downloaded from the CINCOZE website.

5.2 Where can I find technical documents?

The following documents are the most relevant technical references for the DX-1300 Series. All documents can be accessed via the CINCOZE Partner Zone:

- **Application Notes:** Navigate to *Home > Partner Zone > Technical Support > Application Notes*.
- **Configure & Installation:** Navigate to *Home > Partner Zone > Technical Support > Configure & Installation*.
- **Other Product Information:** Navigate to *Home > Partner Zone > Product Center > Product Information > Rugged Embedded Computers > High Performance & Compact (DX Series) > DX-1300 Series*.

Catalog	Document Title
Application Notes	DIO Application Guide
	DIO Technical Guide
	Instant Reboot Application Guide
	WDT Application Guide
	WDT Technical Guide
Configure & Installation	AT ATX Function Manual
	BIOS Administrator User Password Function Manual
	Clear CMOS Function Manual
	COM Function Manual
	CSM Function Manual
	Digital I/O Function Manual
	How to import Secure Boot Key?
	How to restore Windows image with Clonezilla?
	How to set TPM function under Windows?
	How to stop automatic driver update in Windows SOP
	How to Update BIOS and ME under UEFI shell?
	How to Update BIOS under UEFI shell?
	How to Update BIOS under Windows?
	IGN Module User Manual
	Intel AMT with KVM Remote Control
	POE Module User Manual
	PXE Function Manual
	RAID Function Manual
Remote Switch Function Manual	
Wake On LAN Function Manual	

cincoze

© 2026 Cincoze Co., Ltd. All rights reserved.

The Cincoze logo is a registered trademark of Cincoze Co., Ltd.

All other logos appearing in this catalog are the intellectual property of the respective company, product, or organization associated with the logo.

All product specifications and information are subject to change without notice.