

MXM-A2000

NVIDIA Embedded RTX A2000 MXM Type A, 8G, 60W Kit with Heatsink and Thermal Pad

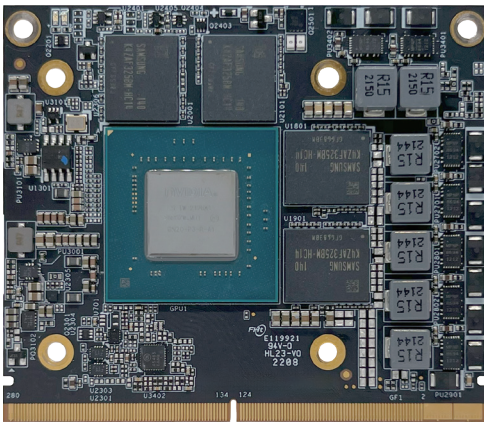

- NVIDIA® RTX™ A2000 Embedded Graphics
- Standard MXM 3.1 Type A Form Factor (82 x 70 mm)
- 2560 NVIDIA® CUDA® Cores, 20 RT cores, and 80 Tensor cores
- 8.25 TFLOPS Peak FP32 Performance
- PCIe Gen 4 x8 interface
- 5-year Availability

Specifications

GPU	▪ NVIDIA RTX™ A2000 GA107-980 GPU
Memory	▪ 8GB GDDR6 memory, 128-bit (Bandwidth: 192 GB/s)
CUDA Cores	▪ 2560 CUDA cores, 8.25 TFLOPS peak FP32 performance
Tensor Cores	▪ 80 Tensor Cores
RT Cores	▪ 20 RT Cores
Compute API	▪ CUDA Compute 8.0 and above, OpenCL™ 1.2
Graphics API	▪ DirectX® 12, OpenGL 4.6
Display Outputs	▪ 4x DisplayPort 1.4 digital video outputs, 4K at 120Hz or 8K at 60Hz
Interface	▪ MXM 3.1, PCI Express Gen4 x8 support
Dimensions	▪ 82 (W) x 70 (D) x 4.8 (H) mm
Form Factor	▪ Standard MXM 3.1 Type A
Power Consumption	▪ 60W
OS Support	▪ Windows 10 & Linux support by project

Dimensions

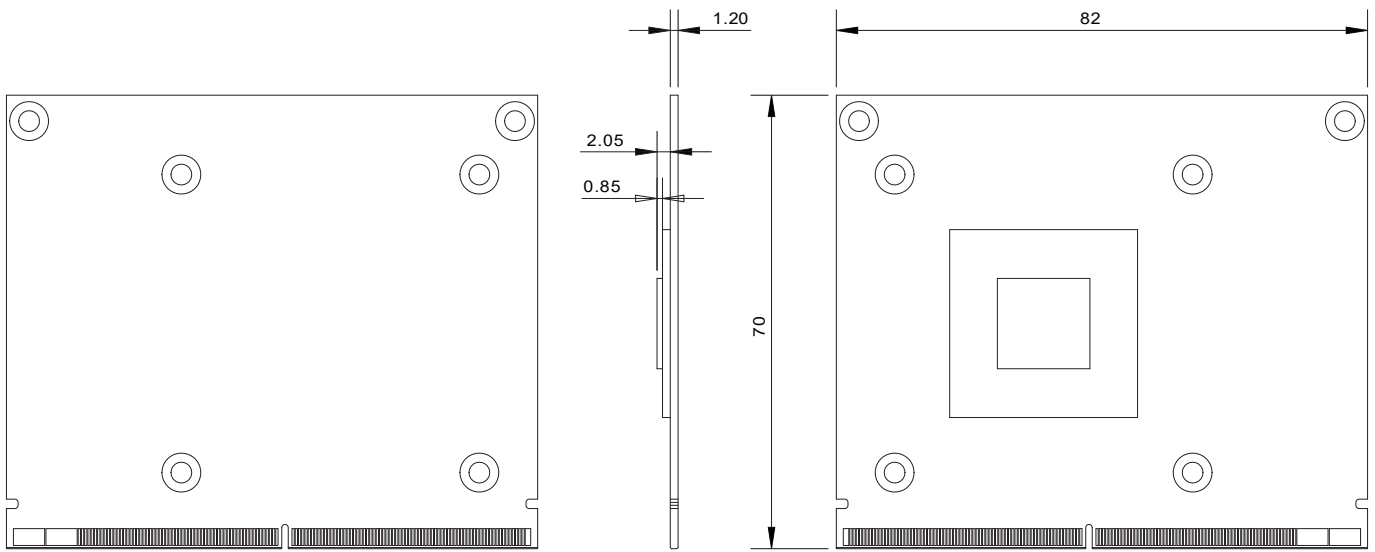

Unit: mm

Ordering Information

Available Models

Model No.	Description
MXM-A2000-R10	NVIDIA Embedded RTX A2000 MXM Type A, 8G, 60W Kit with Heatsink and Thermal Pad

Package Checklist

• NVIDIA RTX™ Embedded A2000 GPU Card x 1	• GPU Heatsink x 1
• GPU Thermal Pad Kit x 1	• Screw Pack x 1